



WORK-RATED[®]

THE NEW CENTURY SERIES[®]

Wire Rope Electric Hoists

Product Series 34

Parts Manual

SERIAL NUMBER

WARNING

This equipment should not be installed, operated or maintained by any person who has not read all the contents of Instruction, Operation, and Maintenance Manual 69833; and Parts Manual 69836. Failure to read and comply with the instructions or any one of the limitations noted in either manual can result in serious bodily injury or death, and/or property damage.

There are no other warranties which extend beyond the description on the Order Acknowledgment and as it may apply to the specifications provided in this publication. THE IMPLIED WARRANTIES OF MERCHANTABILITY AND FITNESS FOR A PARTICULAR PURPOSE ARE EXCLUDED. Acco Material Solutions/Harrington Hoists Inc. shall in no event be liable for any special, direct, indirect, incidental or consequential damages to anyone beyond the cost of replacement of the goods sold hereby.



TABLE OF CONTENTS

NOTICE

Parts Manual 69836 covers parts information in reference to Product Series 34 of the WRIGHT™ WORK-RATED™ THE NEW CENTURY SERIES™ wire rope electric hoist line. This manual includes parts information for a variety of hoist types. Therefore, all parts information may not apply to any one type or size of specific hoist. Disregard those portions of the manual that do not apply. Parts Manual 69836 should be used in conjunction with Manual 69833: Installation, Operation, and Maintenance Manual for WRIGHT™ WORK-RATED™ THE NEW CENTURY SERIES™ Wire Rope Electric Hoists. Refer to Manual 69833 for instructions on installation, operation, inspection, testing, adjusting, and maintaining this equipment; and Parts Manual 69836 for parts information and identification. Use of the term MANUAL refers to both Manual 69833 and Parts Manual 69836.

SUBJECT	PAGE
IMPORTANT INFORMATION AND WARNINGS.....	3
HOIST MOTOR BRAKE ASSEMBLY	5
HOIST GEAR HOUSING ASSEMBLY.....	6
HOIST MOTOR.....	8
SUSPENSION - 2PS REEVING	9
SUSPENSION - 4PS REEVING	10
SUSPENSION - 2PD REEVING	11
SUSPENSION - 4PD REEVING	12
LOAD BLOCK - 2PS REEVING	13
LOAD BLOCK - 4PS REEVING	14
LOAD BLOCK - 2PD REEVING	15
LOAD BLOCK - 4PD REEVING	16
GRAVITY LIMIT SWITCH	17
GEARED LIMIT SWITCH.....	18
HOIST RECTIFIED D.C. BRAKE CONTROL.....	19
BASIC CONTROL COMPONENTS.....	20
PENDANT CONTROL STATION.....	23
2-WHEEL PLAIN TROLLEY - 6 IN. DIA. WHEEL.....	25
4-WHEEL PLAIN TROLLEY - 6 IN. DIA. WHEEL.....	26
4-WHEEL GEARED TROLLEY - 6 IN. DIA. WHEEL.....	27
4-WHEEL GEARED TROLLEY - DUAL DRIVE - 6 IN. DIA. WHEEL.....	28
LOAD BAR ASSEMBLY FOR RIGID TROLLEYS.....	29
HAND-GEARED TROLLEY DRIVE.....	30
MOTORIZED TROLLEY DRIVE.....	32
MOTORIZED TROLLEY RIGHT-ANGLE REDUCER.....	33
TROLLEY MOTOR BRAKE ASSEMBLY	34
DECK MOUNTED FRAME	35
WINCH UNIT FRAME	35
TOP-RUNNING TROLLEY	36
LOAD BAR ASSEMBLY FOR SWIVELING TROLLEYS.....	37
OPTIONAL ELECTRICAL CONTROL ENCLOSURE	38

NOTICE

TO ORDER PARTS: Provide part number, part description, quantity required, and Product Number or Serial Number of Hoist.

IMPORTANT INFORMATION AND WARNINGS

SAFETY ALERT SYMBOL

The Safety Alert Symbol is used in this manual to indicate hazards and to alert the reader to information that should be known, understood, and followed in order to avoid DEATH or SERIOUS INJURY.

Read and understand this manual before using the hoist.

Important issues to remember during operation are provided at the hoist control stations, at various locations on the hoist and in the manuals by **DANGER**, **WARNING**, or **CAUTION** instructions or placards, that alert the personnel to potential hazards, proper operation, load limitations, and more.

 **DANGER** Indicates an imminently hazardous situation which, if not avoided, will result in death or serious injury.

 **WARNING** Indicates a potentially hazardous situation which, if not avoided, could result in death or serious injury.

 **CAUTION** Indicates a potentially hazardous situation which, if not avoided, may result in minor or moderate injury. It may also be used to alert against unsafe practices.

CAUTION

These general instructions deal with the normal installation, operation, and maintenance situations encountered with the equipment described herein. The instructions should not be interpreted to anticipate every possible contingency or to anticipate the final system, crane, or configuration that uses this equipment.

This manual includes instructions and parts information for a variety of hoist types. Therefore, all instructions and parts information may not apply to any one type or size of specific hoist. Disregard those portions of the instructions that do not apply.

Record hoist serial number on the front cover of this manual for identification and future reference to avoid referring to the wrong manual for information or instructions on installation, operation, inspection, maintenance, or parts.

Use only Wright® authorized replacement parts in the service and maintenance of this hoist.

WARNING

Equipment described herein is not designed for and should not be used for lifting, supporting, or transporting humans.

Equipment described herein should not be used in conjunction with other equipment unless necessary and/or required safety devices applicable to the system, crane, or application are installed by the system designer, system manufacturer, crane manufacturer, installer, or user.

Modifications to upgrade, rerate, or otherwise alter this equipment shall be authorized only by the original equipment manufacturer or qualified professional engineer.

Equipment described herein may be used in the design and manufacture of cranes or monorails. Additional equipment or devices may be required for the crane or monorail to comply with applicable crane design and safety standards. The crane designer, crane manufacturer, or user is responsible to furnish these additional items for compliance. Refer to ASME B30.17, Safety Standard for Top-Running Single Girder Cranes; ASME B30.2 Safety Standard for Top-Running Double-Girder Cranes; and ASME B30.11 Safety Standard for Underhung Cranes and Monorails. If a below-the-hook lifting device or sling is used with a hoist, refer to ASME B30.9, Safety Standard for Slings, or ASME B30.20, Safety Standard for Below-the-Hook Lifting Devices.

Hoists and cranes, used to handle hot molten material may require additional equipment or devices. Refer to ANSI Z241.2, Safety Requirements for Melting and Pouring of Metals in the Metalcasting Industry.

Electrical equipment described herein is designed and built in compliance with ACCO/Harrington Chain & Lifting Products interpretation of ANSI/NFPA 70, National Electrical Code. The system designer, system manufacturer, crane designer, crane manufacturer, installer, or user is responsible to assure that the installation and associated wiring of these electrical components is in compliance with ANSI/NFPA 70, and all applicable Federal, State, and Local Codes.

Failure to read and comply with any of the limitations noted herein can result in serious bodily injury or death, and/or property damage.

IMPORTANT INFORMATION AND WARNINGS

DANGER

HAZARDOUS VOLTAGES ARE PRESENT IN THE CONTROL ENCLOSURE, OTHER ELECTRICAL COMPONENTS, AND CONNECTIONS BETWEEN THESE COMPONENTS.

Before performing ANY mechanical or electrical maintenance on the equipment, de-energize (disconnect) the main switch supplying power to the equipment; and lock and tag the main switch in the de-energized position. Refer to ANSI 2244.1, Personnel Protection – Lockout/Tagout of Energy Sources.

Do not operate the equipment without control enclosure cover or covers in place.

Only trained and competent personnel should inspect and repair this equipment.

NOTICE

It is the responsibility of the owner/user to install, inspect, test, maintain, and operate a hoist in accordance with ASME B30.16, Safety Standard for Overhead Hoists, OSHA Regulations, and ANSI/NFPA 70, National Electrical Code. If the hoist is installed as part of a total lifting system, such as an overhead crane or monorail, it is also the responsibility of the owner/user to comply with the applicable ASME B30 volume that addresses that type of equipment.

It is the responsibility of the owner/user to have all personnel that will install, inspect, test, maintain, and operate a hoist read the contents of this manual and applicable portions of ASME B30.16, Safety Standard for Overhead Hoists, OSHA Regulations, and ANSI/NFPA 70, National Electrical Code. If the hoist is installed as part of a total lifting system, such as an overhead crane, the applicable ASME B30 volume that addresses that type of equipment must also be read by all personnel.

Any ANSI Standards referenced in this manual may be obtained from the American National Standards Institute, 1430 Broadway, New York, New York 10018.

This manual contains information for safe operation of an overhead hoist. Taking precedence over any specific rule, however, is the most important rule of all "USE COMMON SENSE." Operation of an overhead hoist involves more than operating the controls. The operator must consider and anticipate the motions and actions that will occur as a result of operating the controls.

If the hoist owner/user requires additional information, or if any information in the manual is not clear, contact ACCO/Harrington or the distributor of the hoist. Do not install, inspect, test, maintain, or operate the hoist unless this information is fully understood.

When contacting ACCO/Harrington or the distributor of the hoist, always make reference to the serial number of the hoist.

A regular schedule of inspection of the hoist in accordance with the requirements of the ASME B30.16 should be established and records maintained.

WARNING

Before installing, removing, inspecting, or performing any maintenance on a hoist, the main switch shall be de-energized. Lock and tag the main switch in the de-energized position in accordance with ANSI 2244.1. Follow other maintenance procedures outlined in this manual and applicable ASME B30 volumes.

Additional WARNINGS are listed in various portions of this manual. Personnel shall read and follow these WARNINGS. Failure to read and comply with these WARNINGS as well as other instructions or any limitations noted in this manual and applicable ASME B30 volumes could result in serious bodily injury or death, and/or property damage.

PARTS LIST - PRODUCT SERIES 34

HOIST MOTOR BRAKE ASSEMBLY

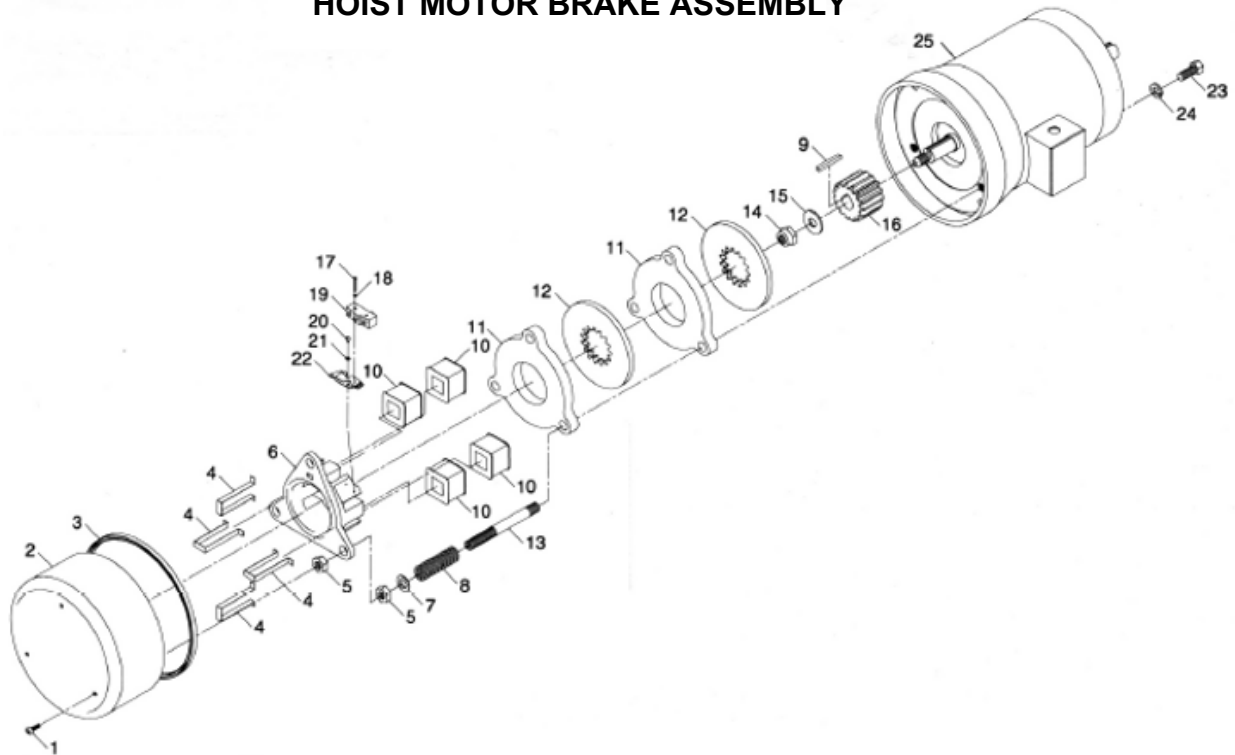

HOIST MOTOR BRAKE PARTS

ITEM NO.	DESCRIPTION	QTY	68 LB FT TORQUE (a)
			PART NO.
1	Screw, LOC-WELL (d)	3*	69757-21 (b) (c) PA7323
2	Cover	1	69743-03
3	Gasket	3.1 ft*	PA7110
4	Coil Strap	4	51451
5	Nut, Jam	6	24-12C
6	Magnet	1	51447
7	Washer	3	PA5183
8	Spring	3	PA6275 (e)
9	Key (g)	1	70879
10	Coil	4	51452
11	Armature Plate	2	51443
12	Lining Disc	2*	51439
13	Stud	3	69991
14	Locknut	1*	PA2434
15	Washer	1	15-10-0
16	Hub	1	69990
17	Screw	2	3-06-14
18	Lockwasher	2	19-06
19	Switch	1	PA6079
20	Screw	2	3-08-4
21	Lockwasher	2	19-08C
22	Mounting Bracket	1	PA6080
23	Bolt	4	(f)
24	Lockwasher	4	(f)
25	Motor	1	(f)

NOTES:

- (a) On standard hoists, 68 lb. ft. torque brakes are used with single-speed and two-speed 15 HP motors.
- (b) Number in heading of chart is Hoist Motor Brake Assembly number.
- (c) This brake is not used on hoists in Hazardous (Classified) locations as identified by the National Electrical Code.
- (d) Screw with self-locking feature must be utilized. Substitutes are not permissible.
- (e) Springs are color coded. Spring (PA6275) for 68 lb. ft. torque brake is yellow in color.
- (f) For part numbers, refer to page 8, Hoist Motor.
- (g) Included with hoist motor. Also available individually.

*Recommended Spare Parts

HOIST GEAR HOUSING ASSEMBLY

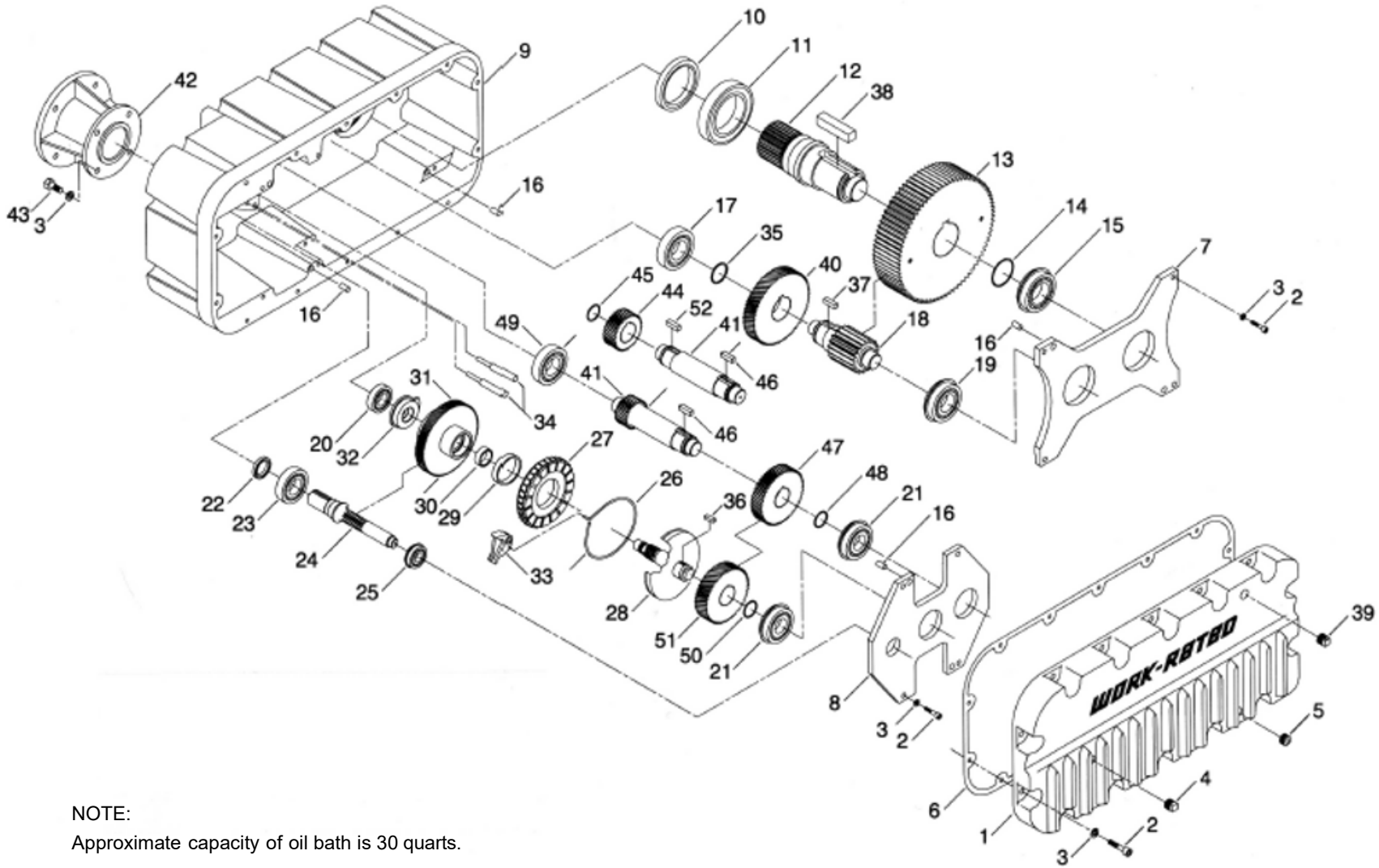

NOTE:
Approximate capacity of oil bath is 30 quarts.

PARTS LIST - PRODUCT SERIES 34

HOIST GEAR HOUSING ASSEMBLY

HOIST GEAR HOUSING PARTS

ITEM NO.	PART NUMBER	DESCRIPTION	QTY/ ASSY
1	70037	Gear Housing Cover	1
2	1-8-24	Bolt, 1/2-13 x 1-1/2	22
3	17-8C	Lockwasher, 1/2	26
4	PA7380	Oil Level Plug	1
5	PA798	Pipe Plug	1
6*	70039	Gasket	1
7	70041	Output Spider	1
8	70040	Input Spider	1
9	70036	Gear Housing	1
10*	PA7441	Oil Seal	1
11	PA7439	Bearing	1
12	70045	Drum Shaft	1
13	70047	Drum Gear	1
14	PA7443	Retaining Ring	1
15	PA7440	Bearing	1
16	PA7394	Dowel Pin	4
17	PA7437	Bearing	1
18	70044	Drum Pinion Shaft	1
19	PA7438	Bearing	1
20	PA6563	Bearing	1
21	PA7436	Bearing	2
22*	PA7442	Oil Seal	1
23	PA7434	Bearing	1
24	70042	Motor Pinion Shaft	1
25	PA7435	Bearing	1
26	54430	Pawl Spring	1

ITEM NO.	PART NUMBER	DESCRIPTION	QTY/ ASSY
27	54343	Ratchet Unit	1
28	55683	Brake Shaft Unit	1
29	PA6289	Needle Bearing, Outer	1
30	PA6290	Needle Bearing, Inner	1
31	55695	Brake Gear	1
32	50564	Check Sleeve	1
33	60799	Pawl	1
34	70131	Pawl Pin	2
35	PA7037	Retaining Ring	1
36	70231	Key	1
37	70057	Key	1
38	70058	Key	1
39	PA7381	Vent Plug	1
40	(a)	Change Gear	(a)
41	(a)	Change Pinion or Shaft	(a)
42	70038	Motor Snout	1
43	35-8-24C	Bolt, 1/2-13 x 1-1/2	4
44	(a)	Change Pinion	(a)
45	(a)	Retaining Ring	(a)
46	70048	Key	1
47	70050	Change Gear	1
48	PA1269	Retaining Ring	1
49	PA6616	Bearing	1
50	PA6144	Retaining Ring	1
51	70049	Change Pinion	1
52	(a)	Key	(a)

NOTE:

(a) Gearing varies with the speed of the hoist. Three gear sets are available, each identified by Gear Housing Assembly No. 70060 with dash number suffix (-01 thru -02). Select proper dash number by counting and comparing number of teeth in gear and pinion.

The parts of this assembly that affect the speed of the hoist are items 40, 41, 44, 45, and 52.

GEAR HOUSING ASSEMBLY			70060-01	70060-02
LIFTING SPEED (2PS/2PD)			30 FPM	44 FPM
LIFTING SPEED (4PS/4PD)			15 FPM	22 FPM
ITEM NO.	PART NO.	DESCRIPTION	QTY.	QTY.
40	70053	Gear, 78 Teeth	1	0
40	70052	Gear, 70 Teeth	0	1
41	70046	Change Pinion, 26 Teeth	1	0
41	70043	Change Shaft	0	1
44	70051	Change Pinion, 34 Teeth	0	1
45	PA1269	Retaining Ring	0	1
52	70056	Key	0	1

*Recommended Spare Parts

PARTS LIST - PRODUCT SERIES 34

HOIST MOTOR

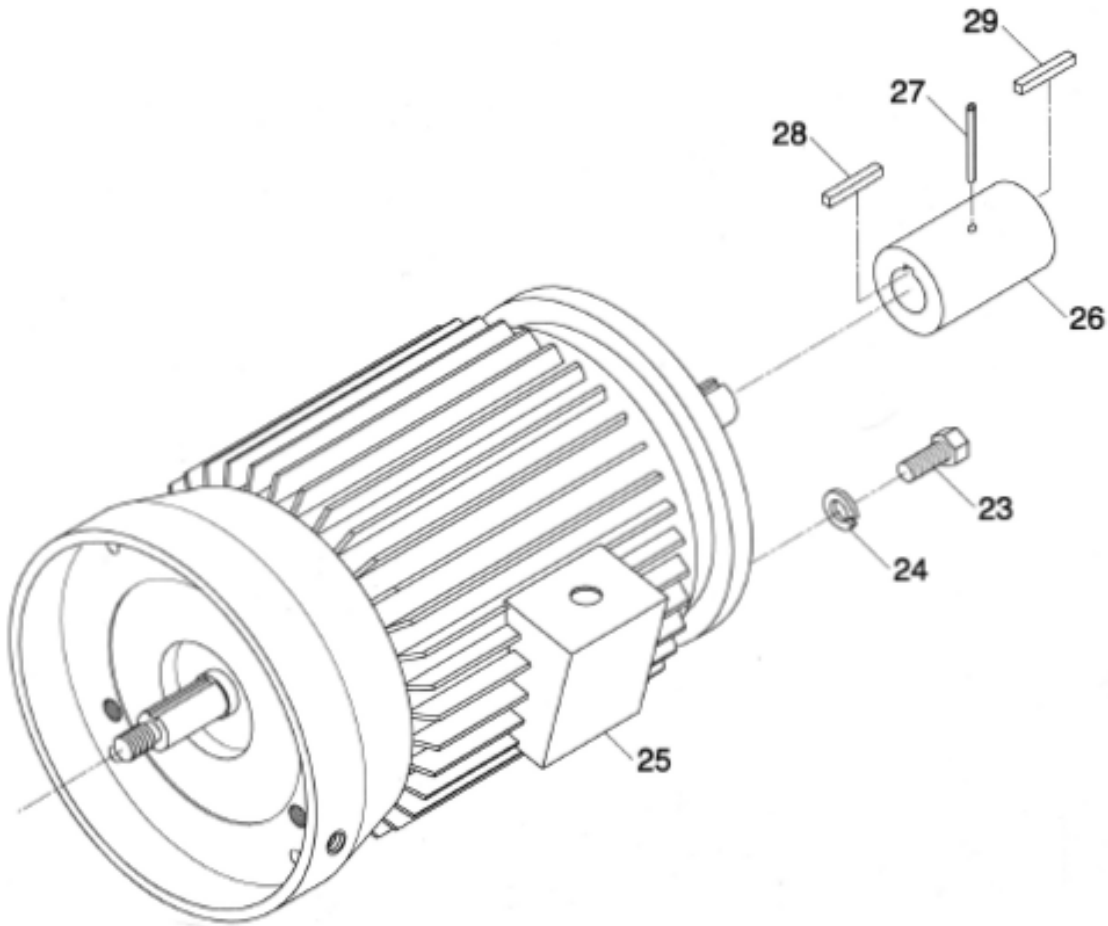

HOIST MOTOR PARTS

ITEM NO.	PART NO.	DESCRIPTION	QTY.
23	35-8-24C	Bolt, Hex Head	4
24	17-8C	Lockwasher	4
25	(b)	Hoist Motor	1
26	70055	Coupling	1
27	PA5366	Roll Pin	1
28	70863	Key(a)	1
29	70054	Key	1

No Recommended Spare Parts

NOTES:

- (a) Included with hoist motor. Also available individually.
- (b) Select standard hoist motor by part number according to motor specifications as follows:

PART NO.	VOLTAGE	HP	RPM	SPEED	FRAME
69777-13	208	15	1800	Single	256TC
69777-14	230/460				
69777-15	575				
69778-17	208	15/5	1800/600	Two	
69778-18	230				
69778-19	460				
69778-20	575				

For other specified special motors, refer to additional information pages supplied with manual.

PARTS LIST - PRODUCT SERIES 34

SUSPENSION - 2PS REEVING

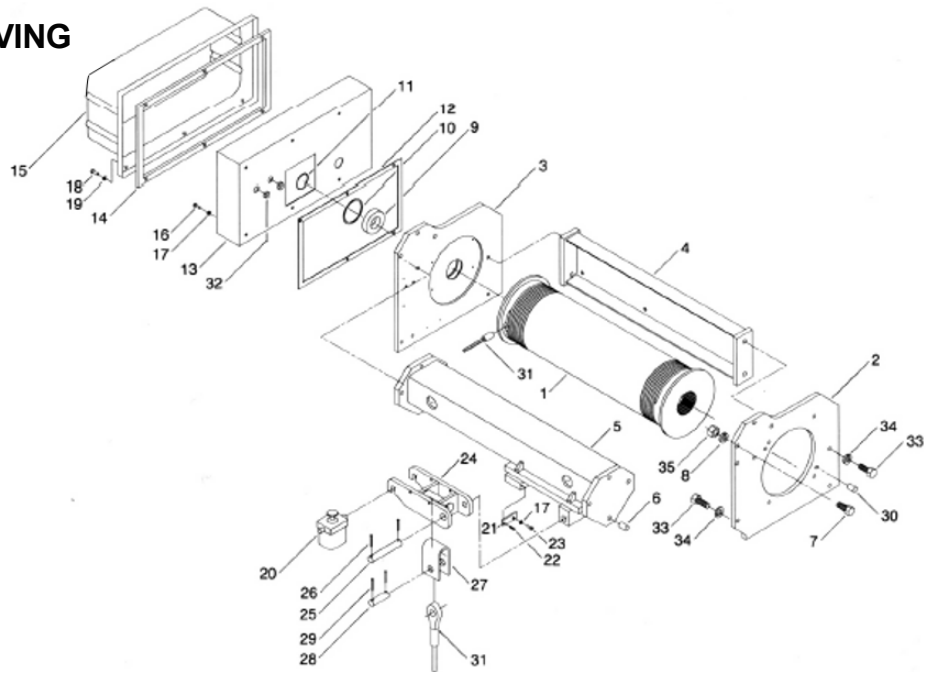

2PS SUSPENSION PARTS

ITEM NO.	DESCRIPTION	QTY.	21 FT. LIFT PART NO.	53 FT. LIFT PART NO.	71 FT. LIFT PART NO.	97 FT. LIFT PART NO.
1	Drum Single Grooving	1	70144-01	70144-02	70144-03	70144-04
2	End Plate Gear End	1	70148	70148	70148	70148
3	End Plate Control End	1	70149	70149	70149	70149
4	Side Frame	1	70172-01	70172-02	70172-03	70172-04
5	Frame Unit	1	70212-01	70212-02	70208-03	70208-04
6	Dowel Pin	4	PA7457	PA7457	PA7457	PA7457
7	Hex Head Bolt	4	35-12-44C	35-12-44C	35-12-44C	35-12-44C
8	Lockwasher	4	17-12C	17-12C	17-12C	17-12C
9	Bearing	1	PA7451	PA7451	PA7451	PA7451
10	Retaining Ring	1	PA7456	PA7456	PA7456	PA7456
11	Retaining Ring	1	PA7455	PA7455	PA7455	PA7455
12	Gasket	1	70139	70139	70139	70139
13	Enclosure	1	70138-01	70138-01	70138-01	70138-01
14	Gasket	1	58531	58531	58531	58531
15	Cover	1	52823	52823	52823	52823
16	Hex Head Bolt	6	35-4-6C	35-4-6C	35-4-6C	35-4-6C
17	Lockwasher	7	17-4C	17-4C	17-4C	17-4C
18	Captive Screw	6	58597	58597	58597	58597
19	Retaining Ring	6	PA6634	PA6634	PA6634	PA6634
20	Overload Cut-off 5 Ton	1	39170-04	39170-04	39170-04	39170-04
20	Overload Cut-off 7½ Ton	1	66291-04	66291-04	66291-04	66291-04
21	Keeper Plate	1	53219	53219	53219	53219
22	Roll Pin	1	PA4607	PA4607	PA4607	PA4607
23	Hex Head Bolt	1	35-4-8C	35-4-8C	35-4-8C	35-4-8C
24	Rope End Mounting Unit	1	69753	69753	69753	69753
25	Pin	1	69717	69717	69717	69717
26	Cotter Pin	2	PA1364	PA1364	PA1364	PA1364
27	Rope Hanger	1	70161	70161	70161	70161
28	Pin	1	70162	70162	70162	70162
29	Cotter Pin	2	PA1771	PA1771	PA1771	PA1771
30	Dowel Pin	2	PA7458	PA7458	PA7458	PA7458
31	Wire Rope Assembly (a)	1*	70146-01	70146-02	70146-03	70146-04
32	Grommet	2	PA7409	PA7409	PA7409	PA7409
33	Hex Head Bolt	10	35-10-28C	35-10-28C	35-10-28C	35-10-28C
34	Lockwasher	10	17-10C	17-10C	17-10C	17-10C
35	Hex Nut	4	22-12C	22-12C	22-12C	22-12C

* Recommended Spare Parts

NOTE: (a) Part numbers shown for Item 31, Wire Rope Assembly, are for standard hoists using 5/8 dia. 6x37 XIP wire rope. For special hoists using other size or type wire rope, refer to the wire rope part number listed in additional pages included with this manual; or contact Acco/Harrington or the distributor of the hoist.

PARTS LIST - PRODUCT SERIES 34

SUSPENSION - 4PS REEVING

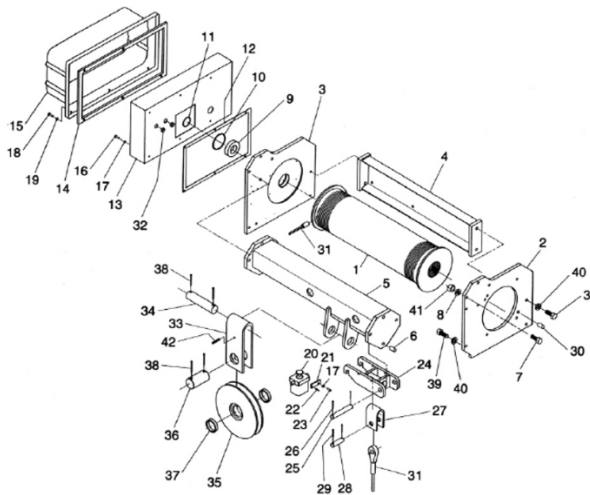

4PS SUSPENSION PARTS

ITEM NO.	DESCRIPTION	QTY.	25 FT. LIFT PART NO.	38 FT. LIFT PART NO.	61 FT. LIFT PART NO.	92 FT. LIFT PART NO.
1	Drum, Single Grooving	1	70144-03	70144-04	70144-05	70144-06
2	End Plate, Gear End	1	70148	70148	70148	70148
3	End Plate, Control End	1	70149	70149	70149	70149
4	Side Frame	1	70172-03	70172-04	70172-05	70172-06
5	Frame Unit	1	70169-03	70169-04	70203-05	70203-06
6	Dowel Pin	4	PA7457	PA7457	PA7457	PA7457
7	Hex Head Bolt	4	35-12-44C	35-12-44C	35-12-44C	35-12-44C
8	Lockwasher	4	17-12C	17-12C	17-12C	17-12C
9	Bearing	1	PA7451	PA7451	PA7451	PA7451
10	Retaining Ring	1	PA7456	PA7456	PA7456	PA7456
11	Retaining Ring	1	PA7455	PA7455	PA7455	PA7455
12	Gasket	1	70139	70139	70139	70139
13	Enclosure	1	70138-01	70138-01	70138-01	70138-01
14	Gasket	1	58531	58531	58531	58531
15	Cover	1	52823	52823	52823	52823
16	Hex Head Bolt	6	35-4-6C	35-4-6C	35-4-6C	35-4-6C
17	Lockwasher	7	17-4C	17-4C	17-4C	17-4C
18	Captive Screw	6	58597	58597	58597	58597
19	Retaining Ring	6	PA6634	PA6634	PA6634	PA6634
20	Overload Cut-off 10 Ton	1	39170-04	39170-04	39170-04	39170-04
20	Overload Cut-off 15 Ton	1	66291-04	66291-04	66291-04	66291-04
21	Keeper Plate	1	53219	53219	53219	53219
22	Roll Pin	1	PA4607	PA4607	PA4607	PA4607
23	Hex Head Bolt	1	35-4-8C	35-4-8C	35-4-8C	35-4-8C
24	Rope End Mounting Unit	1	69753	69753	69753	69753
25	Pin	1	69717	697174	69717	69717
26	Cotter Pin	2	PA1364	PA1364	PA1364	PA1364
27	Rope Hanger	1	70161	70161	70161	70161
28	Pin	1	70162	70162	70162	70162
29	Cotter Pin	2	PA1771	PA1771	PA1771	PA1771
30	Dowel Pin	2	PA7458	PA7458	PA7458	PA7458
31	Wire Rope Assembly (a)	1*	70146-13	70146-14	70146-15	70146-16
32	Grommet	2	PA7409	PA7409	PA7409	PA7409
33	Sheave Hanger	1	70158	70158	70158	70158
34	Pin	1	70159	70159	70159	70159
35	Polyamide Sheave with Bearing	1	69573	69573	69573	69573
35	Steel Sheave with Bearing	1	69574	69574	69574	69574
36	Pin	1	70160	70160	70160	70160
37	Spacer	2	69575-02	69575-02	69575-02	69575-02
38	Cotter Pin	4	PA1484	PA1484	PA1484	PA1484
39	Hex Head Bolt	10	35-10-28C	35-10-28C	35-10-28C	35-10-28C
40	Lockwasher	10	17-10C	17-10C	17-10C	17-10C
41	Hex Nut	4	22-12C	22-12C	22-12C	22-12C
42	Pin	1	PA3713	PA3713	PA3713	PA3713

* Recommended Spare Parts

NOTE: a) Part numbers shown for Item 31, Wire Rope Assembly, are for standard hoists using 5/8 dia. 6x37 XIP wire rope. For special hoists using other size or type wire rope, refer to the wire rope part number listed in additional pages included with this manual; or contact Acco/Harrington or the distributor of the hoist.

PARTS LIST - PRODUCT SERIES 34

SUSPENSION - 2PD REEVING

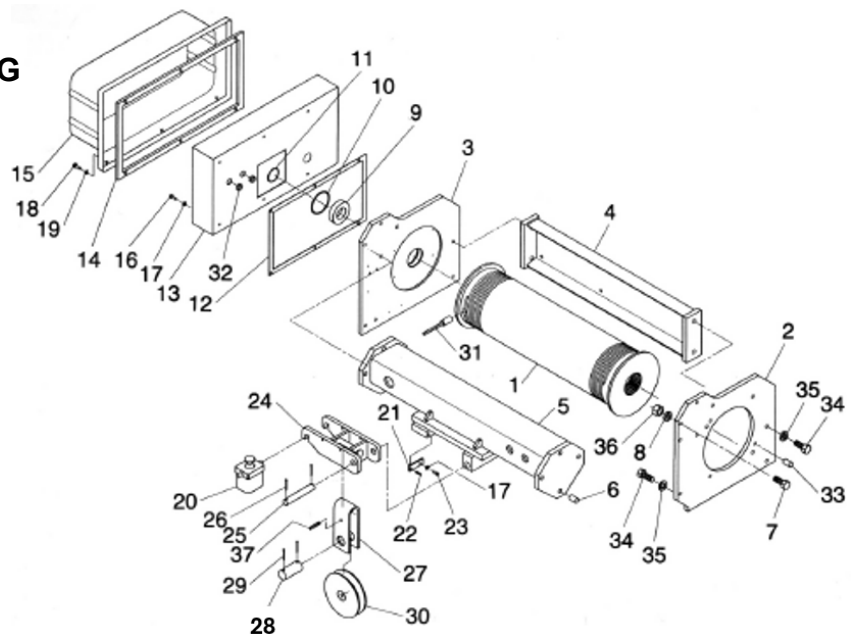

2PD SUSPENSION PARTS

ITEM NO.	DESCRIPTION	QTY.	20 FT. LIFT PART NO.	31 FT. LIFT PART NO.	47 FT. LIFT PART NO.	76 FT. LIFT PART NO.
1	Drum, Double Grooving	1	70145-02	70145-03	70145-04	70145-05
2	End Plate, Gear End	1	70148	70148	70148	70148
3	End Plate, Control End	1	70149	70149	70149	70149
4	Side Frame	1	70172-02	70172-03	70172-04	70172-05
5	Frame Unit	1	70209-02	70209-03	70209-04	70209-05
6	Dowel Pin	4	PA7457	PA7457	PA7457	PA7457
7	Hex Head Bolt	4	35-12-44C	35-12-44C	35-12-44C	35-12-44C
8	Lockwasher	4	17-12C	17-12C	17-12C	17-12C
9	Bearing	1	PA7451	PA7451	PA7451	PA7451
10	Retaining Ring	1	PA7456	PA7456	PA7456	PA7456
11	Retaining Ring	1	PA7455	PA7455	PA7455	PA7455
12	Gasket	1	70139	70139	70139	70139
13	Enclosure	1	70138-01	70138-01	70138-01	70138-01
14	Gasket	1	58531	58531	58531	58531
15	Cover	1	52823	52823	52823	52823
16	Hex Head Bolt	6	35-4-6C	35-4-6C	35-4-6C	35-4-6C
17	Lockwasher	7	17-4C	17-4C	17-4C	17-4C
18	Captive Screw	6	58597	58597	58597	58597
19	Retaining Ring	6	PA6634	PA6634	PA6634	PA6634
20	Overload Cut-off 5 Ton	1	39170-04	39170-04	39170-04	39170-04
20	Overload Cut-off 7 1/2 Ton	1	66291-04	66291-04	66291-04	66291-04
21	Keeper Plate	1	53219	53219	53219	53219
22	Roll Pin	1	PA4607	PA4607	PA4607	PA4607
23	Hex Head Bolt	1	35-4-8C	35-4-8C	35-4-8C	35-4-8C
24	Sheave Mounting Unit	1	69753	69753	69753	69753
25	Pin	1	69717	69717	69717	69717
26	Cotter Pin	2	PA1364	PA1364	PA1364	PA1364
27	Sheave Hanger	1	70059	70059	70059	70059
28	Pin	1	69747	69747	69747	69747
29	Cotter Pin	2	PA1771	PA1771	PA1771	PA1771
30	Polyamide Equalizing Sheave with Bearing	1	70150	70150	70150	70150
30	Steel Equalizing Sheave with Bearing	1	70199	70199	70199	70199
31	Wire Rope Assembly (a)	1*	70147-02	70147-03	70147-04	70147-05
32	Grommet	2	PA7409	PA7409	PA7409	PA7409
33	Dowel Pin	2	PA7458	PA7458	PA7458	PA7458
34	Hex Head Bolt	10	35-10-28C	35-10-28C	35-10-28C	35-10-28C
35	Lockwasher	10	17-10C	17-10C	17-10C	17-10C
36	Hex Nut	4	22-12C	22-12C	22-12C	22-12C
37	Pin	1	PA5342	PA5342	PA5342	PA5342

* Recommended Spare Parts

NOTE: (a) Part numbers shown for Item 31, Wire Rope Assembly, are for standard hoists using 1/2 dia. 6x37 XIP wire rope. For special hoists using other size or type wire rope, refer to the wire rope part number listed in additional pages included with this manual; or contact Acco/Harrington or the distributor of the hoist.

PARTS LIST - PRODUCT SERIES 34

SUSPENSION - 4PD REEVING

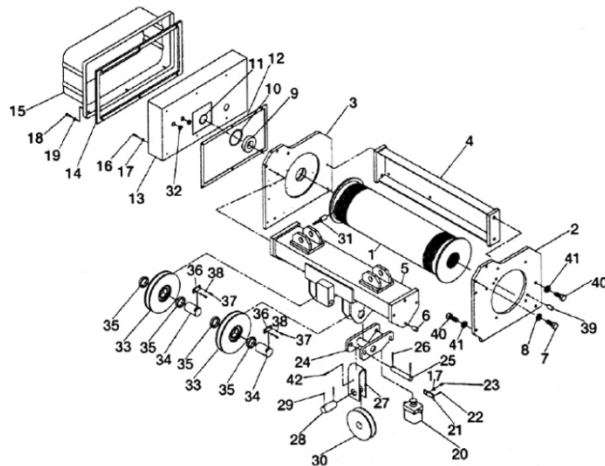

4PD SUSPENSION PARTS

ITEM NO.	DESCRIPTION	QTY.	20 FT. LIFT PART NO.	35 FT. LIFT PART NO.	54 FT. LIFT PART NO.
1	Drum Double Grooving	1	70145-04	70145-05	70145-06
2	End Plate Gear End	1	70148	70148	70148
3	End Plate Control End	1	70149	70149	70149
4	Side Frame	1	70172-04	70172-05	70172-06
5	Frame Unit	1	70194-04	70194-05	70194-06
6	Dowel Pin	4	(b)	(b)	(b)
7	Hex Head Bolt	4	35-12-32C	35-12-32C	35-12-32C
8	Lockwasher	4	17-12C	17-12C	17-12C
9	Bearing	1	PA7451	PA7451	PA7451
10	Retaining Ring	1	PA7456	PA7456	PA7456
11	Retaining Ring	1	PA7455	PA7455	PA7455
12	Gasket	1	70139	70139	70139
13	Enclosure	1	70138-01	70138-01	70138-01
14	Gasket	1	58531	58531	58531
15	Cover	1	52823	52823	52823
16	Hex Head Bolt	6	35-4-6C	35-4-6C	35-4-6C
17	Lockwasher	7	17-4C	17-4C	17-4C
18	Captive Screw	6	58597	58597	58597
19	Retaining Ring	6	PA6634	PA6634	PA6634
20	Overload Cut-off 10 Ton	1	39170-04	39170-04	39170-04
20	Overload Cut-off 15 Ton	1	66291-04	66291-04	66291-04
21	Keeper Plate	1	53219	53219	53219
22	Roll Pin	1	PA4607	PA4607	PA4607
23	Hex Head Bolt	1	35-4-8C	35-4-8C	35-4-8C
24	Sheave Mounting Unit	1	69959	69959	69959
25	Pin	1	69717	69717	69717
26	Cotter Pin	2	PA1364	PA1364	PA1364
27	Sheave Hanaer	1	70059	70059	70059
28	Pin	1	69747	69747	69747
29	Cotter Pin	2	PA1771	PA1771	PA1771
30	Polyamide Equalizing Sheave with Bearing	1	70150	70150	70150
30	Steel Equalizing Sheave with Bearing	1	70199	70199	70199
31*	Wire Rope Assembly (a)	1*	70147-14	70147-15	70147-16
32	Grommet	2	PA7409	PA7409	PA7409
33	Polyamide Running Sheave with Bearing	2	69567	69567	69568
33	Steel Running Sheave with Bearing	2	69568	69568	69567
34	Axle	2	69686-02	69686-02	69686-02
35	Spacer	4	69569-02	69569-02	69569-02
36	Keeper Plate	2	50733	50733	50733
37	Screw	4	1-01-8	1-01-8	1-01-8
38	Lockwasher	4	17-010C	17-010C	17-010C
39	Dowel Pin	2	PA7458	PA7458	PA7458
40	Hex Head Bolt	10	35-10-28C	35-10-28C	35-10-28C
41	Lockwasher	10	17-10C	17-10C	17-10C
42	Pin	1	PA5342	PA5342	PA5342

*Recommended Spare Parts

NOTES: (a) Part numbers shown for Item 31, Wire Rope Assembly, are for standard hoists using 1/2 dia. 6x37 XIP wire rope. For special hoists using other size or type wire rope, refer to the wire rope part number listed in additional pages included with this manual; or contact Acco/Harrington or the distributor of the hoist.
(c) PA7487 except for winch. For winch, use PA7457.

PARTS LIST - PRODUCT SERIES 34

LOAD BLOCK - 2PS REEVING 5/8" ROPE DIAMETER

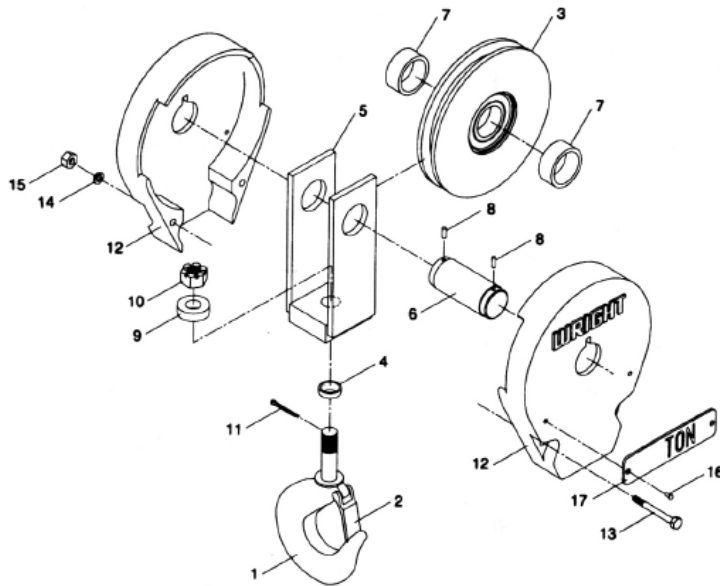

- Load Block Assembly 69552-01 - Steel Spring Latch Type Hook, Polyamide Sheave
- Load Block Assembly 69552-02 - Bullard Swivel Latch Type Hook, Polyamide Sheave
- Load Block Assembly 69552-03 - Bronze Spring Latch Type Hook, Polyamide Sheave
- Load Block Assembly 69552-04 - Steel Spring Latch Type Hook, Steel Sheave
- Load Block Assembly 69552-05 - Bullard Swivel Latch Type Hook, Steel Sheave
- Load Block Assembly 69552-06 - Bronze Spring Latch Type Hook, Steel Sheave

LOAD BLOCK PARTS

ITEM NO.	DESCRIPTION	QTY	STEEL SPRING LATCH TYPE HOOK	BULLARD SWIVEL LATCH TYPE HOOK	BRONZE SPRING LATCH TYPE HOOK
1	Hook without hole in tip	1	58012 (a)	58013	58014 (a)
1	Hook with hole in tip	1	70893 (a)	N/A	70901 (a)
2	Latch for hook without hole in tip	1	PA5327 (a)	N/A	PA5329 (a)
2	Latch for hook with hole in tip	1	PA7583 (a)	N/A	PA7585 (a)
3	Polyamide Sheave with Bearing	1	69573	69573	69573
3	Steel Sheave with Bearing	1	69574	69574	69574
4	Spacer	0	N/A	N/A	N/A
5	Frame	1	69571	69571	69571
6	Axle	1	69572	69572	69572
7	Spacer	2	69575	69575	69575
8	Roll Pin	2	PA4607	PA4607	PA4607
9	Thrust Bearing	1	PA5832	PA5832	PA5832
10	Slotted Hex Nut	1	26-24	26-24	26-24
11	Cotter Pin	1	PA1932	PA1932	PA1932
12	Cover	2	58008	58008	58008
13	Hex Head Bolt	2	35-8-52	35-8-52	35-8-52
14	Lockwasher	2	17-8C	17-8C	17-8C
15	Hex Nut	2	22-8	22-8	22-8
16	Drive Screw	4	PA893	PA893	PA893
17	Capacity Plate	2	(b)	(b)	(b)

No Recommended Spare Parts

NOTES:

(a) Current style Spring Latch Hooks are being phased out by Acco/Harrington's supplier. The new style Spring Latch Hooks have a hole in the tip of the hook. This hole allows the addition of a cotter pin to prevent the latch from opening. Cotter pin is not supplied by Acco/Harrington. New style hooks are interchangeable with old style hooks, but new style hooks have a thicker cross section. Latches are not interchangeable between the two style hooks. As soon as stock of current style hook is depleted, current style hook will no longer be available. Latches for current style hooks will continue to be available. When ordering, identify whether or not hook has a hole in the tip and select part numbers accordingly from the above chart.

(b) Capacity Plate part numbers:

- 5 Ton - 69683-050 5 tonne - 69683-1050
- 7½ Ton - 69683-075 7½ tonne - 69683-1075

PARTS LIST - PRODUCT SERIES 34

LOAD BLOCK - 4PS REEVING 5/8" ROPE DIAMETER

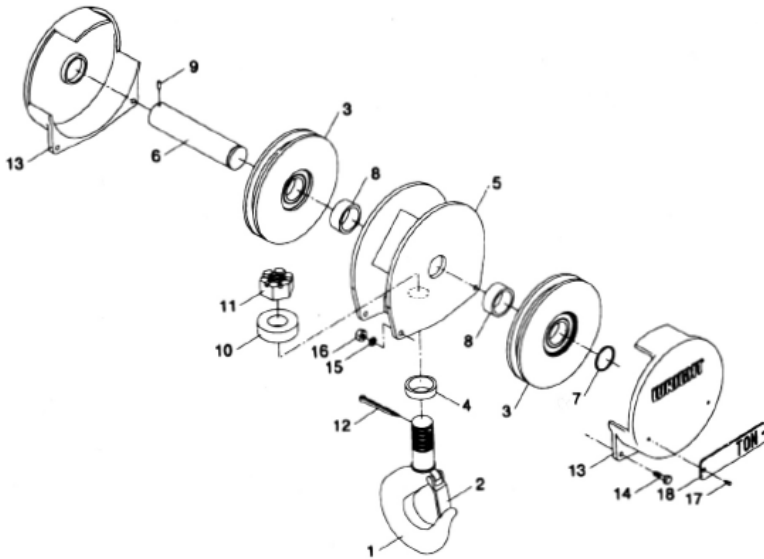

Load Block Assembly 69556-01 - Steel Spring Latch Type Hook, Polyamide Sheave
 Load Block Assembly 69556-02 - Bullard Swivel Latch Type Hook, Polyamide Sheave
 Load Block Assembly 69556-03 - Steel Spring Latch Type Hook, Steel Sheave
 Load Block Assembly 69556-04 - Bullard Swivel Latch Type Hook, Steel Sheave

LOAD BLOCK PARTS

ITEM NO.	DESCRIPTION	QTY	STEEL SPRING LATCH TYPE HOOK	BULLARD SWIVEL LATCH TYPE HOOK
1	Hook without hole in tip	1	43518 (a)	59824
1	Hook with hole in tip	1	70943 (a)	N/A
2	Latch for hook without hole in tip	1	PA5327 (a)	N/A
2	Latch for hook with hole in tip	1	PA7584 (a)	N/A
3	Polyamide Sheave with Bearing	2	69573	69573
3	Steel Sheave with Bearing	2	69574	69574
4	Spacer	0	N/A	N/A
5	Frame	1	69597	69597
6	Axle	1	69598	69598
7	Retaining Ring	1	PA7190	PA7190
8	Spacer	2	69575	69575
9	Roll Pin	1	PA4607	PA4607
10	Thrust Bearing	1	PA2138	PA2138
11	Slotted Hex Nut	1	26-28	26-28
12	Cotter Pin	1	PA2551	PA2551
13	Cover	2	69600	69600
14	Hex Head Bolt	4	35-8-32	35-8-32
15	Lockwasher	4	17-8C	17-8C
16	Hex Nut	4	22-8	22-8
17	Drive Screw	4	PA893	PA893
18	Capacity Plate	2	(b)	(b)

No Recommended Spare Parts

NOTES:

(a) Current style Spring Latch Hooks are being phased out by Acco/Harrington's supplier. The new style Spring Latch Hooks have a hole in the tip of the hook. This hole allows the addition of a cotter pin to prevent the latch from opening. Cotter pin is not supplied by Acco/Harrington. New style hooks are interchangeable with old style hooks, but new style hooks have a thicker cross section. Latches are not interchangeable between the two style hooks. As soon as stock of current style hook is depleted, current style hook will no longer be available. Latches for current style hooks will continue to be available. When ordering, identify whether or not hook has a hole in the tip and select part numbers accordingly from the above chart.

(b) Capacity Plate part numbers:

10 Ton - 69683-100 10 tonne - 69683-1100

15 Ton - 69683-150 15 tonne - 69683-1150

PARTS LIST - PRODUCT SERIES 34

LOAD BLOCK - 2PD REEVING 1/2" ROPE DIAMETER

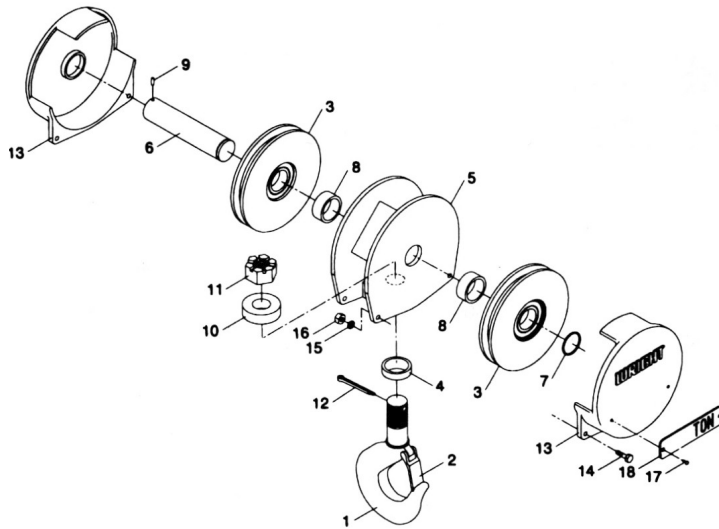

- Load Block Assembly 69555-01 - Steel Spring Latch Type Hook, Polyamide Sheave
- Load Block Assembly 69555-02 - Bullard Swivel Latch Type Hook, Polyamide Sheave
- Load Block Assembly 69555-03 - Bronze Spring Latch Type Hook, Polyamide Sheave
- Load Block Assembly 69555-04 - Steel Spring Latch Type Hook, Steel Sheave
- Load Block Assembly 69555-05 - Bullard Swivel Latch Type Hook, Steel Sheave
- Load Block Assembly 69555-06 - Bronze Spring Latch Type Hook, Steel Sheave

LOAD BLOCK PARTS

ITEM NO.	DESCRIPTION	QTY	STEEL SPRING LATCH TYPE HOOK	BULLARD SWIVEL LATCH TYPE HOOK	BRONZE SPRING LATCH TYPE HOOK
1	Hook without hole in tip	1	58012 (a)	58013	58014 (a)
1	Hook with hole in tip	1	70893 (a)	N/A	70901 (a)
2	Latch for hook without hole in tip	1	PA5327 (a)	N/A	PA5329 (a)
2	Latch for hook with hole in tip	1	PA7583 (a)	N/A	PA7585 (a)
3	Polyamide Sheave with Bearing	2	69567	69567	69567
3	Steel Sheave with Bearing	2	69568	69568	69568
4	Spacer	0	N/A	N/A	N/A
5	Frame	1	69591	69591	69591
6	Axle	1	69592	69592	69592
7	Retaining Ring	1	PA6941	PA6941	PA6941
8	Spacer	2	69569	69569	69569
9	Roll Pin	1	PA4607	PA4607	PA4607
10	Thrust Bearing	1	PA5832	PA5832	PA5832
11	Slotted Hex Nut	1	26-24	26-24	26-24
12	Cotter Pin	1	PA1932	PA1932	PA1932
13	Cover	2	69594	69594	69594
14	Hex Head Bolt	4	35-6-32	35-6-32	35-6-32
15	Lockwasher	4	17-6C	17-6C	17-6C
16	Hex Nut	4	22-6	22-6	22-6
17	Drive Screw	4	PA893	PA893	PA893
18	Capacity Plate	2	(b)	(b)	{b}

No Recommended Spare Parts

NOTES:

(a) Current style Spring Latch Hooks are being phased out by Acco/Harrington's supplier. The new style Spring Latch Hooks have a hole in the tip of the hook. This hole allows the addition of a cotter pin to prevent the latch from opening. Cotter pin is not supplied by Acco/Harrington. New style hooks are interchangeable with old style hooks, but new style hooks have a thicker cross section. Latches are not interchangeable between the two style hooks. As soon as stock of current style hook is depleted, current style hook will no longer be available. Latches for current style hooks will continue to be available. When ordering, identify whether or not the hook has a hole in the tip and select part numbers accordingly from the above chart.

(b) Capacity Plate part numbers:

- 5 Ton - 69683-050 5 tonne - 69683-1050
- 7½ Ton - 69683-075 7½ tonne - 69683-1075

PARTS LIST - PRODUCT SERIES 34

LOAD BLOCK - 4PD REEVING 1/2" ROPE DIAMETER

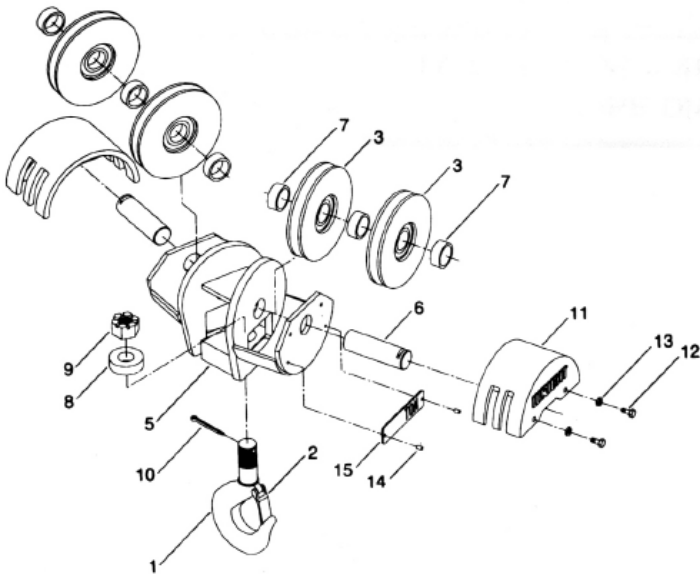

- Load Block Assembly 69559-01 - Steel Spring Latch Type Hook, Polyamide Sheave
- Load Block Assembly 69559-03 - Bullard Swivel Latch Type Hook, Polyamide Sheave
- Load Block Assembly 69559-02 - Steel Spring Latch Type Hook, Steel Sheave
- Load Block Assembly 69559-04 - Bullard Swivel Latch Type Hook, Steel Sheave

LOAD BLOCK PARTS

ITEM NO.	DESCRIPTION	QTY	STEEL SPRING LATCH TYPE HOOK	BULLARD SWIVEL LATCH TYPE HOOK
1	Hook without hole in tip	1	43577 (a)	71074
1	Hook with hole in tip	1	70944 (a)	N/A
2	Latch for hook without hole in tip	1	PA5329 (a)	N/A
2	Latch for hook with hole in tip	1	PA7585 (a)	N/A
3	Polyamide Sheave with Bearing	4	69567	69567
3	Steel Sheave with Bearing	4	69568	69568
4	Spacer	0	N/A	N/A
5	Frame	1	69677	69677
6	Axle	2	69686	69686
7	Spacer	4	69569-04	69569-04
8	Thrust Bearing	1	PA1248	PA1248
9	Slotted Hex Nut	1	26-32	26-32
10	Cotter Pin	1	PA3796	PA3796
11	Cover	2	69673	69673
12	Hex Head Bolt	4	35-6-12C	35-6-12C
13	Lockwasher	4	17-6C	17-6C
14	Drive Screw	4	PA893	PA893
15	Capacity Plate	2	(b)	(b)
16	Spacer	2	69569-03	69569-03

No Recommended Spare Parts

NOTES:

(a) Current style Spring Latch Hooks are being phased out by Acco/Harrington's supplier. The new style Spring Latch Hooks have a hole in the tip of the hook. This hole allows the addition of a cotter pin to prevent the latch from opening. Cotter pin is not supplied by Acco/Harrington. New style hooks are interchangeable with old style hooks, but new style hooks have a thicker cross section. Latches are not interchangeable between the two style hooks. As soon as stock of current style hook is depleted, current style hook will no longer be available. Latches for current style hooks will continue to be available. When ordering, identify whether or not the hook has a hole in the tip and select part numbers accordingly from the above chart.

(b) Capacity Plate part numbers:

- 10 Ton - 69683-100 10 tonne - 69683-1100
- 15 Ton - 69683-150 15 tonne - 69683-1150

PARTS LIST - PRODUCT SERIES 34

GRAVITY LIMIT SWITCH

Gravity Limit Switch Assembly 70265-01 - Used on Series 32 and Series 33 2PS, 2PD, and 4PD hoists.

Gravity Limit Switch Assembly 70265-02 - Used on Series 33 4PS, Series 34, and Series 35 hoists.

GRAVITY LIMIT SWITCH PARTS

ITEM NO.	PART NO.	DESCRIPTION	QTY. 70265-01	QTY. 70265-02
1	70262	Enclosure	1	1
2	PA3598	Bushing	(a)	(a)
3	69793	Arm	1	1
4	3-08-8C	Screw	1	1
5	70264	Cam	1	1
6	3-05-14C	Screw	2	2
7	PA7400	Spring	1	1
8	3-05-2C	Screw	3	3
9	3-010-6C	Screw	1	1
10	61717	Switch Unit	1	1
11	70263	Shaft	1	1
12	64104	Insulator	1	1
13	PA3810	Spring Pin	1	1
14	PA5155	Self-tapping Screw	2	2
15	69804	Cover	1	1
16	69805	Gasket	1	1
17	PA2242	Oval Cable Sleeve	2	2
18	PA3113	Wire Rope	A.R.	A.R.
19	69827	Weight Half	2	0
20	35-4-16C	Bolt	2	0
21	22-4C	Hex Nut	2	2
22	17-4C	Lockwasher	2	2
23	19-08C	Lockwasher, Int. Tooth	1	1
24	3-010-6C	Screw	0	1
25	30-01C	Hex Nut	0	1
26	35-4-24C	Bolt	0	2
27	A2007L1	Weight Half, Left	0	1
28	A2007R1	Weight Half, Right	0	1

No Recommended Spare Parts

NOTES:

(a) Included with Item 1.

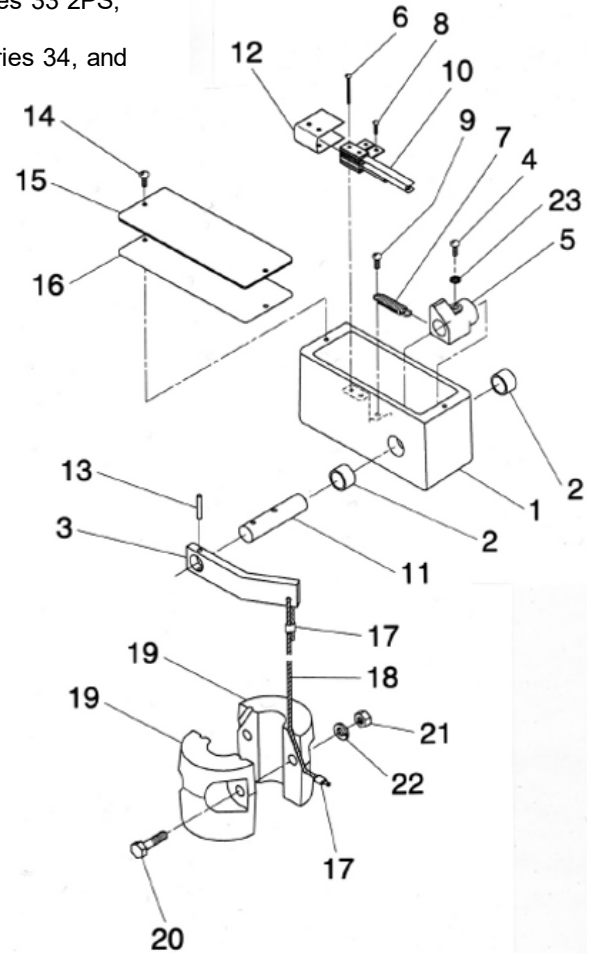

ASSEMBLY-01

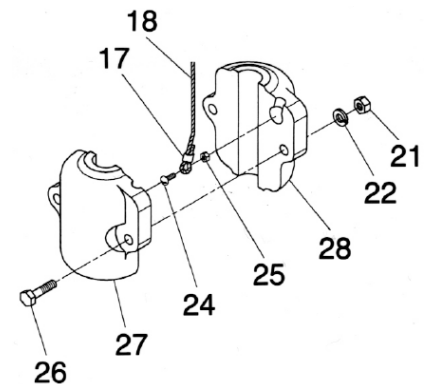

ASSEMBLY-02

(b) Gravity limit switch attached to hoist frame with two (2) Round Head Screws, Part No. 3-010-16C, and two (2) Locknuts, Part No. PA2423.

PARTS LIST - PRODUCT SERIES 34

GEARED LIMIT SWITCH

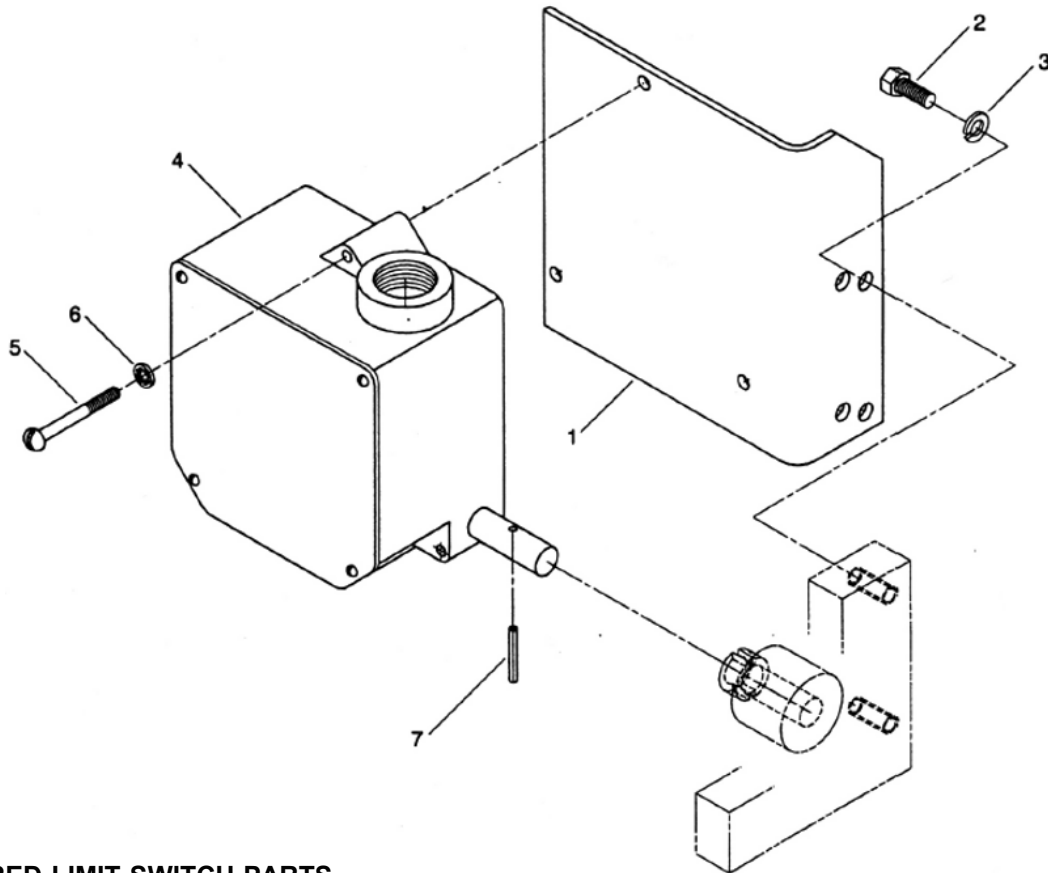

GEARED LIMIT SWITCH PARTS

ITEM NO.	PART NO.	DESCRIPTION	QTY.
1	69965	Mounting Plate	1
2	35-4-8C	Hex Head Bolt	2
3	17-4C	Lockwasher	2
4 (a)	61649-07	Geared Limit Switch 2 Circuit - 40:1 Ratio - 38 Max. Turns	1
	61649-05	Geared Limit Switch 4 Circuit - 40:1 Ratio - 38 Max. Turns	1
	61649-08	Geared Limit Switch 2 Circuit - 80:1 Ratio - 75 Max. Turns	1
	61649-06	Geared Limit Switch 4 Circuit - 80:1 Ratio - 75 Max. Turns	1
	61649-01	Geared Limit Switch 2 Circuit - 111:1 Ratio - 104 Max. Turns	1
	61649-03	Geared Limit Switch 4 Circuit - 111:1 Ratio - 104 Max. Turns	1
	61649-10	Geared Limit Switch 2 Circuit - 222:1 Ratio - 208 Max. Turns	1
	61649-12	Geared Limit Switch 4 Circuit - 222:1 Ratio - 208 Max. Turns	1
5	3-010-24C	Round Head Screw	3
6	19-010C	Lockwasher	3
7	PA3810	Drive Pin	1

No Recommended Spare Parts

NOTE:

(a) For Geared Limit Switch selection, the maximum possible number of input shaft turns must be greater than the total number of grooves on a single reeved drum or the total number of grooves per side on a double reeved drum. With standard grooving, the following drum numbers are the maximum length drums on which the indicated switch ratios can be used.

40:1 Ratio can be used up to 2PS and 4PS Drum Number 2 or 2PD and 4PD Drum Number 4.

80:1 Ratio can be used up to 2PS and 4PS Drum Number 4 or 2PD and 4PD Drum Number 5.

111:1 Ratio can be used up to 2PS and 4PS Drum Number 5 or 2PD and 4PD Drum Number 6.

222:1 Ratio can be used up to 2PS and 4PS Drum Number 6.

PARTS LIST - PRODUCT SERIES 34

HOIST RECTIFIED D.C. BRAKE CONTROL

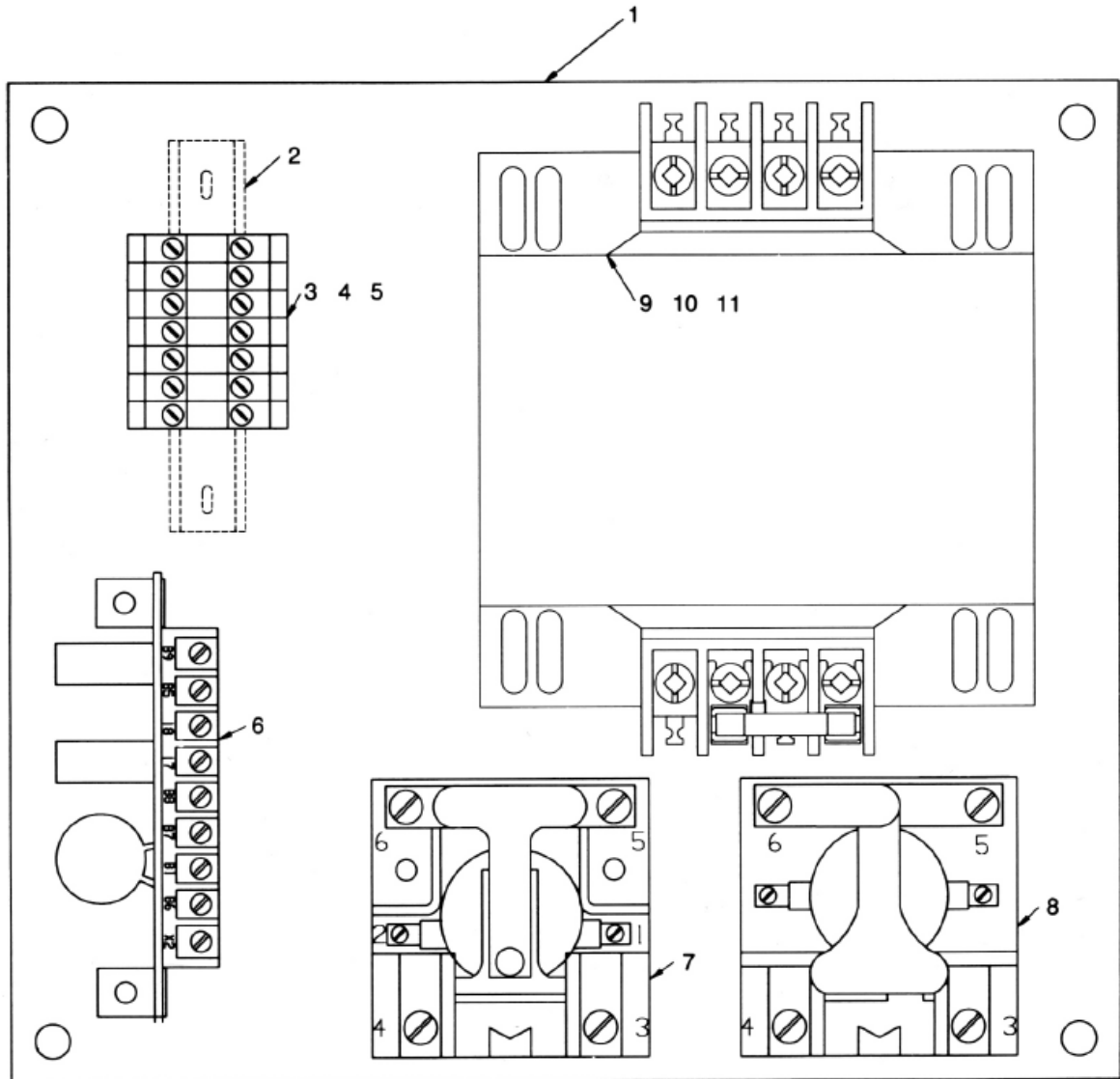

REPLACEMENT PARTS

ITEM NO.	PART NUMBER	DESCRIPTION
1	86828	Panel, Drilled
2	86714-12	Din Rail, Pre-cut, 3-1/2" L.
3	86710-05	Terminal, End Anchor
4	86710-07	Terminal, End Barrier
5	86710-01	Terminal, Control
6*	86712	Brake Circuit Control Board
7*	PA6496	Relay, Brake Ctrl. (BC) for 115V. Control
	PA6373	Relay, Brake Ctrl. (BC) for 24V. Control

ITEM NO.	PART NUMBER	DESCRIPTION
8*	PA6254	Relay, Brake (BR) for 115V. Control
	PA6255	Relay, Brake (BR) for 24V. Control
9	52429-80	Transformer Fuse Holder
10*	PA6334	Transformer Fuse (350VA)
	PA6335	Transformer Fuse (500VA)
11	52429-09	Transformer, 350VA, 200-115
	52429-21	Transformer, 350VA, 230/460-115
	52429-44	Transformer, 350VA, 575-115
	52429-10	Transformer, 500VA, 200-115
	52429-22	Transformer, 500VA, 230/460-115
	52429-45	Transformer, 500VA, 575-115

*Recommended Spare Parts

PARTS LIST - PRODUCT SERIES 34

BASIC CONTROL COMPONENTS

SINGLE OR TWO SPEED HOIST, LUG MTD., PLAIN OR GEARED TROLLEY OR SINGLE SPEED HOIST SINGLE SPEED TROLLEY COMBINATION

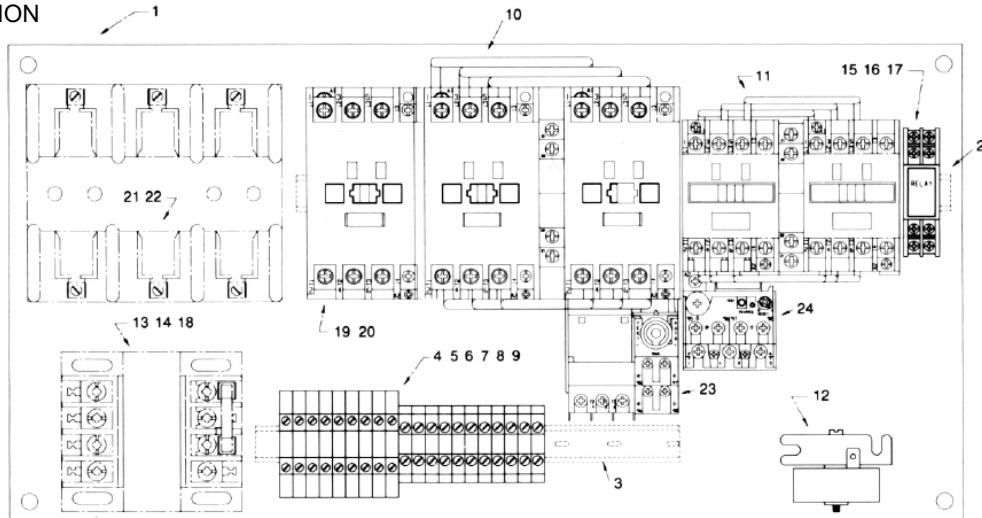

REPLACEMENT PARTS

ITEM NO.	PART NUMBER	DESCRIPTION
1	86822	Panel, Drilled
2	86714-06	DIN Rail, Pre-cut, 12"
3	86714-02	DIN Rail, Pre-cut, 8"
4	86710-04	Terminal, Grounding
5	86710-05	Terminal, End Anchor
6	86710-06	Terminal, End Barrier, Power
7	86710-07	Terminal, End Barrier, Control
8	86710-01	Terminal, Control
9	86710-02	Terminal, Power
10*	86729-01	Contact, Reversing, (or Two Speed) 115 V (Hoist) Size C, For Two Speed Contactor remove load side jumper wires (black wires)
	86729-02	Contact, Reversing, (or Two Speed) 24 V (Hoist) Size C, For Two Speed Contactor remove load side jumper wires (black wires)
	86730-01	Contact, Reversing (or Two Speed) 115 V (Hoist) Size D, For Two Speed Contactor remove load side jumper wires (black wires)
	86730-02	Contact, Reversing (or Two Speed) 24 V (Hoist) Size D, For Two Speed Contactor remove load side jumper wires (black wires)
11*	86727-01	Contact, Reversing (or Two Speed) 115 V (Trolley) Size B, For Two Speed Contactor remove load side jumper wires (black wires)
	86727-02	Contact, Reversing (or Two Speed) 115 V (Trolley) Size B, For Two Speed Contactor remove load side jumper wires (black wires)
12	PA7103	Time Capsule, 115 V (Two Speed Only)
	PA7104	Time Capsule, 24 V (Two Speed Only)

ITEM NO.	PART NUMBER	DESCRIPTION
13	52429-80	Transformer Fuse Clip (24 V controls only)
14*	PA7330	Transformer Fuse (24 V controls only) 50 VA
	PA6334	Transformer Fuse (24 V controls only) 75 VA
15•	PA7382	Relay, Control, 115 V (Two Speed Only)
	PA7383	Relay, Control, 24 V (Two Speed Only)
16	PA7384	Relay, Socket
17	PA7385	Relay, Retainer Clip
18	52429-XX	Transformer (24 V controls only) -52 for 200 V; -26 for 230/460 V; -64 for 575 V Supply (50 VA)
	52429-XX	Transformer (24 V controls only) -53 for 200 V; -27 for 230/460 V; -65 for 575 V Supply (75 VA)
19	86733-01	Mainline Contactor, 115 V Size C (Optional)
	86733-02	Mainline Contactor, 24 V Size C (Optional)
	86734-01	Mainline Contactor, 115 V Size D (Optional)
	86734-02	Mainline Contactor, 24 V Size D (Optional)
20	86737-10	Contact Block, Aux. (used with Mainline Contactor)
	PA7341	Fuse Block, Mtr. Ckt. 30A. (Optional)
21	PA7342	Fuse Block, Mtr. Ckt. 60A. (Optional)
22*	86709-XX	Fuse, Mtr. Ckt. (Optional) see note below
23	86736-XX	Overload Relay, Hoist (Optional) see note below
24	86736-XX	Overload Relay, Trolley (Optional) see note below
Not Shown	69505-02	Danger Label, Electrical

*Recommended Spare Parts

NOTE:

When ordering Motor Circuit Fuses or Overload Relays, provide as much information about the hoist as possible. Hoist serial number, motor H.P's., full load currents, supply voltage, etc.

PARTS LIST - PRODUCT SERIES 34

BASIC CONTROL COMPONENTS

SINGLE OR TWO SPEED HOIST AND TROLLEY CONTROL WITH ACM & SIZE "C" HOIST CONTACTOR

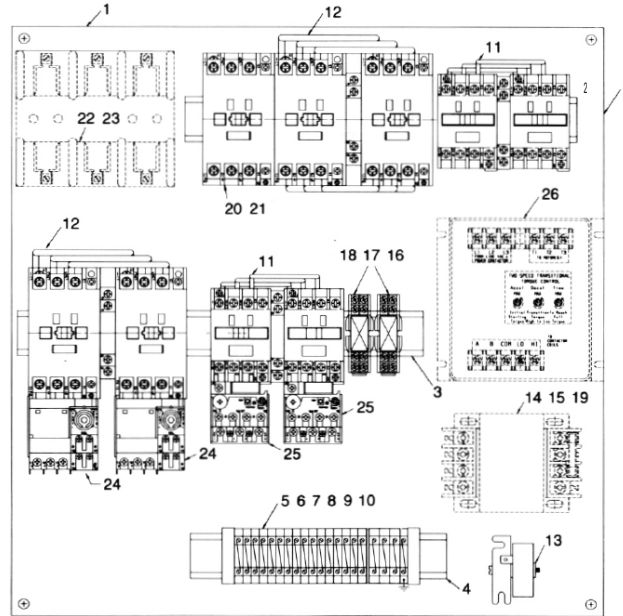

REPLACEMENT PARTS

ITEM NO.	PART NUMBER	DESCRIPTION
1	86824	Panel, Drilled
2	86714-11	DIN Rail, Pre-cut, 13" L.
3	86714-10	DIN Rail, Pre-cut, 12.5" L.
4	86714-02	DIN Rail, Pre-cut, 8" L.
5	86710-04	Terminal, Grounding
6	86710-05	Terminal, End Anchor
7	86710-06	Terminal, End Barrier, Power
8	86710-07	Terminal, End Barrier, Control
9	86710-01	Terminal, Control
10	86710-02	Terminal, Power
11*	86727-01	Contact, Reversing, (or Two Speed) 115 V (Trolley) Size B, For Two Speed Contactor remove load side jumper wires (black wires)
	86727-02	Contact, Reversing, (or Two Speed) 24 V (Trolley) Size B, For Two Speed Contactor remove load side jumper wires (black wires)
12*	86729-01	Contact, Reversing, (or Two Speed) 115 V (Hoist) Size C, For Two Speed Contactor remove load side jumper wires (black wires)
	86729-02	Contact, Reversing, (or Two Speed) 24 V (Hoist) Size C, For Two Speed Contactor remove load side jumper wires (black wires)
13	PA7103	Time Capsule, 115 V (Two Speed Only)
	PA7104	Time Capsule, 24 V (Two Speed Only)
14	52429-80	Transformer Fuse Clip (24 V Models Only)
15*	PA7330	Transformer Fuse (24 V Models Only)

ITEM NO.	PART NUMBER	DESCRIPTION
16	PA7382	Relay, Control, 115 V (Two Speed Only)
	PA7383	Relay, Control, 24 V (Two Speed Only)
17	PA7384	Relay, Socket (Two Speed Only)
18	PA7385	Relay, Hold Down Clip
19	52429-XX	Transformer (24 V controls only) -52 for 200 V; -26 for 230/460 V; -64 for 575 V Supply (SOVA)
20	86733-01	Mainline Contactor, 115 V Size C (optional)
	86733-02	Mainline Contactor, 24 V Size C (optional)
21	86737-10	Contact Block, Aux. (used with Mainline Contactor)
22	PA7341	Fuse Block, Motor Ckt. 30A. (Optional)
	PA7342	Fuse Block, Motor Ckt. 60A. (Optional)
23*	86709-XX	Fuse, Motor Circuit (Optional) see note below
24	86736-XX	Overload Relay, Hoist (Optional) see note below
25	86736-XX	Overload Relay, Trolley (Optional) see note below
26	86715-017	ACM, S.S., 1 H.P. Max. 200-230 V, 2 H.P. Max 460 V
	86715-019	ACM, S.S., 2.5 H.P. Max. 200-230 V, 5 H.P. Max 460 V
	86715-018	ACM, 2S., 1 H.P. Max. 200-230 V, 2 H.P. Max 460 V
	86715-020	ACM, 2S., 2.5 H.P. Max. 200-230 V, 5 H.P. Max 460 V
	86715-002	ACM, S.S., 2 H.P. Max. 575 V
	86715-004	ACM, S.S., 5 H.P. Max. 575 V
	86715-006	ACM, 2S., 2 H.P. Max. 575 V
	86715-008	ACM, 2S., 5 H.P. Max. 575 V
Not Shown	69505-02	Danger Label, Electrical

*Recommended Spare Parts

NOTE:

When ordering Motor Circuit Fuses or Overload Relays, provide as much information about the hoist as possible. Hoist serial number, motor H.P.'s., full load currents, supply voltage, etc. ACM's listed are for 115 V control only. For 24 V control, order by description.

PARTS LIST - PRODUCT SERIES 34

BASIC CONTROL COMPONENTS

SINGLE OR TWO SPEED HOIST AND TROLLEY CONTROL WITH SIZE "D" HOIST CONTACTOR

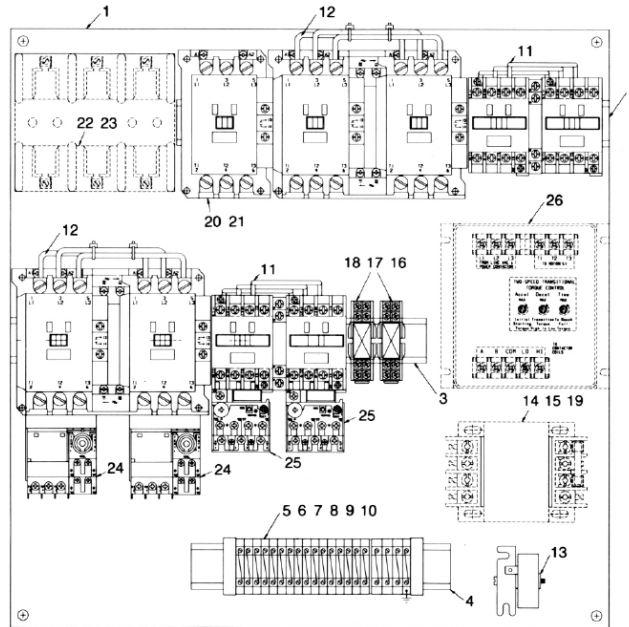

REPLACEMENT PARTS

ITEM NO.	PART NUMBER	DESCRIPTION
1	86824	Panel, Drilled
2	86714-11	DIN Rail, Pre-cut, 13" L.
3	86714-10	DIN Rail, Pre-cut, 12.5" L.
4	86714-02	DIN Rail, Pre-cut, 8" L.
5	86710-04	Terminal, Grounding
6	86710-05	Terminal, End Anchor
7	86710-06	Terminal, End Barrier, Power
8	86710-07	Terminal, End Barrier, Control
9	86710-01	Terminal, Control
10	86710-02	Terminal, Power
11*	86727-01	Contact, Reversing, (or Two Speed) 115 V (Trolley) Size B, For Two Speed Contactor remove load side jumper wires (black wires)
	86727-02	Contact, Reversing, (or Two Speed) 24 V (Trolley) Size B, For Two Speed Contactor remove load side jumper wires (black wires)
12*	86730-01	Contact, Reversing, (or Two Speed) 115 V (Hoist) Size D, For Two Speed Contactor remove load side jumper wires (black wires)
	86730-02	Contact, Reversing, (or Two Speed) 24 V (Hoist) Size D, For Two Speed Contactor remove load side jumper wires (black wires)
13	PA7103	Time Capsule, 115 V (Two Speed Only)
	PA7104	Time Capsule, 24 V (Two Speed Only)
14	52429-80	Transformer Fuse Clip (24 V Models Only)
15*	PA6335	Transformer Fuse (24 V Models Only)

ITEM NO.	PART NUMBER	DESCRIPTION
16	PA7382	Relay, Control, 115 V (Two Speed Only)
	PA7383	Relay, Control, 24 V (Two Speed Only)
17	PA7384	Relay, Socket (Two Speed Only)
18	PA7385	Relay, Hold Down Clip
19	52429-XX	Transformer (24 V controls only) -54 for 200 V; -28 for 230/460 V; -66 for 575 V Supply (100 VA)
20	86734-01	Mainline Contactor, 115 V Size D (optional)
	86734-02	Mainline Contactor, 24 V Size D (optional)
21	86737-10	Contact Block, Aux. (used with Mainline Contactor)
22	PA7341	Fuse Block, Motor Ckt. 30A. (Optional)
	PA7342	Fuse Block, Motor Ckt. 60A. (Optional)
23*	86709-XX	Fuse, Motor Circuit (Optional) see note below
24	86736-XX	Overload Relay, Hoist (Optional) see note below
25	86736-XX	Overload Relay, Trolley (Optional) see note below
26	86715-017	ACM, S.S., 1 H.P. Max. 200-230 V, 2 H.P. Max 460 V
	86715-019	ACM, S.S., 2.5 H.P. Max. 200-230 V, 5 H.P. Max 460 V
	86715-018	ACM, 2S., 1 H.P. Max. 200-230 V, 2 H.P. Max 460 V
	86715-020	ACM, 2S., 2.5 H.P. Max. 200-230 V, 5 H.P. Max 460 V
	86715-002	ACM, S.S., 2 H.P. Max. 575 V
	86715-004	ACM, S.S., 5 H.P. Max. 575 V
	86715-006	ACM, 2S., 2 H.P. Max. 575 V
	86715-008	ACM, 2S., 5 H.P. Max. 575 V
Not Shown	69505-02	Danger Label, Electrical

*Recommended Spare Parts

NOTE:

When ordering Motor Circuit Fuses or Overload Relays, provide as much information about the hoist as possible. Hoist serial number, motor H.P.'s, full load currents, supply voltage, etc. ACM's listed are for 115 V control only, for 24 V order by description.

PARTS LIST - PRODUCT SERIES 34

PENDANT CONTROL STATION

PENDANT CONTROL STATION PARTS LIST

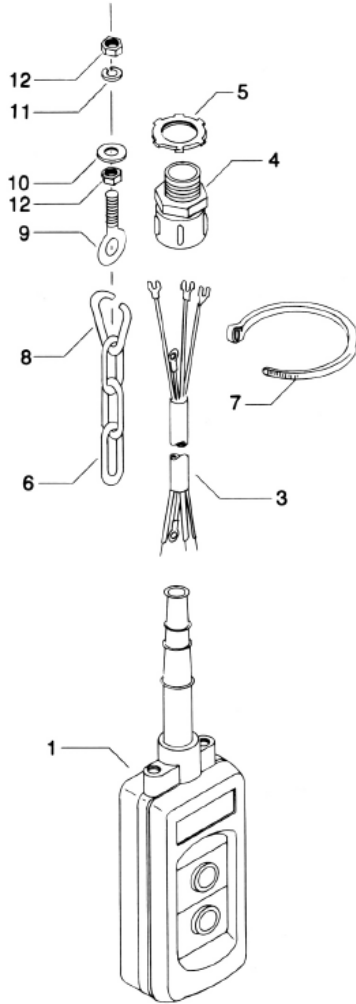

PUSHBUTTON STATION

ITEM NO.	PART NUMBER	DESCRIPTION
1	68898-01	2-Button, Single Speed Pushbutton Station Assembly
	68898-02	2-Button, Two Speed Pushbutton Station Assembly
	86718-02	4-Button, Pushbutton Station, Enclosure only
	86718-03	6-Button, Pushbutton Station Enclosure only
2	86718-04	8-Button, Pushbutton Station Enclosure only
	86718-16	Single Speed Contact Block (not shown)
	86718-19	Two Speed Contact Block (not shown)
	86718-05	Operator Button (Black)
	86718-06	Operator Button (Green)
3	86718-07	Operator Button (Red)
	62046	Cable, 16 Awg., 4 Cond.
	PA2513	Cable, 16 Awg., 8 Cond.
4	PA2514	Cable, 16 Awg., 14 Cond.
	PA2427	Cable Grip, 4 Cond. Cable
	PA2145	Cable Grip, 8 Cond. Cable
5	PA2517	Cable Grip, 14 Cond. Cable
	PA1827	Locknut for PA2427 & PA2145
	PA2036	Locknut for PA2517
6	PA2034	Strain Relief Chain
7	PA6750	Self-Locking Tie
8	PA2035	Chain Repair Link
9	PA5037	Eye Bolt
10	15-4-2C	Washer
11	17-4C	Lockwasher
12	22-4C	Nut
13	63178-01	Warning Label

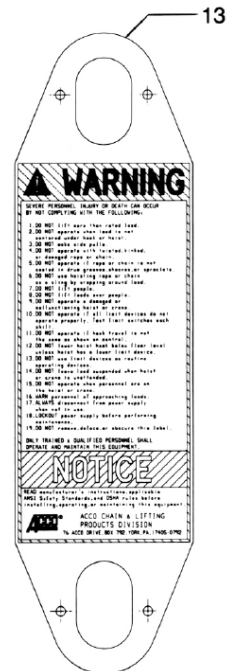

**WARNING LABEL
63178-01
Replace Label
If Lost or Illegible**

NOTE:

When ordering pushbutton control cable or strain relief chain, specify length in feet. When specifying length of control cable, allow sufficient length to make connections inside of pushbutton station and control enclosure.

PARTS LIST - PRODUCT SERIES 34

PENDANT CONTROL STATION

PENDANT CONTROL STATION PARTS LIST

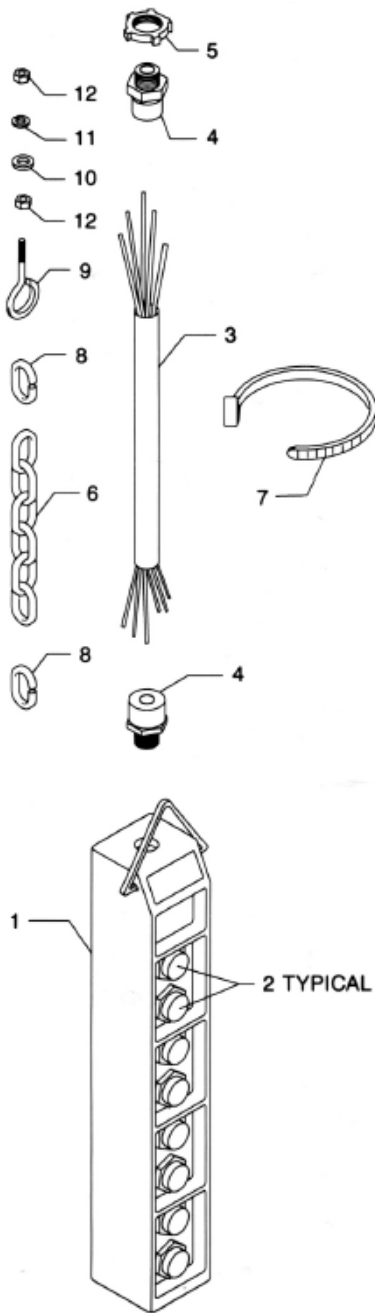

PUSHBUTTON STATION

ITEM NO.	PART NUMBER	DESCRIPTION
1	86716-01	2-Button Enclosure
	86716-02	4-Button Enclosure
	86716-03	6-Button Enclosure
	86716-04	8-Button Enclosure
	86716-05	10-Button Enclosure
2	86716-06	Single Speed Button Assy.
	86716-07	Two Speed Button Assy.
	86716-08	Three Speed Button Assy.
	86716-09	Five Speed Button Assy.
	86716-10	On Button (Green)
	86716-11	Off Button (Red)
	86716-12	Pilot Light (Red)
	86716-13	Two Position Maint. Selector Switch
	86716-14	Three Position Maint. Selector Switch
	86716-15	Push - Pull Operator (Maint.)
	86716-16	Red Mushroom Head Operator (Momentary)
86716-17	Two Position Keylock Selector (Maint.)	
86716-18	2-Button Maint. Operator (Interlocked)	
86716-19	Contact Block (1 N.O. & 1 N.C.)	
86716-20	Closing Button (For Unused Holes)	
86716-21	P. B. Operator (Black, 1 N.O. & 1 N.C.)	
3	62046	Cable, 16 AWG., 4 Cond.
	PA2513	Cable, 16 AWG. 8 Cond.
	PA2514	Cable, 16 AWG., 14 Cond.
	PA6706	Cable, 16 AWG., 24 Cond.
4	PA2427	Cable Grip, 4 Cond. Cable
	PA6652	Cable Grip, 8 Cond. Cable
	PA2517	Cable Grip, 14 Cond. Cable
	PA6705	Cable Grip, 24 Cond. Cable
5	PA1827	Locknut for PA2427 & PA6652
	PA2036	Locknut for PA2517
	PA1828	Locknut for PA6705
6	PA2034	Strain Relief Chain
7	PA6750	Self-Locking Tie
8	PA2035	Chain Repair Link
9	PA5037	Eye Bolt
10	15-4-2C	Washer
11	17-4C	Lockwasher
12	22-4C	Nut
13	63178-01	Warning Label



**WARNING LABEL
63178-01
Replace Label
If Lost or Illegible**

NOTE: When ordering pushbutton control cable or strain relief chain, specify length in feet. When specifying length of control cable, allow sufficient length to make connections inside of pushbutton station and control enclosure.

PARTS LIST - PRODUCT SERIES 34

2-WHEEL PLAIN TROLLEY ASSEMBLY 6 IN. DIAMETER WHEEL - NON-SWIVELING - TWO MOUNTING STUDS

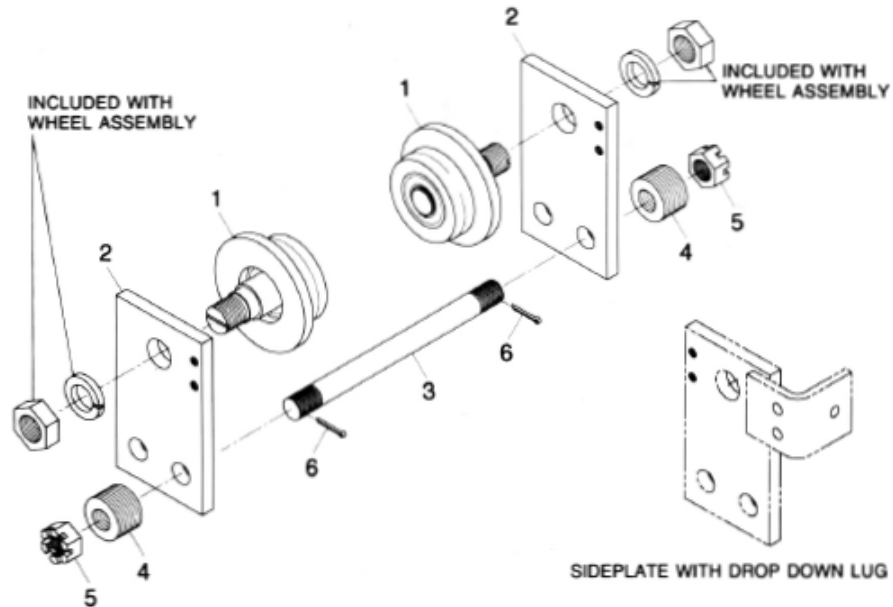

TROLLEY PARTS - 6" DIAMETER WHEELS

TROLLEY ASSEMBLY	BEAM FLANGE WIDTH (Inches)	DROP DOWN LUGS	WHEEL ASSEMBLY		SIDEPLATE	SIDEPLATE	STUD	WASHER		NUT	COTTER PIN						
			2 PER TROLLEY		1 PER TROLLEY	1 PER TROLLEY	2 PER TROLLEY			4 PER TROLLEY	4 PER TROLLEY						
			MATL.	ITEM 1	ITEM 2	ITEM 2	ITEM 3	QTY/TRLY	ITEM 4	ITEM 5	ITEM 6						
69988-01	4-1/2 to 5	No	Steel Dual Tread	68974-01	69986-01	69986-01	69766-04	36	A210-03	26-20	PA1355						
69988-02	5-1/8 to 8						69766-05	76									
69988-03	8-1/8 to 10-1/2						69987-01	69987-01				69766-06	40				
69988-17	10-5/8 to 12-1/2						69987-04	69987-04				69766-07					
69988-18	12-5/8 to 14						69987-07	69987-07				69766-08					
69988-04	4-1/2 to 5						Bronze Dual Tread	69974-02				69986-01	69986-01	69766-04	36		
69988-05	5-1/8 to 8													69766-05	76		
69988-06	8-1/8 to 10-1/2													69987-01	69987-01	69766-06	40
69988-19	10-5/8 to 12-1/2													69987-04	69987-04	69766-07	
69988-20	12-5/8 to 14													69987-07	69987-07	69766-08	
69988-07	4-1/2 to 5	Steel Dual Tread	69974-01	69986-02	69986-03	69766-04			36								
69988-08	5-1/8 to 8					69766-05			76								
69988-09	8-1/8 to 10-1/2					69987-02			69987-03	69766-06	40						
69988-21	10-5/8 to 12-1/2					69987-05			69987-06	69766-07							
69988-22	12-5/8 to 14					69987-08			69987-09	69766-08							
69988-10	4-1/2 to 5					Bronze Dual Tread	69974-02	69986-02	69986-03	69766-04	36						
69988-11	5-1/8 to 8									69766-05	76						
69988-12	8-1/8 to 10-1/2									69987-02	69987-03	69766-06	40				
69988-23	10-5/8 to 12-1/2									69987-05	69987-06	69766-07					
69988-24	12-5/8 to 14									69987-08	69987-09	69766-08					
69988-13	3-1/4 to 5 (a)	No	Steel Flat	69976-01	69986-01					69986-01							
69988-14	3-1/4 to 5 (a)		Bronze Flat	69976-02													
69988-15	3-1/4 to 5 (a)		Steel Flat	69976-01													
69988-16	3-1/4 to 5 (a)	Yes	Bronze Flat	69976-02	69986-02					69986-03	69766-04	36					

No Recommended Spare Parts

NOTE: (a) For operation on patented monorail track.

PARTS LIST - PRODUCT SERIES 34

4-WHEEL PLAIN TROLLEY ASSEMBLY 6 IN. DIAMETER WHEEL - NON-SWIVELING - ONE MOUNTING STUD

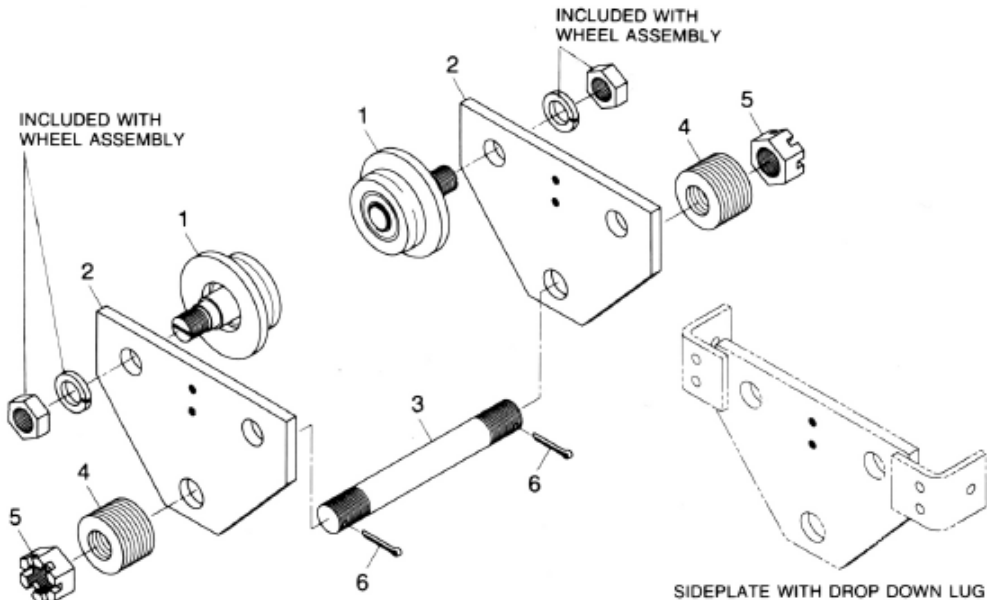

TROLLEY PARTS - 6" DIAMETER WHEELS

TROLLEY ASSEMBLY	BEAM FLANGE WIDTH (Inches)	DROP DOWN LUGS	WHEEL ASSEMBLY		SIDEPLATE	STUD	WASHER		NUT	COTTER PIN		
			4 PER TROLLEY				ITEM 4	ITEM 5				
			MATL.	ITEM 1	ITEM 2	ITEM 3			QTY/TRLY	ITEM 6		
69993-01	4-1/2 to 5	No	Steel Dual Tread	69974-01	SIDEPLATE	STUD	WASHER	NUT	COTTER PIN			
69993-02	5-1/8 to 8									69979-01	69768-04	16
69993-03	8-1/8 to 10-1/2									69980-01	69768-05	18
69993-17	10-5/8 to 12-1/2									69981-01	69768-06	20
69993-18	12-5/8 to 14									69981-03	69768-07	
69993-04	4-1/2 to 5		Bronze Dual Tread	69974-02						69979-01	69768-04	16
69993-05	5-1/8 to 8									69980-01	69768-05	18
69993-06	8-1/8 to 10-1/2									69981-01	69768-06	20
69993-19	10-5/8 to 12-1/2									69981-03	69768-07	
69993-20	12-5/8 to 14									69981-05	69768-08	
69993-07	4-1/2 to 5	Yes	Steel Dual Tread	69974-01	69979-02	69768-04	16	PA5167	26-32	PA3796		
69993-08	5-1/8 to 8				69980-02	69768-05	18					
69993-09	8-1/8 to 10-1/2				69981-02	69768-06	20					
69993-21	10-5/8 to 12-1/2				69981-04	69768-07						
69993-22	12-5/8 to 14				69981-06	69768-08						
69993-10	4-1/2 to 5		Bronze Dual Tread	69974-02	69979-02	69768-04	16					
69993-11	5-1/8 to 8				69980-02	69768-05	18					
69993-12	8-1/8 to 10-1/2				69981-02	69768-06	20					
69993-23	10-5/8 to 12-1/2				69981-04	69768-07						
69993-24	12-5/8 to 14				69981-06	69768-08						
69993-13	3-1/4 to 5 (a)	No	Steel Flat	69976-01	SIDEPLATE	STUD	WASHER	NUT	COTTER PIN			
69993-14	3-1/4 to 5 (a)		Bronze Flat	69976-02						69979-01	69768-04	16
69993-15	3-1/4 to 5 (a)	Yes	Steel Flat	69976-01	69979-02	69768-04	16	26-32	PA3796			
69993-16	3-1/4 to 5 (a)		Bronze Flat	69976-02								

No Recommended Spare Parts

NOTE: (a) For operation on patented monorail track.

PARTS LIST - PRODUCT SERIES 34

4-WHEEL GEARED TROLLEY ASSEMBLY 6 IN. DIAMETER WHEEL - NON-SWIVELING - ONE MOUNTING STUD

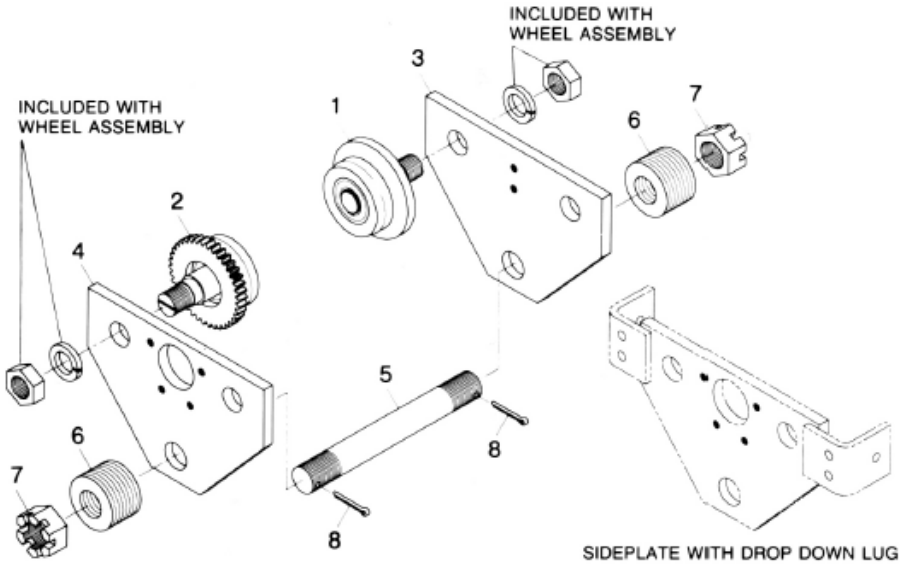

TROLLEY PARTS - 6" DIAMETER WHEELS

TROLLEY ASSEMBLY	BEAM FLANGE WIDTH (Inches)	DROP DOWN LUGS	WHEEL ASSEMBLY			SIDEPLATE	SIDEPLATE	STUD	WASHER		NUT	COTTER PIN
			2 EACH PER TROLLEY			1 PER TROLLEY	1 PER TROLLEY	1 PER TROLLEY			2 PER TROLLEY	2 PER TROLLEY
			MATL.	PLAIN ITEM 1	GEARED ITEM 2	ITEM 3	ITEM 4	ITEM 5	QTY/TRLY	ITEM 6	ITEM 7	ITEM 8
69994-01	4-1/2 to 5	No	Steel Dual Tread	69974-01	69975-01	69979-01	69982-01	69768-04	16	PA5167	26-32	PA3796
69994-02	5-1/8 to 8					69980-01	69983-01	69768-05	18			
69994-03	8-1/8 to 10-1/2					69981-01	69984-01	69768-06	20			
69994-17	10-5/8 to 12-1/2					69981-03	69984-03	69768-07				
69994-18	12-5/8 to 14					69981-05	69984-05	69768-08				
69994-04	4-1/2 to 5		Bronze Dual Tread	69974-02	69975-02	69979-01	69982-01	69768-04	16			
69994-05	5-1/8 to 8					69980-01	69983-01	69768-05	18			
69994-06	8-1/8 to 10-1/2					69981-01	69984-01	69768-06	20			
69994-19	10-5/8 to 12-1/2					69981-03	69984-03	69768-07				
69994-20	12-5/8 to 14					69981-05	69984-05	69768-08				
69994-07	4-1/2 to 5	Yes	Steel Dual Tread	69974-01	69975-01	69979-02	69982-02	69768-04	16			
69994-08	5-1/8 to 8					69980-02	69983-02	69768-05	18			
69994-09	8-1/8 to 10-1/2					69981-02	69984-02	69768-06	20			
69994-21	10-5/8 to 12-1/2					69981-04	69984-04	69768-07				
69994-22	12-5/8 to 14					69981-06	69984-06	69768-08				
69994-10	4-1/2 to 5		Bronze Dual Tread	69974-02	69975-02	69979-02	69982-02	69768-04	16			
69994-11	5-1/8 to 8					69980-02	69983-02	69768-05	18			
69994-12	8-1/8 to 10-1/2					69981-02	69984-02	69768-06	20			
69994-23	10-5/8 to 12-1/2					69981-04	69984-04	69768-07				
69994-24	12-5/8 to 14					69981-06	69984-06	69768-08				
69994-13	3-1/4 to 5 (a)	No	Steel Flat	69976-01	69977-01	69979-01	69982-01	69768-04	16			
69994-14	3-1/4 to 5 (a)		Bronze Flat	69976-02	69977-02							
69994-15	3-1/4 to 5 (a)	Yes	Steel Flat	69976-01	69977-01	69979-02	69982-02	69768-04				
69994-16	3-1/4 to 5 (a)		Bronze Flat	69976-02	69977-02							

No Recommended Spare Parts

NOTE: (a) For operation on patented monorail track.

PARTS LIST - PRODUCT SERIES 34

4-WHEEL GEARED TROLLEY ASSEMBLY DUAL DRIVE 6 IN. DIAMETER WHEEL - NON-SWIVELING - ONE MOUNTING STUD

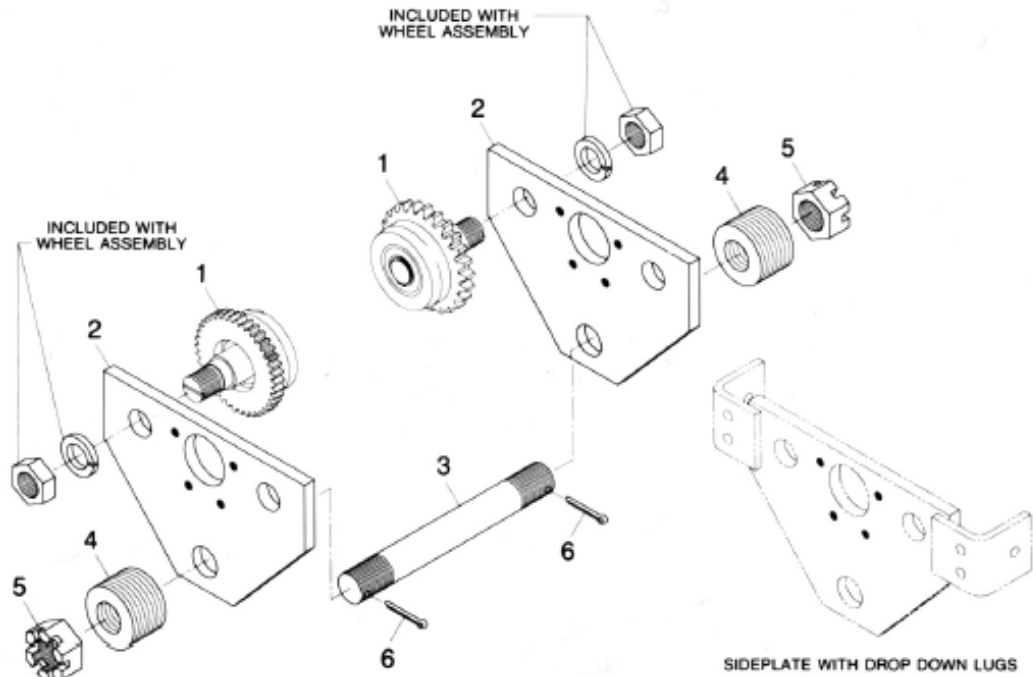

TROLLEY PARTS - 6" DIAMETER WHEELS

TROLLEY ASSEMBLY	BEAM FLANGE WIDTH (Inches)	DROP DOWN LUGS	WHEEL ASSEMBLY		SIDEPLATE	STUD	WASHER		NUT	COTTER PIN
			4 PER TROLLEY		2 PER TROLLEY	1PER TROLLEY			2 PER TROLLEY	2 PER TROLLEY
			MATL.	ITEM 1	ITEM 2	ITEM 3	QTY/TRLY	ITEM 4	ITEM 5	ITEM 6
69997-01	4-1/2 to 5	No	Steel Dual Tread	69975-01	69982-01	69768-04	16	PA5167	26-32	PA3796
69997-02	5-1/8 to 8				69983-01	69768-05	18			
69997-03	8-1/8 to 10-1/2				69984-01	69768-06	20			
69997-17	10-5/8 to 12-1/2				69984-03	69768-07				
69997-18	12-5/8 to 14				69984-05	69768-08				
69997-04	4-1/2 to 5		Bronze Dual Tread	69975-02	69982-01	69768-04	16			
69997-05	5-1/8 to 8				69983-01	69768-05	18			
69997-06	8-1/8 to 10-1/2				69984-01	69768-06	20			
69997-19	10-5/8 to 12-1/2				69984-03	69768-07				
69997-20	12-5/8 to 14				69984-05	69768-08				
69997-07	4-1/2 to 5	Yes	Steel Dual Tread	69975-01	69982-02	69768-04	16			
69997-08	5-1/8 to 8				69983-02	69768-05	18			
69997-09	8-1/8 to 10-1/2				69984-02	69768-06	20			
69997-21	10-5/8 to 12-1/2				69984-04	69768-07				
69997-22	12-5/8 to 14		69984-06	69768-08						
69997-10	4-1/2 to 5		Bronze Dual Tread	69975-02	69982-02	69768-04	16			
69997-11	5-1/8 to 8				69983-02	69768-05	18			
69997-12	8-1/8 to 10-1/2				69984-02	69768-06	20			
69997-23	10-5/8 to 12-1/2	69984-04			69768-07					
69997-24	12-5/8 to 14	69984-06	69768-08							
69997-13	3-1/4 to 5 (a)	No	Steel Flat	69977-01	69982-01	69768-04	16			
69997-14	3-1/4 to 5 (a)		Bronze Flat	69977-02						
69997-15	3-1/4 to 5 (a)	Yes	Steel Flat	69977-01						
69997-16	3-1/4 to 5 (a)		Bronze Flat	69977-02	69982-02					

No Recommended Spare Parts

NOTE: (a) For operation on patented monorail track.

PARTS LIST - PRODUCT SERIES 34

LOADBAR ASSEMBLY - FOR RIGID TROLLEYS

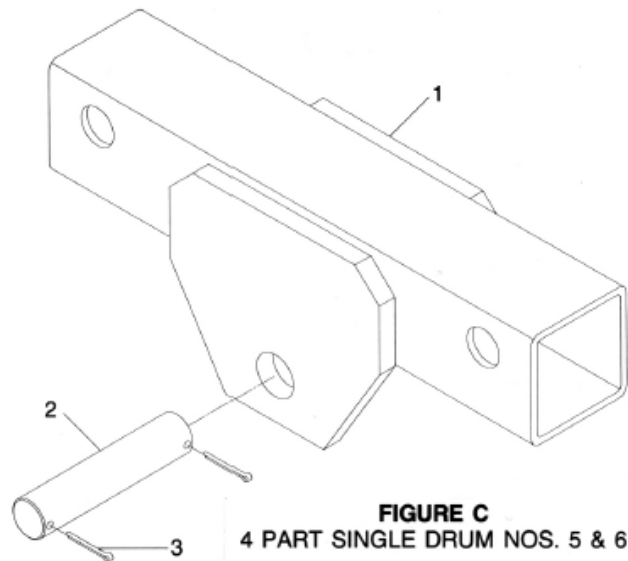
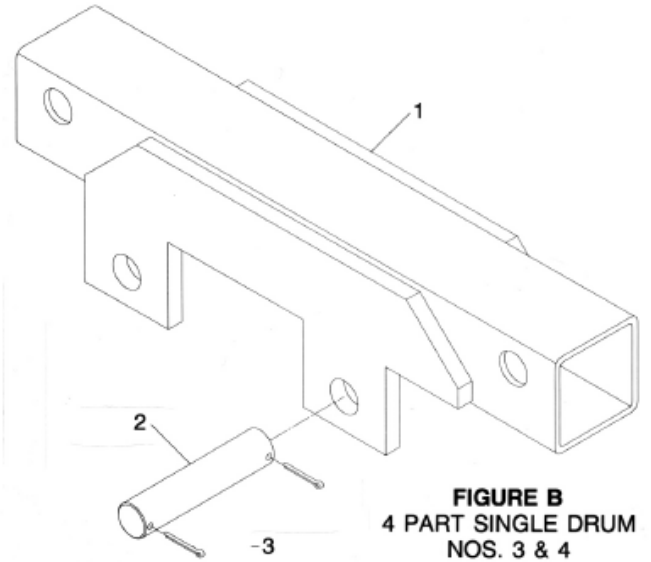
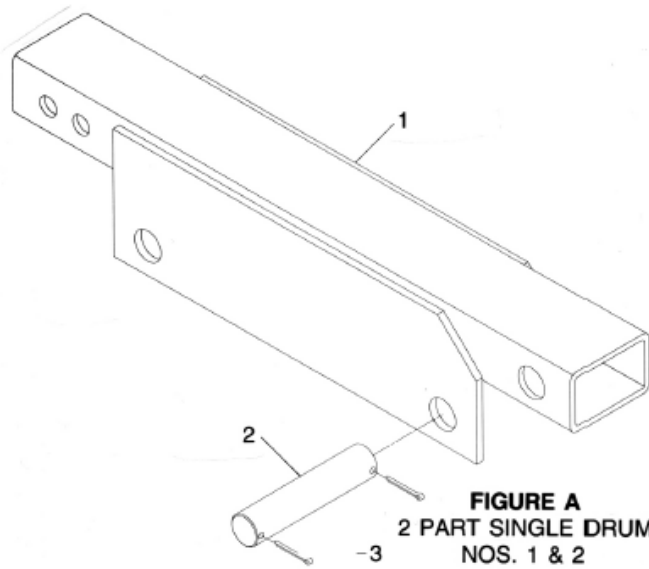

LOADBAR PARTS

ITEM NO.	PART NO.	DESCRIPTION	QTY.
1	70219-01	Loadbar, 2PS, Drum No. 1	1
	70219-02	Loadbar, 2PS, Drum No. 2	
	70168-03	Loadbar, 4PS, Drum No. 3	
	70168-04	Loadbar, 4PS, Drum No. 4	
	70166	Loadbar, 4PS, Drum No. 5	
	70166	Loadbar, 4PS, Drum No. 6	
2	70185	Pin, 2PS, Drum Nos. 1 & 2 Pin, 4PS, Drum Nos. 3 & 4	2
2	70164	Pin, 4PS, Drum Nos. 5 & 6	1
3	PA3796	Cotter Pin	(a)

No Recommended Spare Parts

NOTE:

(a) Quantity of 4 required when 2 pins are used, and quantity of 2 required when 1 pin is used.

PARTS LIST - PRODUCT SERIES 34

HAND-GEARED TROLLEY DRIVE

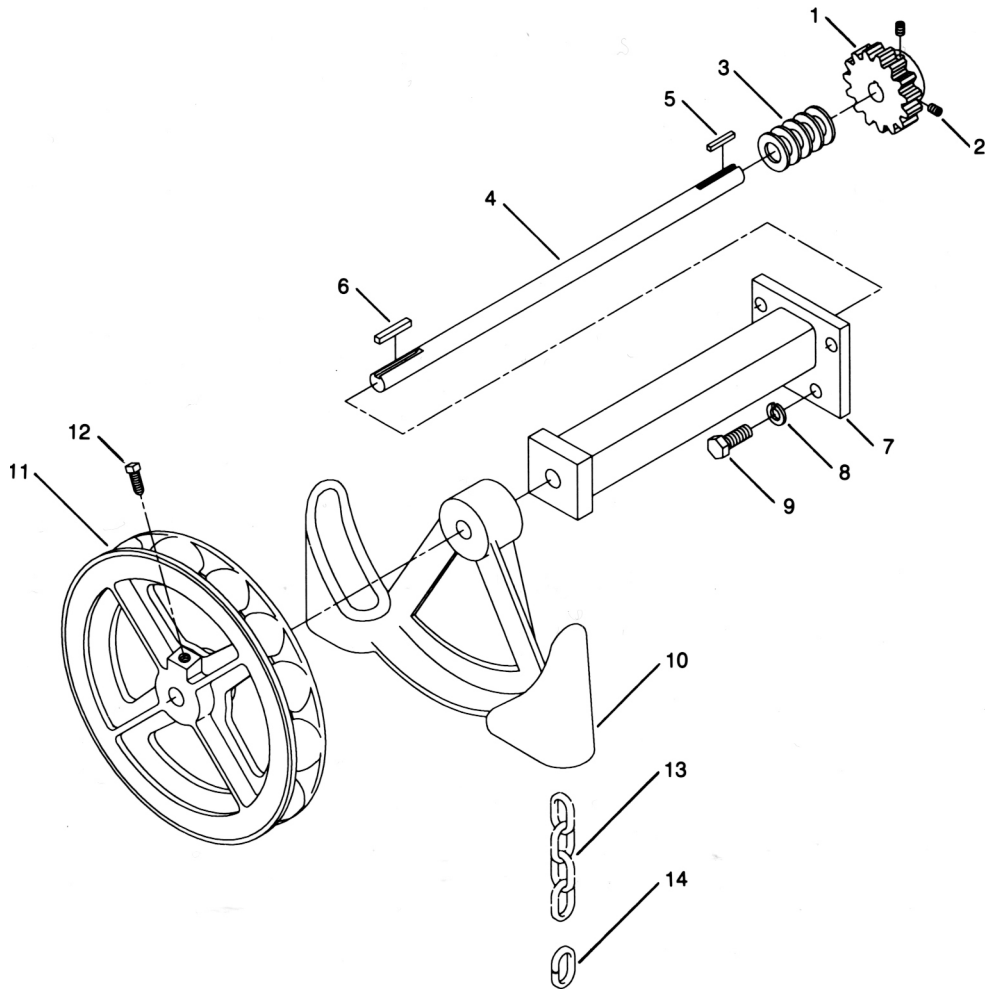

HAND-GEARED TROLLEY DRIVE PARTS

ITEM NO.	PART NUMBER	DESCRIPTION	QTY
1	69788	Pinion 15T	1
2	12-5-4	Set Screw 5/16-18x1/4	2
3	15-12-1C	Washer	5
4	69798-02	Shaft	1
5	52674	Key 3/16 Sq.x1-1/4	1
6	PA6956	Key 1/4 Sq.x1-5/8	1
7	69803-02	Bearing	1

ITEM NO.	PART NUMBER	DESCRIPTION	QTY
8	17-8C	Lockwasher 1/2	4
9	35-8-20C	Bolt 1/2-13x1-1/4	4
10	B2143-1	Hand Chain Guide	1
11	B464-4	Handwheel	1
12	14-6-16	Set Screw	1
13	(a)	Hand Chain	1
14	(a)	Open Link	1

No Recommended Spare Parts

NOTES:

- (a) When ordering hand chain, order Part Number (see below) and specify length.
- (b) Federal Specification QQ-Z-325, Type I, Class 3.
- (c) Federal Specification QQ-Z-325, Type I, Class 2.

TYPE OF TROLLEY	CHAIN MATERIAL	HANDCHAIN	OPEN LINK
Steel Wheels	Steel, Zinc Electro Plated (Acco Std) (b)	48158-1	60252-01
Steel Wheels	Steel, Zinc Electro Plated (c)	48158-11	60252-11
Bronze Wheels	Aluminum	48159-1	PA3985

**THIS PAGE INTENTIONALLY
LEFT BLANK**

PARTS LIST - PRODUCT SERIES 34

MOTORIZED TROLLEY DRIVE

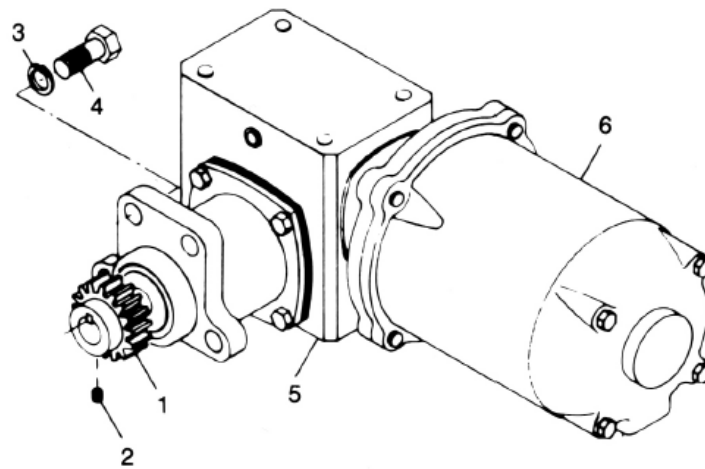

MOTORIZED TROLLEY DRIVE PARTS

ITEM NO.	PART NO.	DESCRIPTION	MONORAIL TROLLEY QUANTITY	TOP RUNNING TROLLEY QUANTITY
1	69788	Pinion (15 teeth)	1	0
	62214	Pinion (14 teeth)	0	1
2	12-5-4	Set Screw	2	0
	12-4-4C	Set Screw	0	2
3	17-8C	Lockwasher	4	4
4	35-8-20C	Hex Head Bolt	4	4
5	(a)	Right-Angle Gear Reducer	1	1
6	(b)	Motor	1	1
Not Shown	69807	EP Moly D Grease	(c)	(c)

No Recommended Spare Parts

NOTES:

(a) Select right-angle gear reducer as specified from the following:

- Part No. 71056-4X, 20:1 Reduction, 50 FPM Monorail Trolley or 32 FPM Top-Running Trolley, (standard).
- Part No. 71056-2X, 10:1 Reduction, 100 FPM Monorail Trolley or 65 FPM Top-Running Trolley, (standard).
- Part No. 71056-0X, 5:1 Reduction, 125 FPM Top-Running Trolley, (standard).
- Part No. 71056-5X, 30:1 Reduction, 33 FPM Monorail Trolley, (non-standard).
- Part No. 71056-3X, 15:1 Reduction, 65 FPM Monorail Trolley, (non-standard).
- Part No. 71056-1X, 7.5:1 Reduction, 125 FPM Monorail Trolley, (non-standard).

X = Reducer Mounting Position Number 1, 2, 3 or 4. See Serial Record for position used. Complete the part number by inserting the position number in place of the 'X'.

(b) Trolley motor brake is optional on motorized right-angle gear reducer trolley drive. Motors for monorail trolley drive without motor brake have one shaft extension. Motors for monorail trolley drive with motor brake have two shaft extensions. Motors for top-running trolley drive with or without motor brake have one shaft extension. Select motor as specified from the following:

PART NO. MOTOR WITH ONE SHAFT EXT.	PART NO. MOTOR WITH TWO SHAFT EXT.	VOLTAGE	HP	RPM	SPEED	FRAME
61010-01	65818-04	200	1/2	1800	Single	56C
61010-02	65818-05	208/230/460				
61010-03	65818-06	575				
61010-04	65818-10	200	1			
61010-05	65818-11	208/230/460				
61010-06	65818-12	575				
61012-01	65819-01	200	1/2 / 116	1800/600	Two	
61012-02	65819-02	230				
61012-03	65819-03	460				
61012-04	65819-04	575				
61012-05	65819-09	200	1 / 113			
61012-06	65819-10	230				
61012-07	65819-11	460				
61012-08	65819-12	575				

For other specified special motors, refer to additional information pages supplied with manual.

(c) Exposed gears and pinions on trolleys are shipped from the factory without lubricant. Lyondell® EP Moly D Grease, packaged in a 4-ounce bottle, is furnished with all hoists that have trolleys specified. Refer to LUBRICATION section of Manual 69833: Installation, Operation, and Maintenance Manual for WRIGHT® WORK-RATED® Wire Rope Electric Hoists. Additional containers of Lyondell® EP Moly D Grease, packaged in a 4-ounce bottle, can be obtained by ordering Acco® part no. 69807.

PARTS LIST - PRODUCT SERIES 34

MOTORIZED TROLLEY RIGHT-ANGLE GEAR REDUCER

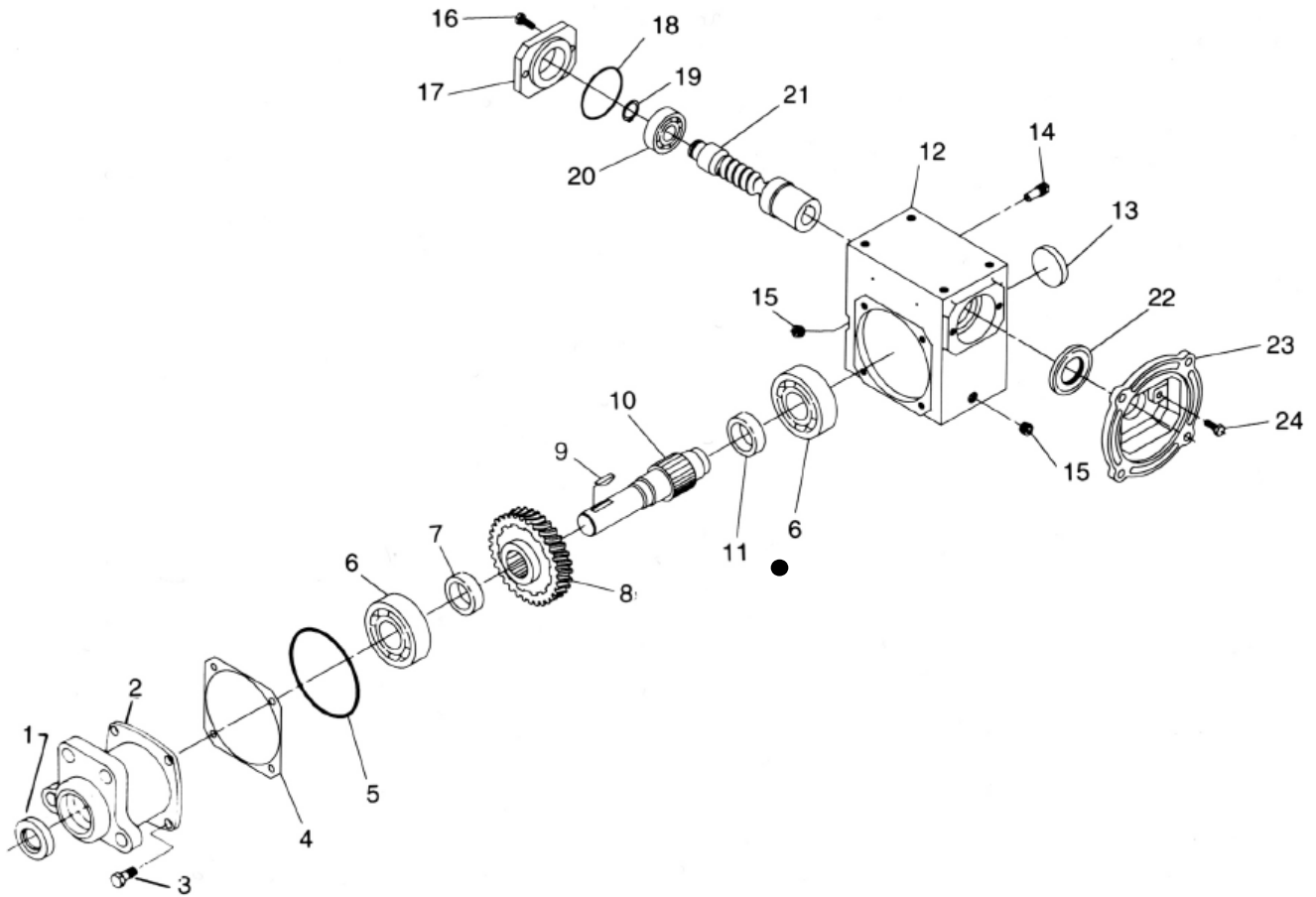

RIGHT-ANGLE GEAR REDUCER PARTS

ITEM NO.	PART NUMBER	DESCRIPTION	QTY/ ASSY
1	V93216A	Oil Seal	1*
2	V28631C	Adapter	1
3	V91012A	Hex Head Cap Screw	4
4	VZ17T	Output Cover Shim	AR
5	V95769A	O-Ring	1
6	V40831	Output Bearing, Cone	2
	V40832	Output Bearing, Cup	2
7	VY17SG	Gear Spacer	1
8	VG17S05	Worm Gear 5:1	1
	VG17S07	Worm Gear 7.5:1	
	VG17S10	Worm Gear 10:1	
	VG17S15	Worm Gear 15:1	
	VG17S20	Worm Gear 20:1	
	VG17S30	Worm Gear 30:1	
9	V40267	Woodruff Key	1
10	VS17SGX01	Output Shaft	1
11	VY17SG	Gear Spacer	1
12	VH17SG	Gear Housing	1

ITEM NO.	PART NUMBER	DESCRIPTION	QTY/ ASSY
13	V93224A	Expansion Plug	1
14	V41752	Vent Plug	1
15	V40411	Pipe Plug	4
16	V91012A	Hex Head Cap Screw	2
17	VC13NB	Input Cover	1
18	V95771A	O-Ring	1
19	V41050	Retaining Ring	1
20	V40257	Input Bearing	1
21	V36086B	Quill Input Shaft 5:1	1
	V36530B	Quill Input Shaft 7.5:1	
	V36087B	Quill Input Shaft 10:1	
	V36088B	Quill Input Shaft 15:1	
	V36089B	Quill Input Shaft 20:1	
	V36091B	Quill Input Shaft 30:1	
22	V93212A	Oil Seal	1*
23	VF13Q56	Quill Motor Flange	1
24	V91012A	Hex Head Cap Screw	2

*Recommended Spare Parts

NOTE:

Approximate capacity of oil bath is 1 pint. Refer to Lubrication section of Manual 69834.

PARTS LIST - PRODUCT SERIES 34

TROLLEY MOTOR BRAKE ASSEMBLY

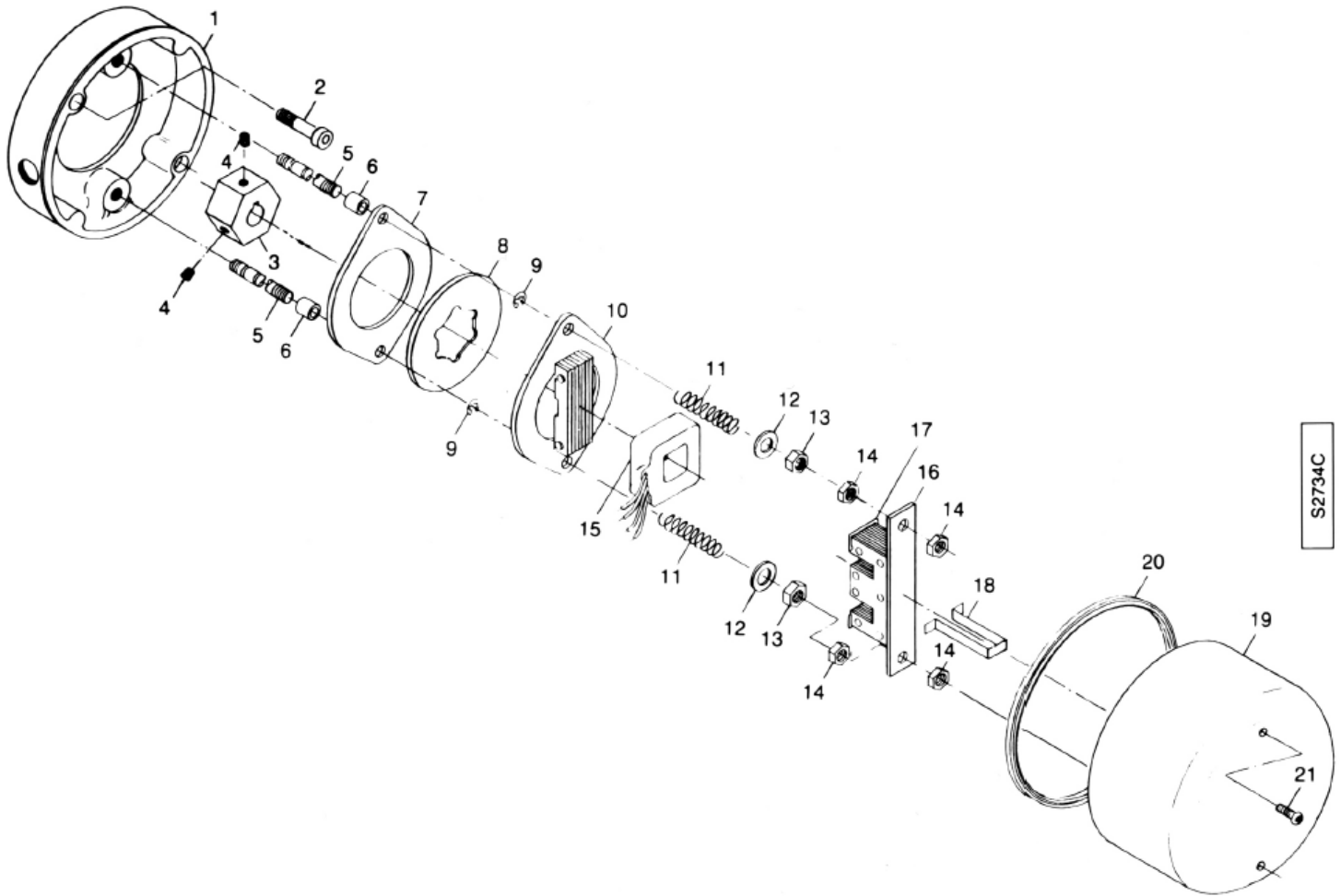

TROLLEY MOTOR BRAKE PARTS

ITEM NO.	PART NUMBER	DESCRIPTION	QTY/ ASSY
1	65653	Adapter	1
2	1-6-24	Bolt, 3/8-16 x 1-1/2 lg	2
3	65654	Hub	1
4	12-4-6	Set Screw	2
5	65655	Stud	2
6	61459	Spacer	2
7	39794	Brake Plate	1
8*	39649	Brake Lining	1
9	PA5623	Retaining Ring	2
10	39781	Pressure Unit	1
11	PA5823	Spring	2
12	15-6-1	Flat Washer	2

ITEM NO.	PART NUMBER	DESCRIPTION	QTY/ ASSY
13	PA2377	Locknut	2
14	24-6	Jam Nut, 3/8	4
15*	39783-2 39783-3 39783-6	Coil 575 VAC 230/460 VAC 208 VAC	1
16	39780	Magnet Unit	1
17	39784	Shading Coil (a)	2
18	39877	Coil Strap	1
19	69161	Brake Cover	1
20	PA7110	Gasket	1.77ft
21*	PA7323	Screw, LOC-WEL, #10-24 (b)	2

*Recommended Spare Parts

- (a) Shading Coil is furnished with Magnet Unit, but also available as a spare.
- (b) Screw with self-locking feature must be utilized. Substitutes are not permissible.
- (c) Trolley motor brake assembly shown on this page is the optional brake used on motorized right-angle gear reducer monorail trolley drives. For the optional brake used on motorized right-angle gear reducer top-running trolley drives, refer to additional information pages supplied with manual.

PARTS LIST - PRODUCT SERIES 34

DECK MOUNTED FRAME

DECK MOUNTED FRAME PARTS

ITEM NO.	DESCRIPTION	QUANTITY	PART NO.
1	End Plate, Deck Mounted Gear End	1	70224
2	End Plate, Deck Mounted Control End	1	70225
3	Frame, 2-Part Single, Drum 1 Frame, 2-Part Single, Drum 2 Frame, 2-Part Single, Drum 3 Frame, 2-Part Single, Drum 4 Frame, 2-Part Single, Drum 5 Frame, 2-Part Single, Drum 6	1	70212-01 70212-02 70253-03 70253-04 70253-05 70253-06
3	Frame, 2-Part Double, Drum 2 Frame, 2-Part Double, Drum 3 Frame, 2-Part Double, Drum 4 Frame, 2-Part Double, Drum 5 Frame, 2-Part Double, Drum 6	1	70209-02 70209-03 70209-04 70209-05 70255-06
3	Frame, 4-Part Single, Drum 3 Frame, 4-Part Single, Drum 4 Frame, 4-Part Single, Drum 5 Frame, 4-Part Single, Drum 6	1	70169-03 70169-04 70254-05 70254-06
3	Frame, 4-Part Double, Drum 4 Frame, 4-Part Double, Drum 5 Frame, 4-Part Double, Drum 6	1	70256-04 70256-05 70267-06

Note:

For part numbers of other parts shown, refer to page 9 for 2PS reeving, page 10 for 4PS reeving, page 11 for 2PD reeving, or page 12 for 4PD reeving.

No Recommended Spare Parts

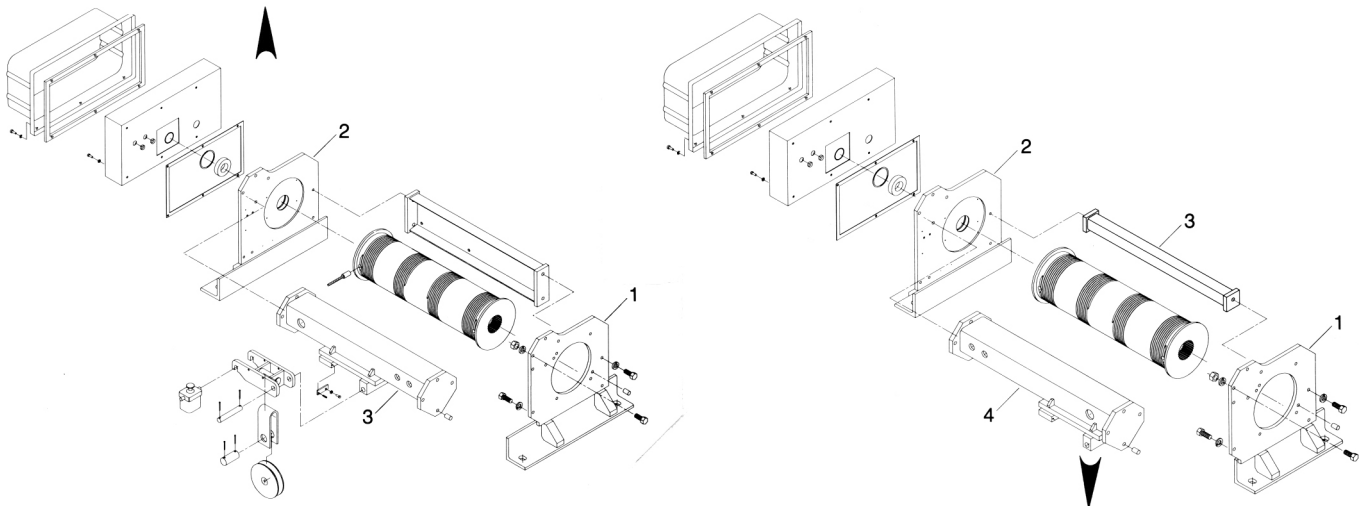

WINCH UNIT FRAME

WINCH UNIT FRAME PARTS

ITEM NO.	DESCRIPTION	QUANTITY	PART NO.
1	End Plate, Winch Gear End	1	70226
2	End Plate, Winch Control End	1	70227
3	Side Frame, Winch	1	(a)
4	Frame, Winch	1	(a)

No Recommended Spare Parts

Note:

For part numbers of other parts shown, refer to page 9 for 2PS reeving, page 10 for 4PS reeving, page 11 for 2PD reeving, or page 12 for 4PD reeving.

(a) Winch side frame part number 70210-XX and winch frame part number 70260-XX are available in various lengths. Contact Acco/Harrington or the distributor of the hoist with hoist product number and/or hoist serial number.

PARTS LIST - PRODUCT SERIES 34

TOP-RUNNING TROLLEY

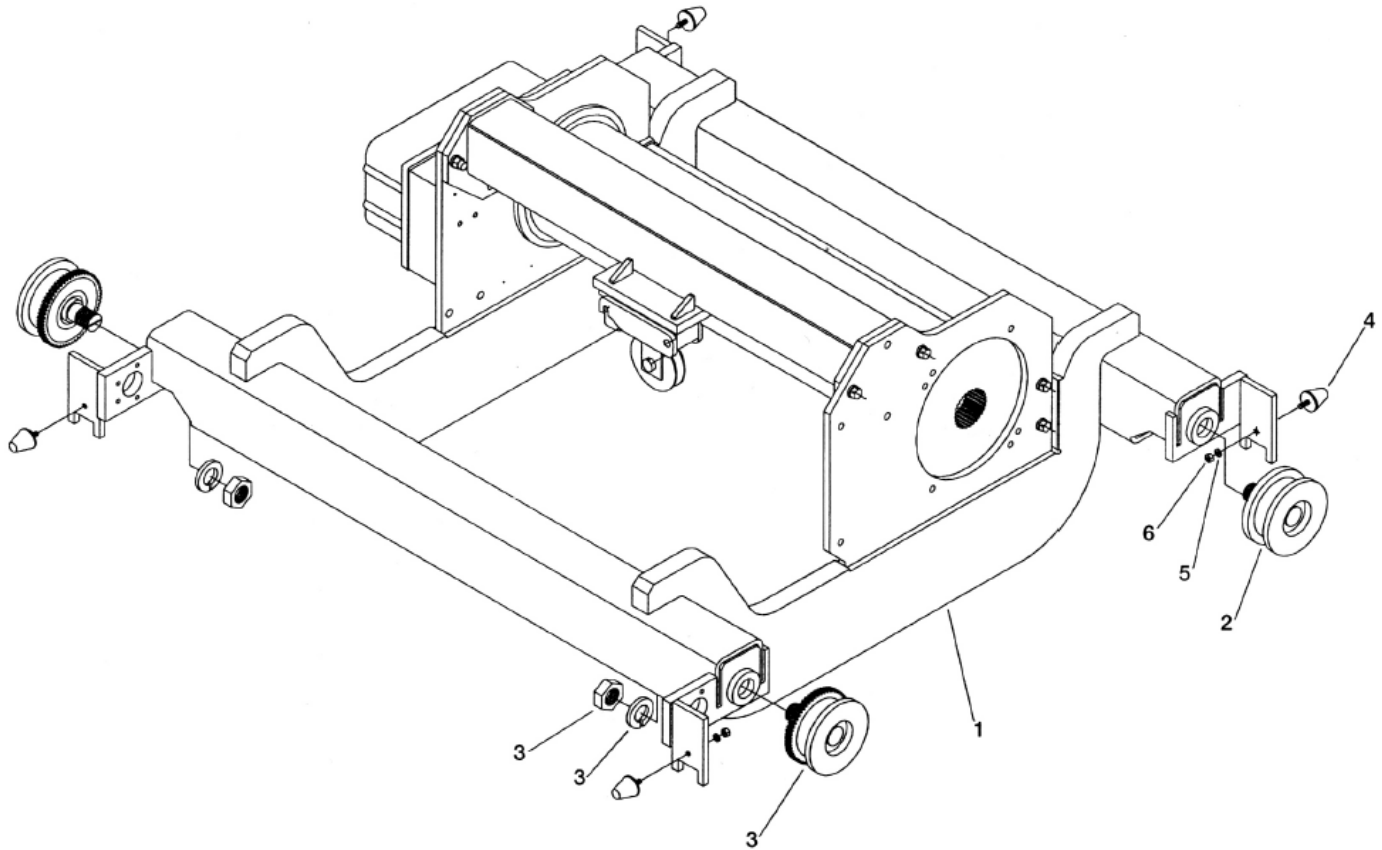

TOP-RUNNING TROLLEY FRAME PARTS

ITEM NO.	DESCRIPTION	QUANTITY	PART NO.
1	Trolley Frame, Trolley End Beams, End Plates, Gear End and Control End	1	(a)
2	Plain Wheel Assembly	2	70237-02
3	Geared Wheel Assembly	2	70237-01
4	Bumper (Optional)	4	65226
5	Lockwasher (Optional)	4	17-7
6	Nut (Optional)	4	22-7

NOTES:

For part numbers of other suspension frame parts, refer to page 10 for 4PS reeving, page 11 for 2PD reeving, or page 12 for 4PD reeving.

(a) Trolley side frame, trolley end beams, and hoist end plates are a single welded unit. Contact Acco/Harrington or the distributor of the hoist with hoist product number and/or hoist serial number; and wheel gage of trolley.

No Recommended Spare Parts

PARTS LIST - PRODUCT SERIES 34

LOADBAR ASSEMBLY - FOR SWIVELING TROLLEYS

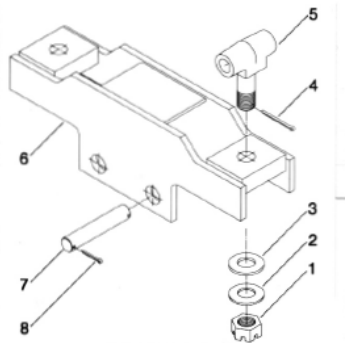

FIGURE A

2 PART SINGLE DRUM NO. 1

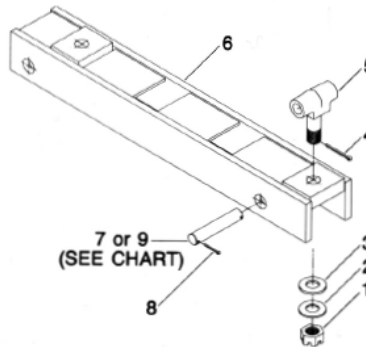

FIGURE B

2 PART SINGLE DRUM NOS. 2, 3, 4, 5, 6

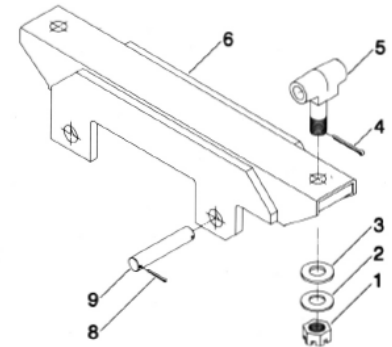

FIGURE C

4 PART SINGLE DRUM NOS. 3, 4

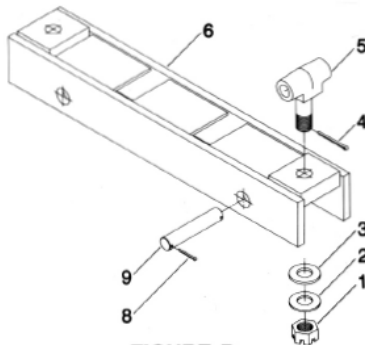

FIGURE D

4 PART DOUBLE DRUM NOS. 4, 5, 6

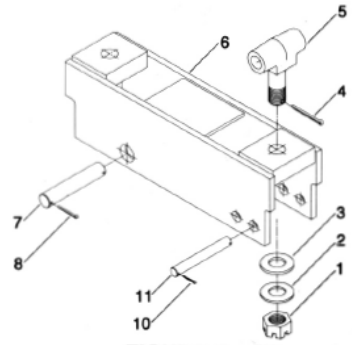

FIGURE E

2 PART DOUBLE DRUM NO. 2

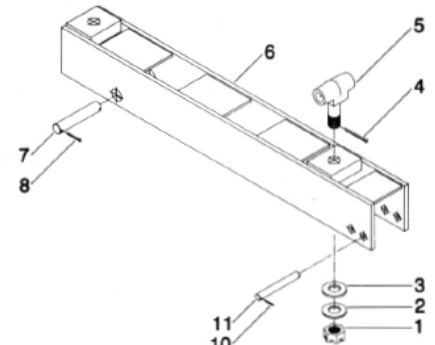

FIGURE F

2 PART DOUBLE DRUM NOS. 3, 4, 5, 6

LOADBAR PARTS

REFER TO FIGURE		A, B (DRUM 2)		B (DRUMS 3, 4, 5, 6), C, D		E, F	
ITEM NO.	DESCRIPTION	PART NUMBER	QTY	PART NUMBER	QTY	PART NUMBER	QTY
1	Hex Slotted Nut	26-28	2	26-28	2	26-28	2
2	Thrust Washer	A4421	2	A4421	2	A4421	2
3	Thrust Bearing	A4420	2	A4420	2	A4420	2
4	Cotter Pin	PA1484	2	PA1484	2	PA1484	2
5	Suspension Stud	63161	2	63161	2	63161	2
6	Loadbar	(a) (b)	1	(a) (b)	1	(a) (b)	1
7	Pin	63029-05	2	-	-	63029-05	1
8	Cotter Pin	PA1484	4	PA1484	4	PA1484	2
9	Pin	-	-	63029-01	2	-	-
10	Cotter Pin	-	-	-	-	PA1771	4
11	Pin	-	-	-	-	63295-03	2

No Recommended Spare Parts

NOTES:

For trolley parts, refer to pages 26, 27, and 28.

(a) Loadbar part numbers for:

FIGURE A	FIGURE B	FIGURE C	FIGURE D	FIGURE E	FIGURE F
70272-01	70273-02	70282-03	70280-04	70288-02	70286-03
	70267-03	70282-04	70280-05		70286-04
	70267-04		70280-06		70286-05
	70267-05				70286-06
	70267-06				

(b) Dash number (-03, -04, etc.) indicates corresponding hoist drum length.
Example: 70282-03 for Drum No. 3, 70282-04 for Drum No. 4, etc.

PARTS LIST - PRODUCT SERIES 34

OPTIONAL ELECTRICAL CONTROL ENCLOSURE

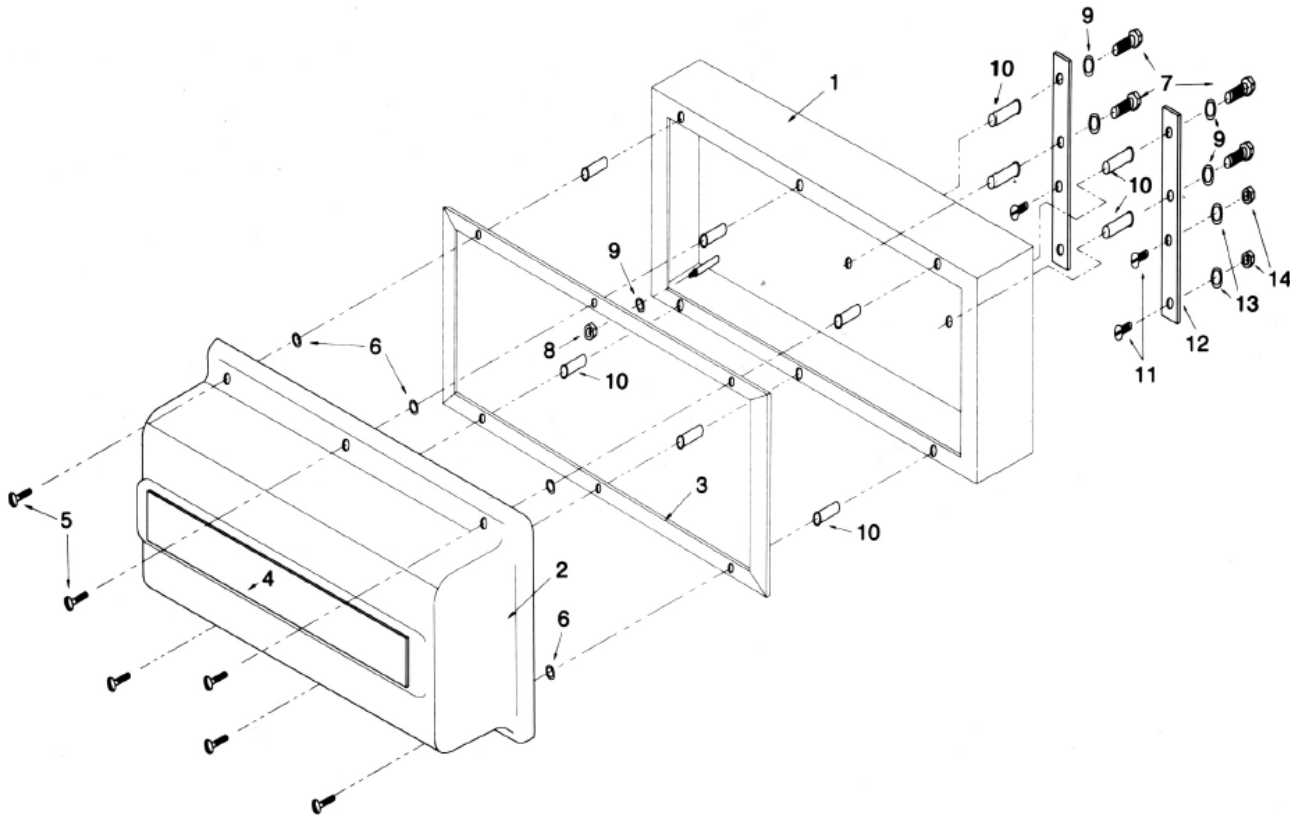

REPLACEMENT PARTS

ITEM NO.	PART NO.	DESCRIPTION	QUANTITY BY ENCLOSURE SIZE		
			11" x 21"	15" x 21"	21" x 21"
1	69829-1	Enclosure, 11 x 21	1	N/A	N/A
	69828-1	Enclosure, 15 x 21	N/A	1	N/A
	69875-1	Enclosure, 21 x 21	N/A	N/A	1
2	52823	Cover, 11 x 21	1	N/A	N/A
	52826	Cover, 15 x 21	N/A	1	N/A
	54268	Cover, 21 x 21	N/A	N/A	1
3	58531	Gasket, 11 x 21	1	N/A	N/A
	55204	Gasket, 15 x 21	N/A	1	N/A
	55206	Gasket, 21 x 21	N/A	N/A	1
4	55224-2	Label	1	1	1
5	58597	Screw, Captive	6	6	8
6	PA6634	Ring, Retaining	6	6	8
7	35-4-12	Hex Head Bolt	4	4	4
8	22-4C	Hex Nut	4	4	4
9	17-4C	Lockwasher	8	8	8
10	PA7343	Nut Insert, Closed End	10	10	12
11	5-6-20	Flathead Screw	4	4	4
12	69808	Enclosure Mounting Strap	2	2	2
13	17-6C	Lockwasher	4	4	4
14	22-6	Hex Nut	4	4	4

GENERAL CONDITIONS OF WARRANTY

Buyer must notify HHI in writing within sixty (60) days of discovery of any alleged defect, if within the applicable warranty period.

All products sold by HHI are warranted to be free from defects in material and workmanship from date of shipment by HHI for the following periods:

- 1 year – Air Powered Hoists, SNER, TNER, NER030L, and ED Electric Chain Hoists, Powered Trolleys, Powered Tiger Track Jibs and Gantries, Crane Components, Below the Hook Devices, Spare / Replacement Parts**
- 2 years – Manual Hoists & Trolleys, Beam Clamps, ACCO Wire Rope Hoists, ACCOLIFT Electric Chain Hoists, Louden and Trambeam Patented Track**
- 3 years – (N)ER2 Hoists, EQ/SEQ Hoists, (T)EM/(T)SEM hoists, and RY Hoists**
- 5 years – Manual Tiger Track Jibs and Gantries, Hoist Motor Brakes for EQ/SEQ, (T)EM/(T)SEM, and RY**
- 10 years – (N)ER2 Brake, TNER Hoist Motor Brake, Tiger Track Workstation Cranes and Monorails**

The product must be used in accordance with manufacturer's recommendations and must not have been subject to abuse, lack of maintenance, misuse, negligence, or unauthorized repairs or alterations.

Should any defect in material or workmanship occur during the above time period in any product, as determined by HHI's inspection of the product, HHI agrees, at its discretion, either to replace (not including installation) or repair the part or product free of charge. For customers in the U.S., delivery shall be made F.O.B. HHI's place of business. For international customers, delivery shall be made FCA HHI place of business, United States of America (Incoterms 2010).

No warranty claim will be honored without a valid proof of purchase. Customers must obtain a Return Goods Authorization as directed by HHI or its published repair center prior to shipping product for warranty evaluation. An explanation of the complaint must accompany the product. Product must be returned freight prepaid. Upon repair, the product will be covered for the remainder of the original warranty period. Replacement parts installed after the original warranty period will only be eligible for replacement (not including installation) for a period of one year from the installation date. If it is determined there is no defect, or that the defect resulted from causes not within the scope of HHI's warranty, the customer will be responsible for the costs of returning the product.

HHI DISCLAIMS ANY AND ALL OTHER WARRANTIES OF ANY KIND, EXPRESSED OR IMPLIED, AS TO THE PRODUCT'S MERCHANTABILITY OR FITNESS FOR A PARTICULAR PURPOSE. HHI WILL NOT BE LIABLE FOR DEATH, INJURIES TO PERSONS OR PROPERTY OR FOR INCIDENTAL, CONTINGENT, SPECIAL OR CONSEQUENTIAL DAMAGES, LOSS OR EXPENSE ARISING IN CONNECTION WITH THE USE OR MISUSE OF THE PRODUCTS, REGARDLESS OF WHETHER THE DAMAGE, LOSS OR EXPENSE RESULTS FROM ANY ACT OR FAILURE TO ACT BY HHI, WHETHER NEGLIGENT OR WILLFUL, OR FROM ANY OTHER CAUSE.



Harrington Hoists, Inc.
401 West End Avenue
Manheim, PA 17545

www.harringtonhoists.com

Toll Free: 800-233-3010
Phone: 717-665-2000
Fax: 717-665-2861

© HARRINGTON HOISTS, INC.
ALL RIGHTS RESERVED

ACC69836-20