



# **WORK-RATED<sup>®</sup>**

## **THE NEW CENTURY SERIES<sup>®</sup>**

### **Wire Rope Electric Hoists**

### **Product Series 32**

### **Parts Manual**

SERIAL NUMBER



This equipment should not be installed, operated or maintained by any person who has not read all the contents of Instruction, Operation, and Maintenance Manual 69833; and Parts Manual 69834. Failure to read and comply with the instructions or any one of the limitations noted in either manual can result in serious bodily injury or death, and/or property damage.

There are no other warranties which extend beyond the description of the Order Acknowledgment and as it may apply to the specifications provided in this publication. THE IMPLIED WARRANTIES OF MERCHANTABILITY AND FITNESS FOR A PARTICULAR PURPOSE ARE EXCLUDED. Acco Material Handling Solutions/Harrington Hoists, Inc., shall in no event be liable for any special, direct, indirect, incidental or consequential damages to anyone beyond the cost of replacement of the goods sold hereby.



# TABLE OF CONTENTS

## NOTICE

Parts Manual 69834 covers parts information in reference to Product Series 32 of the WRIGHT® WORK-RATED® THE NEW CENTURY SERIES® wire rope electric hoist line. This manual includes parts information for a variety of hoist types. Therefore, all parts information may not apply to any one type or size of specific hoist. Disregard those portions of the manual that do not apply. Parts Manual 69834 should be used in conjunction with Manual 69833: Installation, Operation, and Maintenance Manual for WRIGHT® WORK-RATED® Wire Rope Electric Hoists. Refer to Manual 69833 for instructions on installation, operation, inspection, testing, adjusting, and maintaining this equipment; and Parts Manual 69834 for parts information and identification. Use of the term MANUAL refers to both Manual 69833 and Parts Manual 69834.

<u>SUBJECT</u>	<u>PAGE</u>
IMPORTANT INFORMATION AND WARNINGS .....	3
HOIST MOTOR BRAKE ASSEMBLY .....	5
HOIST GEAR HOUSING ASSEMBLY .....	6
HOIST MOTOR - PARALLEL MOUNTED HOIST .....	8
HOIST MOTOR - CROSS MOUNTED HOIST .....	9
SUSPENSION - 2PS REEVING .....	10
SUSPENSION - 2PD REEVING - PARALLEL MOUNTED HOIST .....	11
SUSPENSION - 2PD REEVING - CROSS MOUNTED HOIST .....	12
LOAD BLOCK - 2PS REEVING .....	13
LOAD BLOCK - 2PD REEVING .....	14
GRAVITY LIMIT SWITCH .....	15
GEARED LIMIT SWITCH .....	16
HOIST RECTIFIED D.C. BRAKE CONTROL .....	17
BASIC CONTROL COMPONENTS .....	18
PENDANT CONTROL STATION .....	22
2-WHEEL PLAIN TROLLEY - 4 IN. DIA. WHEEL .....	24
4-WHEEL PLAIN TROLLEY - 4 IN. DIA. WHEEL .....	25
4-WHEEL GEARED TROLLEY - 4 IN. DIA. WHEEL .....	26
4-WHEEL GEARED TROLLEY - DUAL DRIVE - 4 IN. DIA. WHEEL .....	27
4-WHEEL PLAIN TROLLEY - 5 IN. DIA. WHEEL .....	29
4-WHEEL GEARED TROLLEY - 5 IN. DIA. WHEEL .....	30
HAND-GEARED TROLLEY DRIVE .....	31
MOTORIZED TROLLEY DRIVE .....	32
MOTORIZED TROLLEY RIGHT-ANGLE REDUCER .....	33
TROLLEY MOTOR BRAKE ASSEMBLY .....	34
DECK MOUNTED FRAME .....	35
WINCH UNIT FRAME .....	35
TOP-RUNNING TROLLEY .....	36
LOAD BAR ASSEMBLY OR FRAME ASSEMBLY FOR SWIVELING TROLLEYS - PARALLEL MOUNTED HOIST. ....	37
FRAME ASSEMBLY FOR SWIVELING TROLLEYS - CROSS MOUNTED HOIST .....	38
FRAME ASSEMBLY FOR LOUDEN TROLLEYS - CROSS MOUNTED HOIST .....	39
OPTIONAL ELECTRICAL CONTROL ENCLOSURE .....	40

## NOTICE

**TO ORDER PARTS:** Provide part number, part description, quantity required, and Product Number or Serial Number of Hoist.

## IMPORTANT INFORMATION AND WARNINGS

### SAFETY ALERT SYMBOL

The Safety Alert Symbol is used in this manual to indicate hazards and to alert the reader to information that should be known, understood, and followed to avoid DEATH or SERIOUS INJURY.

Read and understand this manual before using the hoist.

Important issues to remember during operation are provided at the hoist control stations, at various locations on the hoist and in the manuals by **DANGER**, **WARNING**, or **CAUTION** instructions or placards, that alert the personnel to potential hazards, proper operation, load limitations, and more.

#### **DANGER**

Indicates an imminently hazardous situation which, if not avoided, will result in death or serious injury.

#### **WARNING**

Indicates a potentially hazardous situation which, if not avoided, could result in death or serious injury.

#### **CAUTION**

Indicates a potentially hazardous situation which, if not avoided, may result in minor or moderate injury. It may also be used to alert against unsafe practices.

### **CAUTION**

These general instructions deal with the normal installation, operation, and maintenance situations encountered with the equipment described herein. The instructions should not be interpreted to anticipate every possible contingency or to anticipate the final system, crane, or configuration that uses this equipment.

This manual includes instructions and parts information for a variety of hoist types; therefore, all instructions and information may not apply to any one type or size of specific hoist. Disregard those portions of the instructions that do not apply.

Record hoist serial number on the front cover of this manual for identification and future reference to avoid referring to the wrong manual for information or instructions on installation, operation, inspection, maintenance, or parts.

Use only Wright® authorized replacement parts in the service and maintenance of this hoist.

### **WARNING**

Equipment described herein is not designed for and should not be used for lifting, supporting, or transporting humans.

Equipment described herein should not be used in conjunction with other equipment unless necessary and/or required safety devices applicable to the system, crane, or application are installed by the system designer, system manufacturer, crane manufacturer, installer, or user.

Modifications to upgrade, rerate, or otherwise alter this equipment shall be authorized only by the original equipment manufacturer or qualified professional engineer.

Equipment described herein may be used in the design and manufacture of cranes or monorails. Additional equipment or devices may be required for the crane or monorail to comply with applicable crane design and safety standards. The crane designer, crane manufacturer, or user is responsible to furnish these additional items for compliance. Refer to ASME B30.17, Safety Standard for Top-Running Single Girder Cranes; ASME B30.2 Safety Standard for Top-Running Double-Girder Cranes; and ASME B30.11 Safety Standard for Underhung Cranes and Monorails. If a below-the-hook lifting device or sling is used with a hoist, refer to ASME B30.9, Safety Standard for Slings, or ASME B30.20, Safety Standard for Below-the-Hook Lifting Devices.

Hoists and cranes, used to handle hot molten material may require additional equipment or devices. Refer to ANSI 2241.2, Safety Requirements for Melting and Pouring of Metals in the Metalcasting Industry.

Electrical equipment described herein is designed and built in compliance with ACCO/Harrington Chain & Lifting Products interpretation of ANSI/NFPA 70, National Electrical Code. The system designer, system manufacturer, crane designer, crane manufacturer, installer, or user is responsible to assure that the installation and associated wiring of these electrical components is in compliance with ANSI/NFPA 70, and all applicable Federal, State, and Local Codes.

Failure to read and comply with any of the limitations noted herein can result in serious bodily injury or death, and/or property damage.

## IMPORTANT INFORMATION AND WARNINGS

---

### DANGER

HAZARDOUS VOLTAGES ARE PRESENT IN THE CONTROL ENCLOSURE, OTHER ELECTRICAL COMPONENTS, AND CONNECTIONS BETWEEN THESE COMPONENTS.

Before performing ANY mechanical or electrical maintenance on the equipment, de-energize (disconnect) the main switch supplying power to the equipment; and lock and tag the main switch in the de-energized position. Refer to ANSI 2244.1, Personnel Protection - Lockout/Tagout of Energy Sources.

Do not operate the equipment without control enclosure cover or covers in place.

Only trained and competent personnel should inspect and repair this equipment.

### NOTICE

It is the responsibility of the owner/user to install, inspect, test, maintain, and operate a hoist in accordance with ASME B30.16, Safety Standard for Overhead Hoists, OSHA Regulations, and ANSI/NFPA 70, National Electrical Code. If the hoist is installed as part of a total lifting system, such as an overhead crane or monorail, it is also the responsibility of the owner/user to comply with the applicable ASME B30 volume that addresses that type of equipment.

It is the responsibility of the owner/user to have all personnel that will install, inspect, test, maintain, and operate a hoist read the contents of this manual and applicable portions of ASME B30.16, Safety Standard for Overhead Hoists, OSHA Regulations, and ANSI/NFPA 70, National Electrical Code. If the hoist is installed as part of a total lifting system, such as an overhead crane, the applicable ASME B30 volume that addresses that type of equipment must also be read by all personnel.

Any ANSI Standards referenced in this manual may be obtained from the American National Standards Institute, 1430 Broadway, New York, New York 10018.

This manual contains information for safe operation of an overhead hoist. Taking precedence over any specific rule, however, is the most important rule of all "**USE COMMON SENSE.**" Operation of an overhead hoist involves more than operating the controls. The operator must consider and anticipate the motions and actions that will occur as a result of operating the controls.

If the hoist owner/user requires additional information, or if any information in the manual is not clear, contact ACCO/Harrington Chain & Lifting Products, or the distributor of the hoist. Do not install, inspect, test, maintain, or operate the hoist unless this information is fully understood.

When contacting ACCO/Harrington Chain & Lifting Products or the distributor of the hoist, always make reference to the serial number of the hoist.

A regular schedule of inspection of the hoist in accordance with the requirements of the ASME B30.16 should be established and records maintained.

### WARNING

Before installing, removing, inspecting, or performing any maintenance on a hoist, the main switch shall be de-energized. Lock and tag the main switch in the de-energized position in accordance with ANSI 2244.1. Follow other maintenance procedures outlined in this manual and applicable ASME B30 volumes.

Additional WARNINGS are listed in various portions of this manual. Personnel shall read and follow these WARNINGS. Failure to read and comply with these WARNINGS as well as other instructions or any limitations noted in this manual and applicable ASME B30 volumes could result in serious bodily injury or death, and/or property damage.

# PARTS LIST - PRODUCT SERIES 32

## HOIST MOTOR BRAKE ASSEMBLY

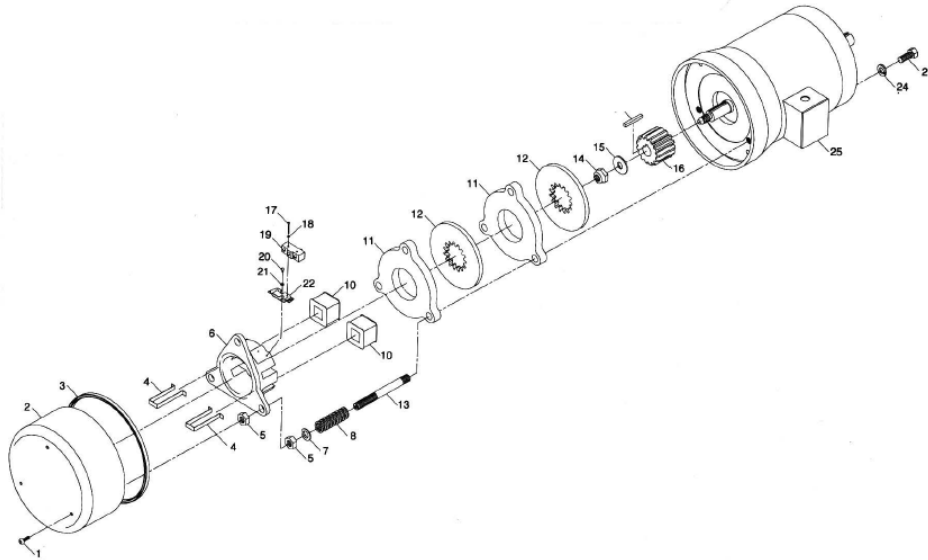

### HOIST MOTOR BRAKE PARTS

ITEM NO.	DESCRIPTION	QTY	18 LB FT TORQUE (a)	33 LB FT TORQUE (a)
			69757-01 (b) (c)	69757-02 (b) (c)
			PART NO.	PART NO.
1	Screw, LOC-WELL (d)	3*	PA7323	PA7323
2	Cover	1	69743	69743
3	Gasket	2.5ft*	PA7110	PA7110
4	Coil Strap	2	51451	51451
5	Nut, Jam	6	24-10	24-10
6	Magnet	1	51445	51445
7	Washer	3	PA2714	PA2714
8	Spring	3	PA7386 (e)	PA6077 (e)
9	Key (g)	1	70879	70879
10	Coil	2	51452	51452
11	Armature Plate	2	51441	51441
12	Lining Disc	2*	51437	51437
13	Stud	3	69755	69755
14	Locknut	1*	PA2434	PA2434
15	Washer	1	15-10-0	15-10-0
16	Hub	1	69754	69754
17	Screw	2	3-06-14	3-06-14
18	Lockwasher	2	19-06	19-06
19	Switch	1	PA6079	PA6079
20	Screw	2	3-08-4	3-08-4
21	Lockwasher	2	19-08C	19-08C
22	Mounting Bracket	1	PA6080	PA6080
23	Bolt	4	(f)	(f)
24	Lockwasher	4	(f)	(f)
25	Motor	1	(f)	(f)

### NOTES:

- (a) On standard single-speed and two-speed hoists, 18 lb. ft. torque brakes are used with 3 HP motors, and 33 lb. ft. torque brakes are used with 5 HP motors.
- (b) Numbers in heading of chart are Hoist Motor Brake Assembly numbers.
- (c) This brake is not used on hoists in Hazardous (Classified) locations as identified by the National Electrical Code.
- (d) Screw with self-locking feature must be utilized. Substitutes are not permissible.
- (e) Springs are color coded. Spring (PA7386) for 18 lb. ft. torque brake is blue color. Spring (PA6077) for 33 lb. ft. torque brake is cadmium color.
- (f) For part numbers, refer to pages 8 and 9.
- (g) Included with hoist motor. Also available individually.

\*Recommended Spare Parts

### HOIST GEAR HOUSING ASSEMBLY

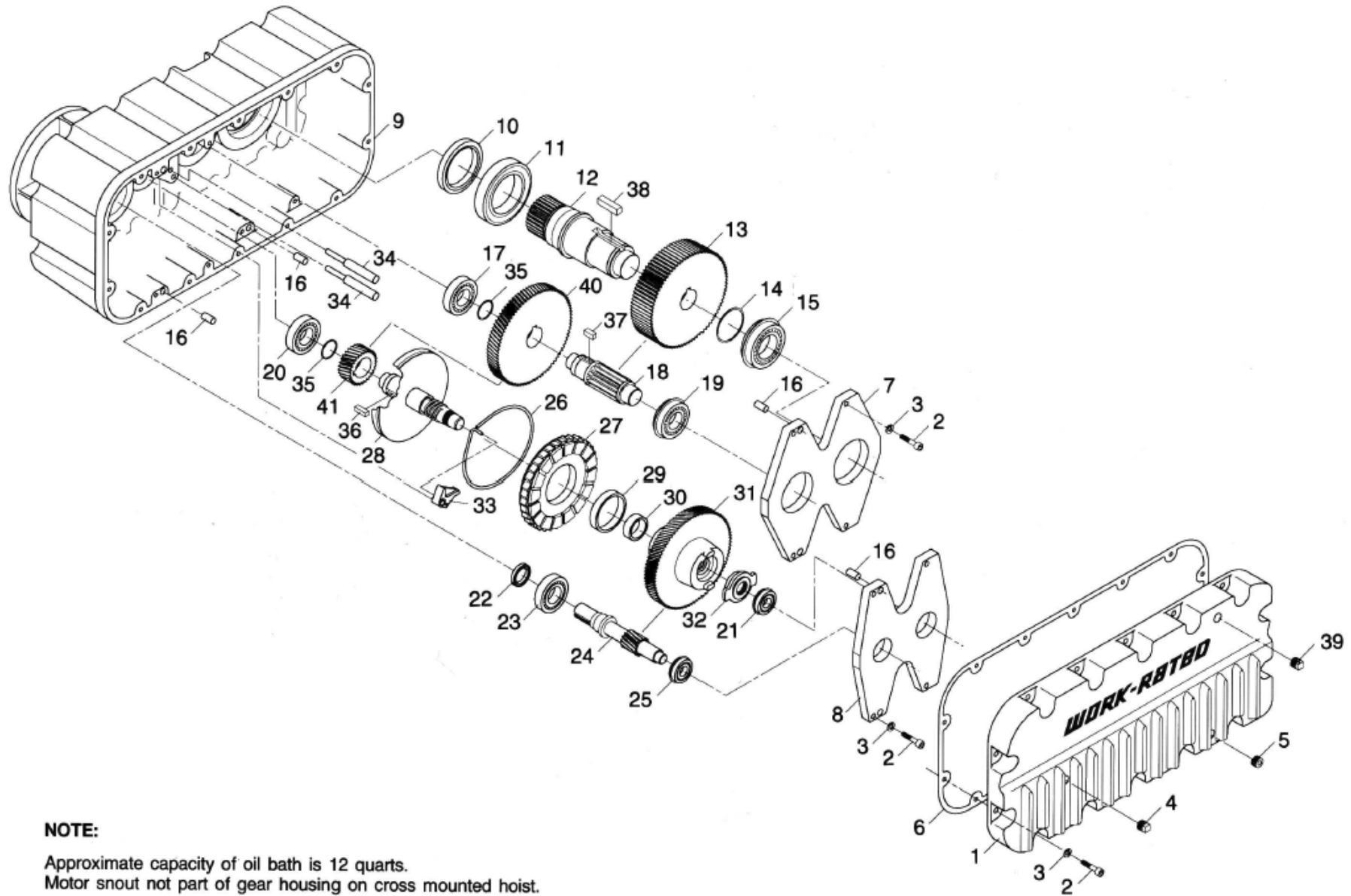

**NOTE:**

Approximate capacity of oil bath is 12 quarts.  
 Motor snout not part of gear housing on cross mounted hoist.

# PARTS LIST - PRODUCT SERIES 32

## HOIST GEAR HOUSING ASSEMBLY

### HOIST GEAR HOUSING PARTS

ITEM NO.	PART NUMBER	DESCRIPTION	QTY/ ASSY
1	69707	Gear Housing Cover	1
2	1-6-20	Bolt, 3/8-16 x 1-1/4	22
3	17-6C	Lock washer, 3/8	22
4	PA7380	Oil Level Plug	1
5	PA798	Pipe Plug	1
6*	69713	Gasket	1
7	69709	Output Spider	1
8	69710	Input Spider	1
9	(a)	Gear Housing	1
10*	PA7390	Oil Seal	1
11	PA7389	Bearing	1
12	69733	Drum Shaft	1
13	69736	Drum Gear	1
14	PA5856	Retaining Pin	1
15	PA5870	Bearing	1
16	PA4846	Dowel Pin	4
17	PA6278	Bearing	1
18	69735	Drum Pinion Shaft	1
19	PA7388	Bearing	1
20	PA6563	Bearing	1
21	PA4847	Bearing	1

ITEM NO.	PART NUMBER	DESCRIPTION	QTY/ ASSY
22*	PA6567	Oil Seal	1
23	PA2389	Bearing	1
24	(b)	Motor Pinion Shaft	1
25	PA7387	Bearing	1
26	55051	Pawl Spring	1
27	54982	Ratchet Unit	1
28	55054	Brake Shaft Unit	1
29	PA6569	Needle Bearing, Outer	1
30	PA6568	Needle Bearing, Inner	1
31	54979	Brake Gear	1
32	54984	Check Sleeve	1
33	40493	Pawl	1
34	69745	Pawl Pin	2
35	PA4053	Retaining Ring	2
36	PA6294	Key	1
37	PA7391	Key	1
38	PA7392	Key	1
39	PA7381	Vent Plug	1
40	(c)	Change Gear	1
41	(c)	Change Pinion	1

\*Recommended Spare Parts

**NOTE:**

- (a) Gear Housing part numbers:  
 Parallel Mounted Hoist-----69712  
 Cross Mounted Hoist-----70777
- (b) Motor Pinion Shaft part numbers:  
 Parallel Mounted Hoist-----69734  
 Cross Mounted Hoist-----70778
- (c) Gearing varies with the speed of the hoist. Three gear sets are available, each identified by Gear Housing Assembly No. 69750 with dash number suffix (-01 thru -03 for parallel mounted hoist and -11 thru -13 for cross mounted hoist). Select proper dash number by counting and comparing number of teeth in gear and pinion.  
 The parts of this assembly which affect the speed of the hoist are Items 40 and 41.

GEAR HOUSING ASSEMBLY		69750-01	69750-02	69750-03	PARALLEL MOUNTED HOIST
		69750-11	69750-12	69750-13	CROSS MOUNTED HOIST
LIFTING SPEED		15 FPM	22 FPM	30 FPM	
ITEM NO.	DESCRIPTION	PART NO.	PART NO.	PART NO.	
40	Gear	69737 (83 teeth)	69738 (76 teeth)	69739 (69 teeth)	
41	Pinion	69742 (29 teeth)	69741 (36 teeth)	69740 (43 teeth)	

# PARTS LIST - PRODUCT SERIES 32

## HOIST MOTOR - PARALLEL MOUNTED HOIST

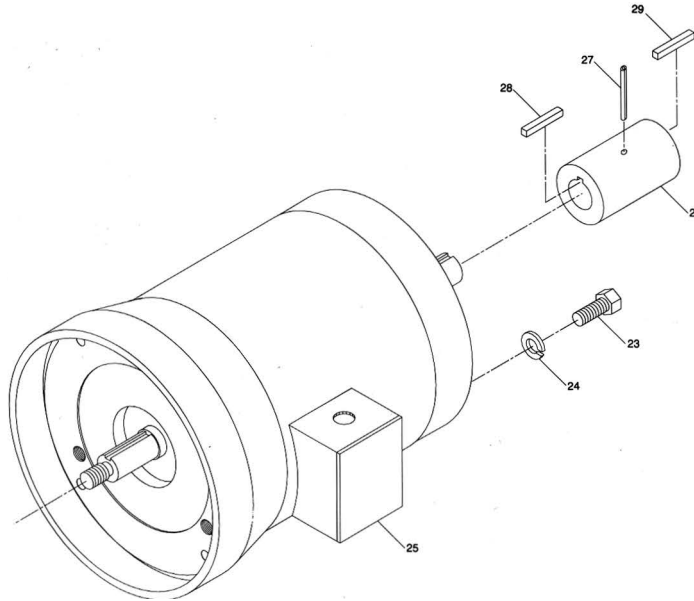

### HOIST MOTOR PARTS

ITEM NO.	PART NO.	DESCRIPTION	QTY.
23	35-8-20C	Bolt, Hex Head	4
24	17-8C	Lockwasher	4
25	(b)	Hoist Motor	1
26	69708	Coupling	1
27	PA5496	Roll Pin	1
28	70879	Key (a)	1
29	71057	Key	1

No Recommended Spare Parts

### NOTES:

(a) Included with hoist motor. Also available individually.

(b) Select standard hoist motor by part number according to motor specifications as follows:

PART NO.	VOLTAGE	HP	RPM	SPEED	FRAME
69777-01	208	3	1800	Single	184TC
69777-02	230/460				
69777-03	575				
69777-04	208	5			
69777-05	230/460				
69777-06	575				
69778-01	208	3/1	1800/600	Two	
69778-02	230				
69778-03	460				
69778-04	575	5 / 1-2/3			
69778-05	208				
69778-06	230				
69778-07	460				
69778-08	575				

For other specified special motors, refer to additional information pages supplied with manual.

# PARTS LIST - PRODUCT SERIES 32

## HOIST MOTOR CROSS MOUNTED HOIST

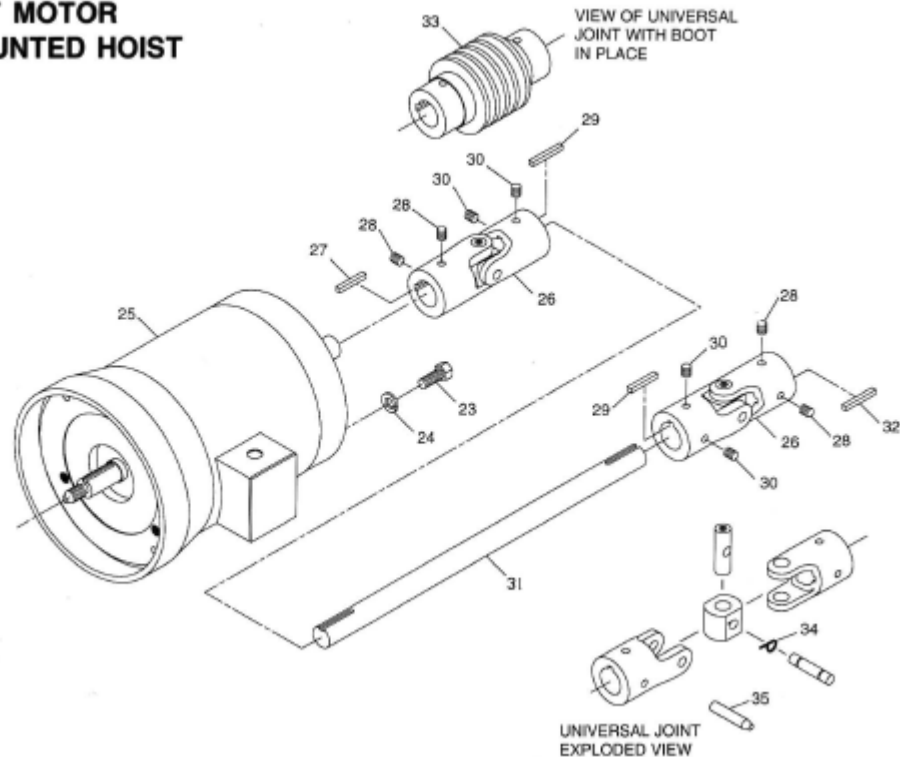

### HOIST MOTOR PARTS

ITEM NO.	PART NO.	DESCRIPTION	QTY.
23	35-8-20C	Bolt, Hex Head	4
24	17-8C	Lockwasher	4
25	(b)	Hoist Motor	1
26	70844	Universal Joint for 20 or 36 ft. lift hoist	2
	70854	Universal Joint for 60 ft. lift hoist	2
27	70879	Key (a)	1
28	12-6-8	Set Screw	4
29	70845	Key for 20 or 36 ft. lift hoist	2
	70846	Key for 60 ft. lift hoist	2
30	12-6-8	Set Screw for 20 or 36 ft. lift hoist	4
	12-7-6	Set Screw for 60 ft. lift hoist	4
31	(c)	Extension Shaft	1
32	70845	Key	1
33	PA7575	Book Kit (d)	2
34*	PA7576	Lock Ring	(e)
35*	70840	Aligning Pin	(f)

\*Recommended Spare Parts

#### NOTES:

- (a) Included with hoist motor. Also available individually.
- (b) Select standard hoist motor by part number according to motor specifications as listed in note b on page 8. For other specified special motors, refer to additional information pages supplied with manual.
- (c) For part number, see Suspension parts list on page 12.
- (d) Kit includes one boot and two ties.
- (e) Included with universal joint. Also available individually. Quantity of one required per joint.
- (f) Not included with hoist. Recommended for re-assembly of universal joint. Used to align parts and spread lock ring.

# PARTS LIST - PRODUCT SERIES 32

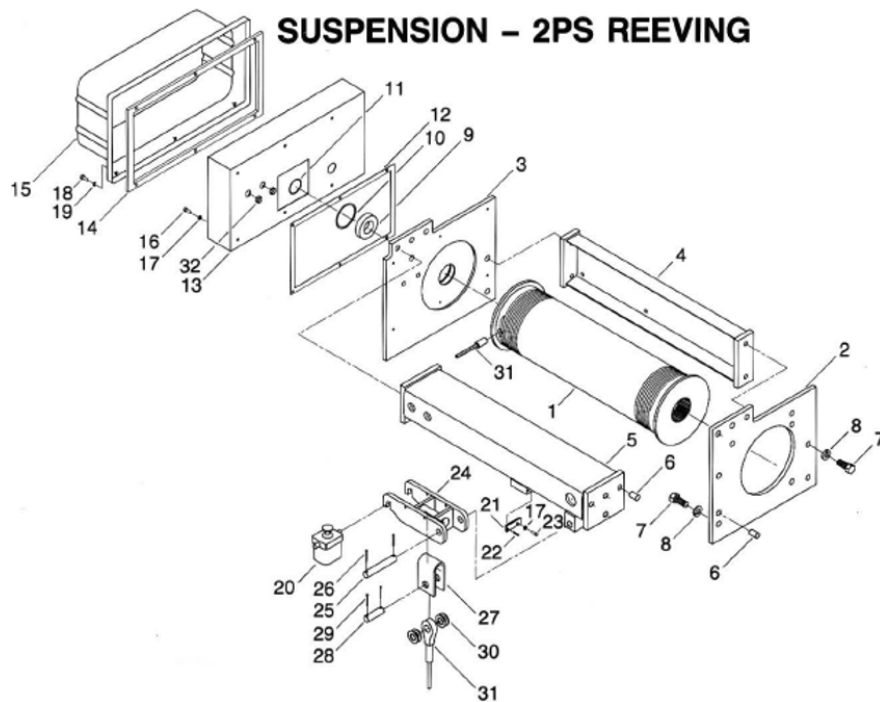

## 2PS SUSPENSION PARTS

ITEM NO.	DESCRIPTION	QTY.	20 FT. LIFT PART NO.	25 FT. LIFT PART NO.	36 FT. LIFT PART NO.	54 FT. LIFT PART NO.	65 FT. LIFT PART NO.	86 FT. LIFT PART NO.
1	Drum Single Grooving	1	69725-01	69725-02	69725-03	69725-04	69725-05	69725-06
2	End Plate Gear End	1	69720	69720	69720	69720	69720	69720
3	End Plate Control End	1	69721	69721	69721	69721	69721	69721
4	Side Frame	1	69842-01	69842-02	69842-03	69842-04	69842-05	69842-06
5	Frame Unit	1	69719-01	69719-02	69719-03	69719-04	69719-05	69719-06
6	Dowel Pin	6	PA7394	PA7394	PA7394	PA7394	PA7394	PA7394
7	Hex Head Bolt	12	35-10-20C	35-10-20C	35-10-20C	35-10-20C	35-10-20C	35-10-20C
8	Lockwasher	12	17-10C	17-10C	17-10C	17-10C	17-10C	17-10C
9	Bearing	1	PA7393	PA7393	PA7393	PA7393	PA7393	PA7393
10	Retaining Ring	1	PA6940	PA6940	PA6940	PA6940	PA6940	PA6940
11	Retaining Ring	1	PA6813	PA6813	PA6813	PA6813	PA6813	PA6813
12	Gasket	1	69774	69774	69774	69774	69774	69774
13	Enclosure	1	69773	69773	69773	69773	69773	69773
14	Gasket	1	58531	58531	58531	58531	58531	58531
15	Cover	1	52823	52823	52823	52823	52823	52823
16	Hex Head Bolt	6	35-4-6C	35-4-6C	35-4-6C	35-4-6C	35-4-6C	35-4-6C
17	Lockwasher	7	17-4C	17-4C	17-4C	17-4C	17-4C	17-4C
18	Captive Screw	6	58597	58597	58597	58597	58597	58597
19	Retaining Ring	6	PA6634	PA6634	PA6634	PA6634	PA6634	PA6634
20	Overload Cut-off 1 Ton	1	39168-04	39168-04	39168-04	39168-04	39168-04	39168-04
20	Overload Cut-off - 2 & 3 Ton	1	39169-04	39169-04	39169-04	39169-04	39169-04	39169-04
21	Keeper Plate	1	53219	53219	53219	53219	53219	53219
22	Roll Pin	1	PA4607	PA4607	PA4607	PA4607	PA4607	PA4607
23	Hex Head Bolt	1	35-4-8C	35-4-8C	35-4-8C	35-4-8C	35-4-8C	35-4-8C
24	Rope End Mounting Unit	1	69753	69753	69753	69753	69753	69753
25	Pin	1	69717	69717	69717	69717	69717	69717
26	Cotter Pin	2	PA1364	PA1364	PA1364	PA1364	PA1364	PA1364
27	Rope Hanger	1	69730	69730	69730	69730	69730	69730
28	Pin	1	69797	69797	69797	69797	69797	69797
29	Cotter Pin	2	PA1409	PA1409	PA1409	PA1409	PA1409	PA1409
30	Washer	4	15-12-1C	15-12-1C	15-12-1C	15-12-1C	15-12-1C	15-12-1C
31	Wire Rope Assembly (a)	1*	69727-01	69727-02	69727-03	69727-04	69727-05	69727-06
32	Grommet	2	PA7409	PA7409	PA7409	PA7409	PA7409	PA7409

\*Recommended Spare Parts

**NOTE:** (a) Part numbers shown for Item 31, Wire Rope Assembly, are for standard hoists using 3/8 dia. 6x37 XIP wire rope. For special hoists using other size or type wire rope, refer to the wire rope part number listed in additional pages included with this manual; or contact Acco/Harrington Chain & Lifting Products or the distributor of the hoist.

# PARTS LIST - PRODUCT SERIES 32

## SUSPENSION – 2PD REEVING PARALLEL MOUNTED HOIST

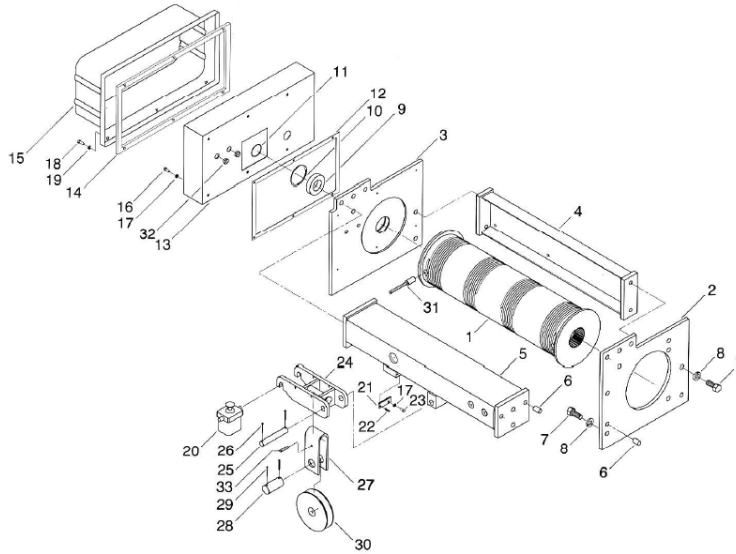

### 2PD SUSPENSION PARTS

ITEM NO.	DESCRIPTION	QTY.	20 FT. LIFT PART NO.	26 FT. LIFT PART NO.	36 FT. LIFT PART NO.	60 FT. LIFT PART NO.	85 FT. LIFT PART NO.
1	Drum, Double Grooving	1	69726-04	69726-05	69726-06	69726-07	69726-08
2	End Plate Gear End	1	69720	69720	69720	69720	69720
3	End Plate Control End	1	69721	69721	69721	69721	69721
4	Side Frame	1	69842-04	69842-05	69842-06	69842-07	69842-08
5	Frame Unit (c)	1	69718-04	69718-05	69718-06	69744-07	69744-08 (b)
6	Dowel Pin	6	PA7394	PA7394	PA7394	PA7394	PA7394
7	Hex Head Bolt	12	35-10-20C	35-10-20C	35-10-20C	35-10-20C	35-10-20C
8	Lockwasher	12	17-10C	17-10C	17-10C	17-10C	17-10C
9	Bearing	1	PA7393	PA7393	PA7393	PA7393	PA7393
10	Retaining Ring	1	PA6940	PA6940	PA6940	PA6940	PA6940
11	Retaining Ring	1	PA6813	PA6813	PA6813	PA6813	PA6813
12	Gasket	1	69774	69774	69774	69774	69774
13	Enclosure	1	69773	69773	69773	69773	69773
14	Gasket	1	58531	58531	58531	58531	58531
15	Cover	1	52823	52823	52823	52823	52823
16	Hex Head Bolt	6	35-4-6C	35-4-6C	35-4-6C	35-4-6C	35-4-6C
17	Lockwasher	7	17-4C	17-4C	17-4C	17-4C	17-4C
18	Captive Screw	6	58597	58597	58597	58597	58597
19	Retaining Ring	6	PA6634	PA6634	PA6634	PA6634	PA6634
20	Overload Cut-off 2 & 3 Ton	1	39169-04	39169-04	39169-04	39169-04	39169-04
20	Overload Cut-off - 5 Ton	1	39170-04	39170-04	39170-04	39170-04	39170-04
21	Keeper Plate	1	53219	53219	53219	53219	53219
22	Roll Pin	1	PA4607	PA4607	PA4607	PA4607	PA4607
23	Hex Head Bolt	1	35-4-8C	35-4-8C	35-4-8C	35-4-8C	35-4-8C
24	Sheave Mounting Unit	1	69753	69753	69753	69753	69753
25	Pin	1	69717	69717	69717	69717	69717
26	Cotter Pin	2	PA1364	PA1364	PA1364	PA1364	PA1364
27	Sheave Hanger	1	69731	69731	69731	69731	69731
28	Pin	1	69747	69747	69747	69747	69747
29	Cotter Pin	2	PA1771	PA1771	PA1771	PA1771	PA1771
30	Polyamide Equalizing Sheave	1	69746	69746	69746	69746	69746
30	Steel Equalizing Sheave	1	69775	69775	69775	69775	69775
31	Wire Rope Assembly (a)	1*	69728-04	69728-05	69728-06	69728-07	69728-08
32	Grommet	2	PA7409	PA7409	PA7409	PA7409	PA7409
33	Pin	1	PA5342	PA5342	PA5342	PA5342	PA5342

\*Recommended Spare Parts

**NOTE:** (a) Part numbers shown for Item 31, Wire Rope Assembly, are for standard hoists using 3/8 dia. 6x37 XIP wire rope. For special hoists using other size or type wire rope, refer to the wire rope part number listed in additional pages included with this manual; or contact Acco/Harrington Chain & Lifting Products or the distributor of the hoist.

(b) For deck-mounted, use Part No. 70130.

(c) Use of Swivel Trolleys requires different Frame Unit. See page 37.

# PARTS LIST - PRODUCT SERIES 32

## SUSPENSION – 2PD REEVING CROSS MOUNTED HOIST

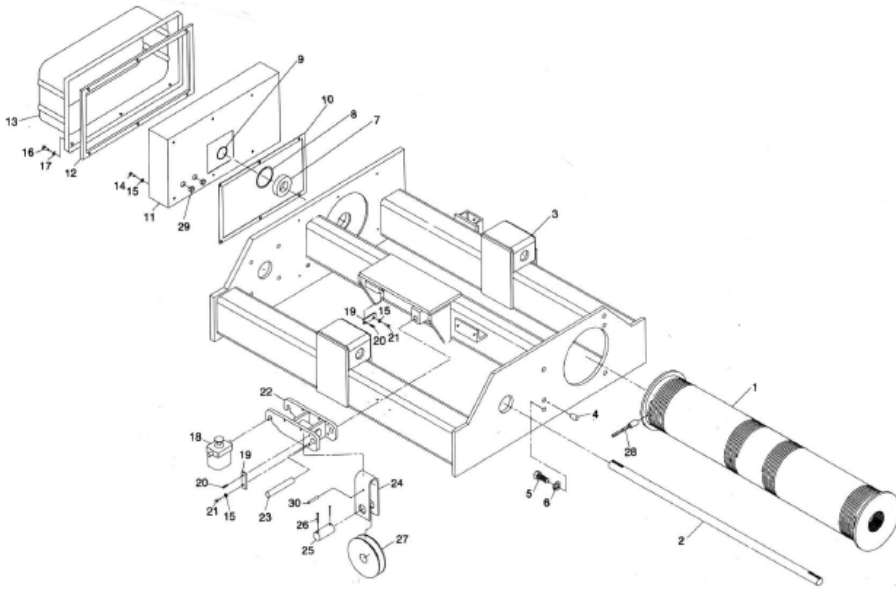

### 2PD SUSPENSION PARTS

ITEM NO.	DESCRIPTION	QTY.	20 FT. LIFT PART NO.	36 FT. LIFT PART NO.	60 FT. LIFT PART NO.
1	Drum Double Grooving	1	69726-04	69726-06	69726-07
2	Extension Shaft	1	70785-04	70785-06	70799-07
3	Frame Unit (b)	1	70784-04	70784-06	70784-07
4	Dowel Pin	2	PA7394	PA7394	PA7394
5	Hex Head Bolt	4	35-10-20C	35-10-20C	35-10-20C
6	Lockwasher	4	17-10C	17-10C	17-10C
7	Bearing	1	PA7393	PA7393	PA7393
8	Retaining Ring	1	PA6940	PA6940	PA6940
9	Retaining Ring	1	PA6813	PA6813	PA6813
10	Gasket	1	69774	69774	69774
11	Enclosure	1	69773	69773	69773
12	Gasket	1	58531	58531	58531
13	Cover	1	52823	52823	52823
14	Hex Head Bolt	6	35-4-6C	35-4-6C	35-4-6C
15	Lockwasher	8	17-4C	17-4C	17-4C
16	Captive Screw	6	58597	58597	58597
17	Retaining Ring	6	PA6634	PA6634	PA6634
18	Overload Cut-off 2 & 3 Ton	1	39169-04	39169-04	39169-04
18	Overload Cut-off 5 Ton	1	39170-04	39170-04	39170-04
19	Keeper Plate	2	53219	53219	53219
20	Roll Pin	2	PA4607	PA4607	PA4607
21	Hex Head Bolt	2	35-4-8C	35-4-8C	35-4-8C
22	Sheave Mounting Unit	1	69753	69753	69753
23	Pin	1	70839	70839	70839
24	Sheave Hanger	1	69731	69731	69731
25	Pin	1	69747	69747	69747
26	Cotter Pin	2	PA1771	PA1771	PA1771
27	Polyamide Equalizing Sheave	1	69746	69746	69746
27	Steel Equalizing Sheave	1	69775	69775	69775
28	Wire Rope Assembly (a)	1*	69728-04	69728-06	69728-07
29	Grommet	2	PA7409	PA7409	PA7409
30	Pin	1	PA5342	PA5342	PA5342

\*Recommended Spare Parts

**NOTE:** (a) Part numbers shown for Item 28, Wire Rope Assembly, are for standard hoists using 3/8 dia. 6x37 XIP wire rope. For special hoists using other size or type wire rope, refer to the wire rope part number listed in additional pages included with this manual; or contact Acco/Harrington Chain & Lifting Products or the distributor of the hoist.

(b) Use of Swivel Trolleys requires different Frame Unit. See page 38.

# PARTS LIST – PRODUCT SERIES 32

## LOAD BLOCK - 2PS REEVING 3/8" ROPE DIAMETER

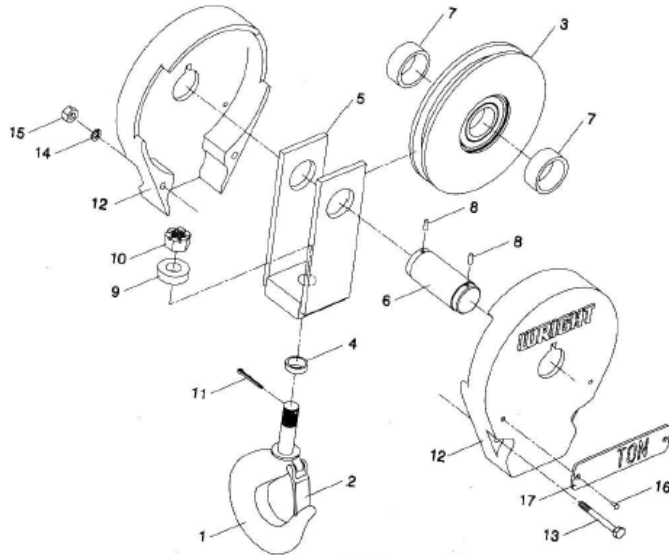

- Load Block Assembly 69550-01 - Steel Spring Latch Type Hook, Polyamide Sheave
- Load Block Assembly 69550-02 - Bullard Swivel Latch Type Hook, Polyamide Sheave
- Load Block Assembly 69550-03 - Bronze Spring Latch Type Hook, Polyamide Sheave
- Load Block Assembly 69550-04 - Steel Spring Latch Type Hook, Steel Sheave
- Load Block Assembly 69550-05 - Bullard Swivel Latch Type Hook, Steel Sheave
- Load Block Assembly 69550-06 - Bronze Spring Latch Type Hook, Steel Sheave

### LOAD BLOCK PARTS

ITEM NO.	DESCRIPTION	QTY	STEEL SPRING LATCH TYPE HOOK	BULLARD SWIVEL LATCH TYPE HOOK	BRONZE SPRING LATCH TYPE HOOK
1	Hook without hole in tip	1	69324	69326	69548
1	Hook with hole in tip	1	70891	N/A	70899
2	Latch for hook without hole in tip	1	PA3825	N/A	PA5325
2	Latch for hook with hole in tip	1	PA7581	N/A	PA7582
3	Polyamide Sheave with Bearing	1	69561	69561	69561
3	Steel Sheave with Bearing	1	69562	69562	69562
4	Spacer	0	N/A	N/A	N/A
5	Frame	1	69549	69549	69549
6	Axle	1	69560	69560	69560
7	Spacer	2	69563	69563	69563
8	Roll Pin	2	PA4607	PA4607	PA4607
9	Thrust Bearing	1	PA1367	PA1367	PA1367
10	Slotted Hex Nut	1	26-14C	26-14C	26-14C
11	Cotter Pin	1	PA3808	PA3808	PA3808
12	Cover	2	55229	55229	55229
13	Hex Head Bolt	2	35-5-48	35-5-48	35-5-48
14	Lockwasher	2	17-5C	17-5C	17-5C
15	Hex Nut	2	22-5C	22-5C	22-5C
16	Drive Screw	4	PA893	PA893	PA893
17	Capacity Plate	2	(b)	(b)	(b)

No Recommended Spare Parts

### NOTES:

- (a) Current style Spring Latch Hooks are being phased out by Acco/Harrington's supplier. The new style Spring Latch Hooks have a hole in the tip of the hook. This hole allows the addition of a cotter pin to prevent the latch from opening. Cotter pin is not supplied by Acco/Harrington. New style hooks are interchangeable with old style hooks, but new style hooks have a thicker cross section. Latches are not interchangeable between the two style hooks. As soon as stock of current style hook is depleted, current style hook will no longer be available. Latches for current style hooks will continue to be available. When ordering, identify whether or not hook has a hole in the tip and select part numbers accordingly from the above chart.
- (b) Capacity Plate part numbers:
  - 1 Ton - 69683-010      1 tonne - 69683-1010
  - 2 Ton - 69683-020      2 tonne - 69683-1020
  - 3 Ton - 69683-030      3 tonne - 69683-1030

# PARTS LIST – PRODUCT SERIES 32

## LOAD BLOCK - 2PD REEVING 3/8" ROPE DIAMETER

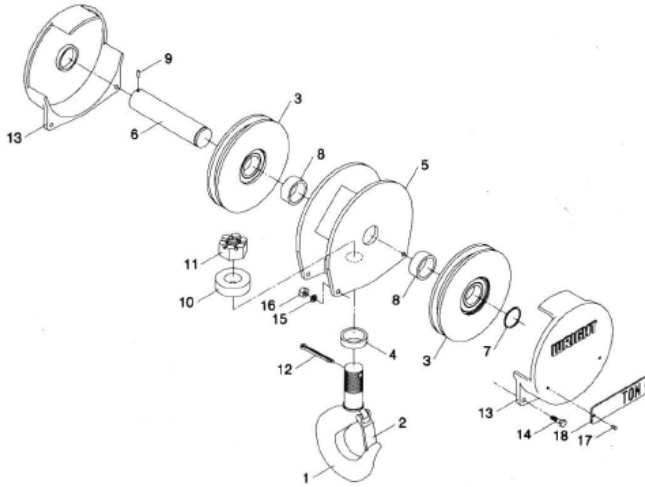

- Load Block Assembly 69554-01 - Steel Spring Latch Type Hook, Polyamide Sheave
- Load Block Assembly 69554-02 - Bullard Swivel Latch Type Hook, Polyamide Sheave
- Load Block Assembly 69554-03 - Bronze Spring Latch Type Hook, Polyamide Sheave
- Load Block Assembly 69554-04 - Steel Spring Latch Type Hook, Steel Sheave
- Load Block Assembly 69554-05 - Bullard Swivel Latch Type Hook, Steel Sheave
- Load Block Assembly 69554-06 - Bronze Spring Latch Type Hook, Steel Sheave

### LOAD BLOCK PARTS

ITEM NO.	DESCRIPTION	QTY	STEEL SPRING LATCH TYPE HOOK	BULLARD SWIVEL LATCH TYPE HOOK	BRONZE SPRING LATCH TYPE HOOK
1	Hook without hole in tip	1	41732 (a)	41794	42643 (a)
1	Hook with hole in tip	1	70892 (a)	N/A	70900 (a)
2	Latch for hook without hole in tip	1	PA5325 (a)	N/A	PA5327 (a)
2	Latch for hook with hole in tip	1	PA7582 (a)	N/A	PA7583 (a)
3	Polyamide Sheave with Bearing	2	69561	69561	69561
3	Steel Sheave with Bearing	2	69562	69562	69562
4	Spacer	1	N/A	41797	N/A
5	Frame	1	69586	69586	69586
6	Axle	1	69587	69587	69587
7	Retaining Ring	1	PA7349	PA7349	PA7349
8	Spacer	2	69563	69563	69563
9	Roll Pin	1	PA4607	PA4607	PA4607
10	Thrust Bearing	1	PA1082	PA1082	PA1082
11	Slotted Hex Nut	1	26-20	26-20	26-20
12	Cotter Pin	1	PA1771	PA1771	PA1771
13	Cover	2	69589	69589	69589
14	Hex Head Bolt	4	35-5-20	35-5-20	35-5-20
15	Lockwasher	4	17-5C	17-5C	17-5C
16	Hex Nut	4	22-5C	22-5C	22-5C
17	Drive Screw	4	PA893	PA893	PA893
18	Capacity Plate	2	(b)	(b)	(b)

No Recommended Spare Parts

### NOTES:

(a) Current style Spring Latch Hooks are being phased out by Acco/Harrington's supplier. The new style Spring Latch Hooks have a hole in the tip of the hook. This hole allows the addition of a cotter pin to prevent the latch from opening. Cotter pin is not supplied by Acco/Harrington. New style hooks are interchangeable with old style hooks, but new style hooks have a thicker cross section. Latches are not interchangeable between the two style hooks. As soon as stock of current style hook is depleted, current style hook will no longer be available. Latches for current style hooks will continue to be available. When ordering, identify whether or not hook has a hole in the tip and select part numbers accordingly from the above chart.

(b) Capacity Plate part numbers:

- 1 Ton - 69683-010      1 tonne - 69683-1010
- 2 Ton - 69683-020      2 tonne - 69683-1020
- 3 Ton - 69683-030      3 tonne - 69683-1030
- 5 Ton - 69683-050      5 tonne - 69683-1050

# PARTS LIST - PRODUCT SERIES 32

## GRAVITY LIMIT SWITCH

Gravity Limit Switch Assembly 70265-01 – Used on Series 32 and Series 33, 2PS, 2PD, and 4 PD hoists.

Gravity Limit Switch Assembly 70265-02 – Used on Series 33 4PS, Series 34, and Series 35 hoists.

### GRAVITY LIMIT SWITCH PARTS

ITEM NO.	PART NO.	DESCRIPTION	QTY. 70265-01	QTY. 70265-02
1	70262	Enclosure	1	1
2	PA3598	Bushing	(a)	(a)
3	69793	Arm	1	1
4	3-08-8C	Screw	1	1
5	70264	Cam	1	1
6	3-05-14C	Screw	2	2
7	PA7400	Spring	1	1
8	3-05-2C	Screw	3	3
9	3-010-6C	Screw	1	1
10	61717	Switch Unit	1	1
11	70263	Shaft	1	1
12	64104	Insulator	1	1
13	PA3810	Spring Pin	1	1
14	PA5155	Self-tapping Screw	2	2
15	69804	Cover	1	1
16	69805	Gasket	1	1
17	PA2242	Oval Cable Sleeve	2	2
18	PA3113	Wire Rope	A.R.	A.R.
19	69827	Weight Half	2	0
20	35-4-16C	Bolt	2	0
21	22-4C	Hex Nut	2	2
22	17-4C	Lockwasher	2	2
23	19-08C	Lockwasher, Int. Tooth	1	1
24	3-010-6C	Screw	0	1
25	30-01C	Hex Nut	0	1
26	35-4-24C	Bolt	0	2
27	A2007L1	Weight Half, Left	0	1
28	A2007R1	Weight Half, Right	0	1

No Recommended Spare Parts

### NOTES:

- (a) Included with Item 1.
- (b) Gravity limit switch attached to hoist frame with two (2) Round Head Screws, Part No. 3-010-16C, and two (2) Locknuts, Part No. PA2423.

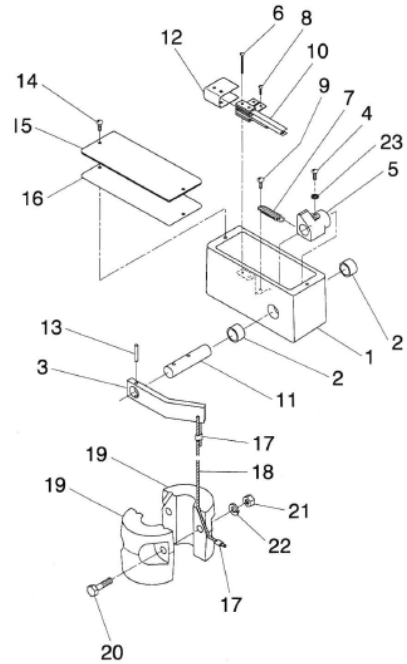

ASSEMBLY-01

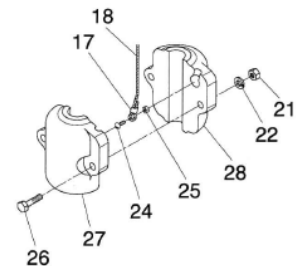

ASSEMBLY-02

**GEARED LIMIT SWITCH**

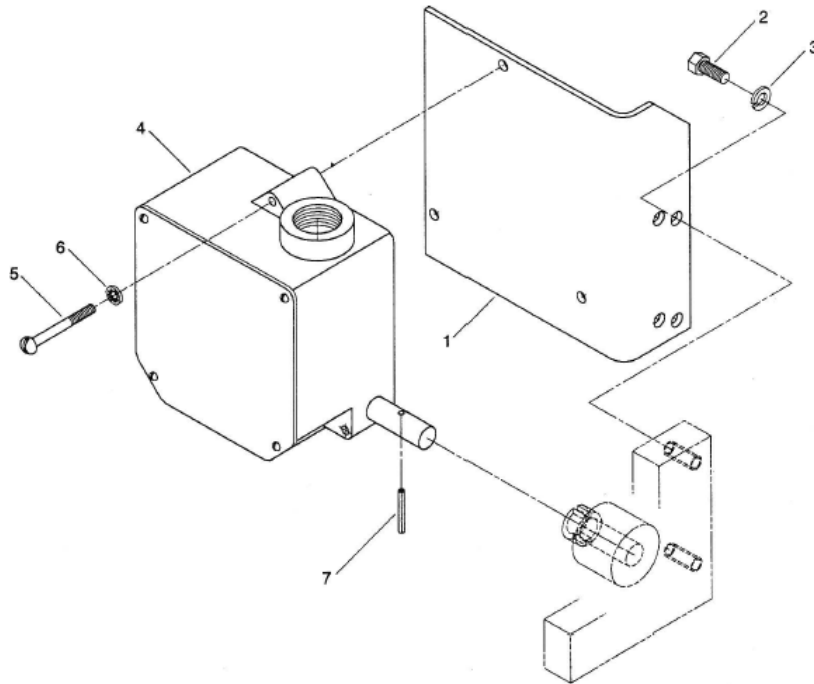

**GEARED LIMIT SWITCH PARTS**

ITEM NO.	PART NO.	DESCRIPTION	QTY.
1	69965	Mounting Plate	1
2	35-4-8C	Hex Head Bolt	2
3	17-4C	Lockwasher	2
4 (a)	61649-07	Geared Limit Switch 2 Circuit - 40:1 Ratio - 38 Max. Turns	1
	61649-05	Geared Limit Switch 4 Circuit - 40:1 Ratio - 38 Max. Turns	1
	61649-08	Geared Limit Switch 2 Circuit - 80:1 Ratio - 75 Max. Turns	1
	61649-06	Geared Limit Switch 4 Circuit - 80:1 Ratio - 75 Max. Turns	1
	61649-01	Geared Limit Switch 2 Circuit - 111:1 Ratio - 104 Max. Turns	1
	61649-03	Geared Limit Switch 4 Circuit - 111:1 Ratio - 104 Max. Turns	1
5	3-010-24C	Round Head Screw	3
6	19-010C	Lockwasher	3
7	PA3810	Drive Pin	1

No Recommended Spare Parts

**NOTE:**

(a) For Geared Limit Switch selection, the maximum possible number of input shaft turns must be greater than the total number of grooves on a single reeved drum or the total number of grooves per side on a double reeved drum. With standard grooving, the following drum numbers are the maximum length drums on which the indicated switch ratios can be used.

40:1 Ratio can be used up to 2PS Drum Number 2 or 2PD Drum Number 5.

80:1 Ratio can be used up to 2PS Drum Number 4 or 2PD Drum Number 7.

111:1 Ratio can be used up to 2PS Drum Number 6 or 2PD Drum Number 8.

# PARTS LIST - PRODUCT SERIES 32

## HOIST RECTIFIED D.C. BRAKE CONTROL

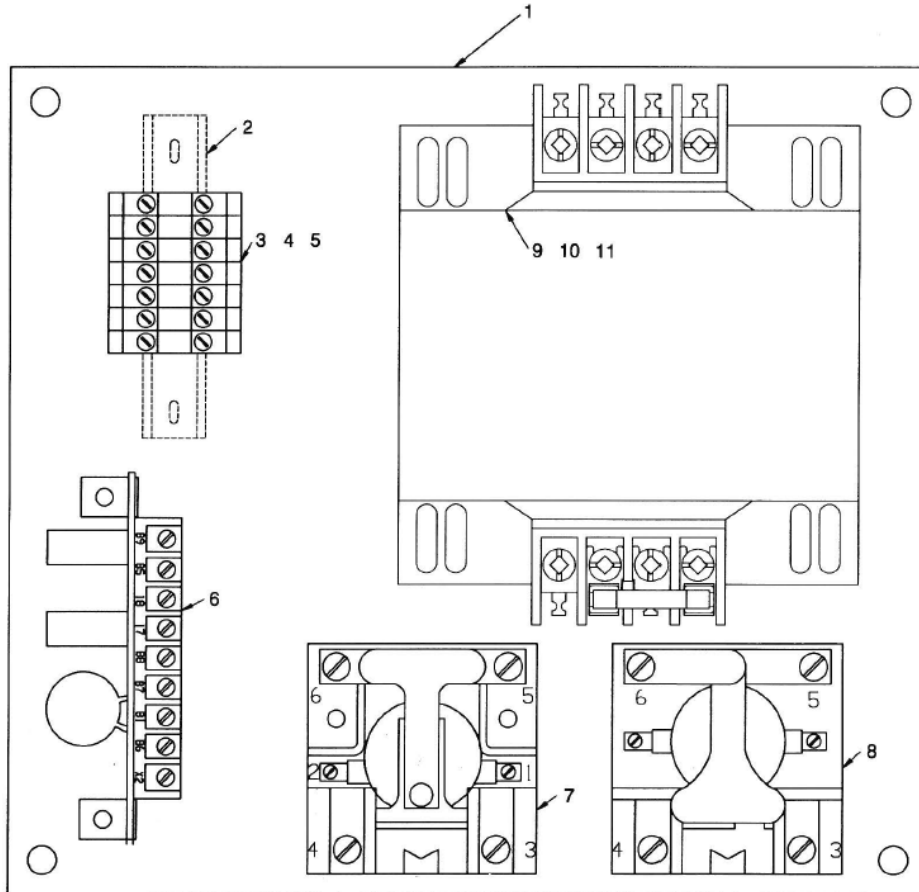

### REPLACEMENT PARTS

ITEM NO.	PART NUMBER	DESCRIPTION
1	86821	Panel, Drilled
2	86714-12	Din Rail, Pre-cut, 3-1/2" L.
3	86710-05	Terminal, End Anchor
4	86710-07	Terminal, End Barrier
5	86710-01	Terminal, Control
6*	86712	Brake Circuit Control Board
7*	PA6496	Relay, Brake Ctrl. (BC) for 115V. Control
	PA6373	Relay, Brake Ctrl. (BC) for 24V. Control
8*	PA6254	Relay, Brake (BR) for 115V. Control
	PA6255	Relay, Brake (BR) for 24V. Control
9	52429-80	Transformer Fuse Holder

ITEM NO.	PART NUMBER	DESCRIPTION
10*	PA7330	Transformer Fuse (250VA)
	PA6334	Transformer Fuse (350VA)
	PA6335	Transformer Fuse (500VA)
11	52429-07	Transformer, 250VA 200-115
	52429-19	Transformer, 250VA 230/460-115
	52429-42	Transformer, 250VA 575-115
	52429-09	Transformer, 350VA 200-115
	52429-21	Transformer, 350VA 230/460-115
	52429-44	Transformer, 250VA 575-115
	52429-10	Transformer, 500VA 200-115
	52429-22	Transformer, 500VA 230/460-115
	52429-45	Transformer 500VA 575-115

\*Recommended Spare Parts

# PARTS LIST - PRODUCT SERIES 32

## BASIC CONTROL COMPONENTS

SINGLE OR TWO SPEED HOIST, LUG MTD., PLAIN OR GEARED TROLLEY OR SINGLE SPEED HOIST SINGLE SPEED TROLLEY COMBINATION

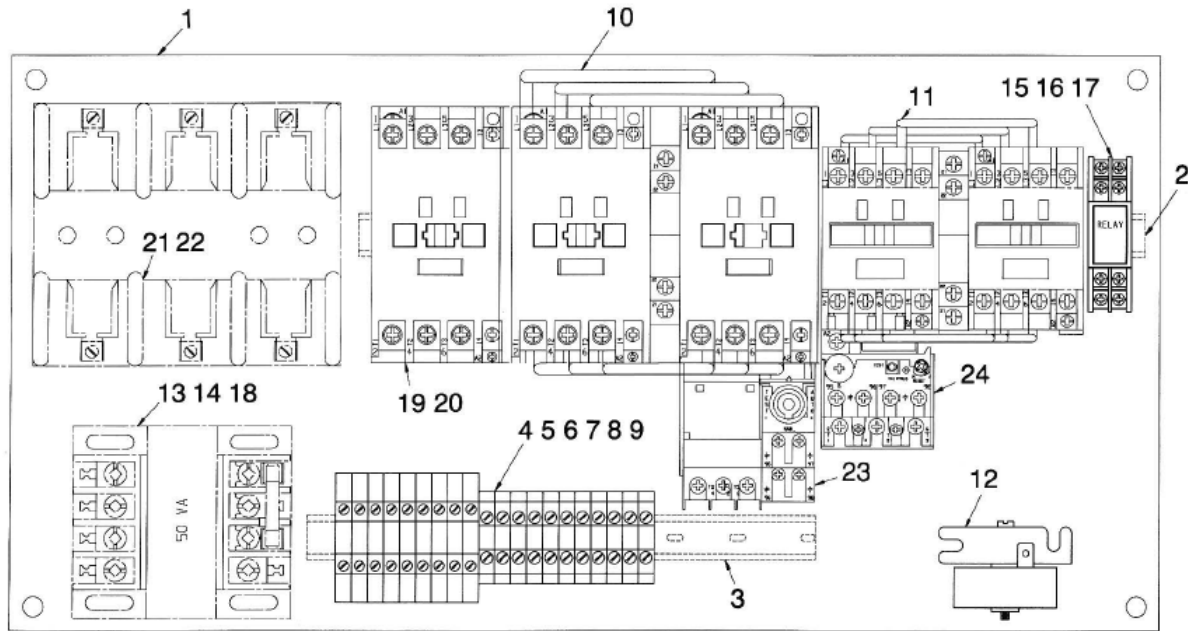

### REPLACEMENT PARTS

ITEM NO.	PART NUMBER	DESCRIPTION
1	86822	Panel, Drilled
2	86714-06	DIN Rail, Pre-cut, 12"
3	86714-02	DIN Rail, Pre-cut, 8"
4	86710-04	Terminal, Grounding
5	86710-05	Terminal, End Anchor
6	86710-06	Terminal, End Barrier, Power
7	86710-07	Terminal, End Barrier, Control
8	86710-01	Terminal, Control
9	86710-02	Terminal, Power
10*	86729-01	Contact, Reversing, (or Two Speed) 115 V (Hoist)
	86729-02	Contact, Reversing, (or Two Speed) 24 V (Hoist)
11*	86727-01	Contact, Reversing, 115 V (Trolley)
	86727-02	Contact, Reversing, 24 V (Trolley)
12	PA7103	Time Capsule, 115 V (Two Speed Only)
	PA7104	Time Capsule, 24 V (Two Speed Only)
13	52429-80	Transformer Fuse Clip (24 V controls only)
14	PA7330	Transformer Fuse (24 V controls only)

\*Recommended Spare Parts

ITEM NO.	PART NUMBER	DESCRIPTION
15*	PA7382	Relay, Control, 115 V (Two Speed Only)
	PA7383	Relay, Control, 24 V (Two Speed Only)
16	PA7384	Relay, Socket
17	PA7385	Relay, Retainer Clip
18	52429-XX	Transformer (24 V controls only) -52 for 200 V; -26 for 230/460 V; -64 for 575 V Supply
	86733-01	Mainline Contactor, 115 V (Optional)
19	86733-02	Mainline Contactor, 24 V (Optional)
	86737-10	Contact Block, Aux. (used with Mainline Contactor)
21	PA7341	Fuse Block, Mtr. Ckt. 30A. (Optional)
	PA7342	Fuse Block, Mtr. Ckt. 60A. (Optional)
22*	86709-XX	Fuse, Mtr. Ckt. (Optional) see note below
23	86736-XX	Overload Relay, Hoist (Optional) see note below
24	86736-XX	Overload Relay, Trolley (Optional) see note below
Not Shown	69505-02	Danger Label, Electrical

### NOTE:

When ordering Motor Circuit Fuses or Overload Relays, provide as much information about the hoist as possible. Hoist serial number, motor H.P's., full load currents, supply voltage, etc.

# PARTS LIST - PRODUCT SERIES 32

## BASIC CONTROL COMPONENTS

SINGLE SPEED HOIST, SINGLE SPEED HOIST & SINGLE SPEED TROLLEY, SINGLE SPEED HOIST AND TWO SPEED TROLLEY OR TWO SPEED HOIST WITH PLAIN OR HAND GEARED TROLLEY COMBINATION WHEN GEARED LIMIT SWITCH IS NOT SPECIFIED

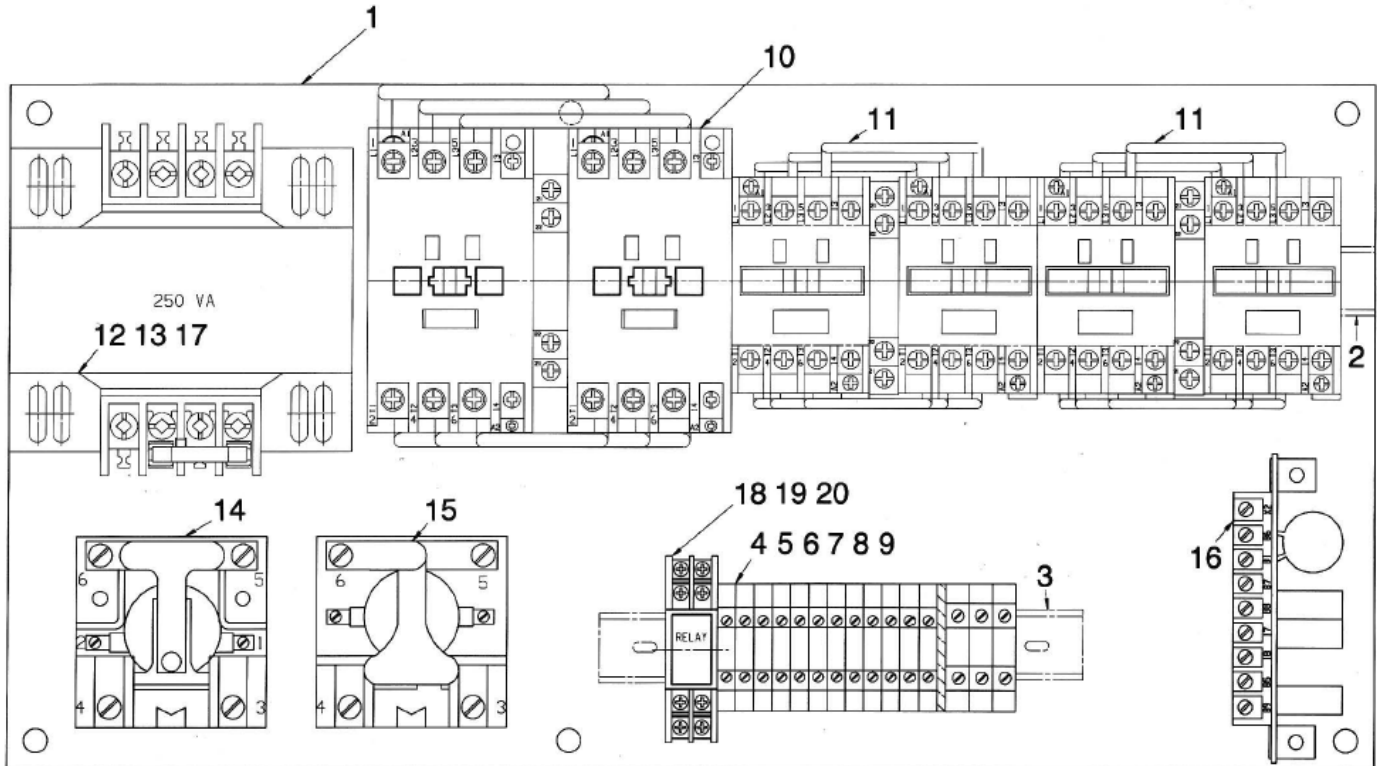

### REPLACEMENT PARTS

ITEM NO.	PART NUMBER	DESCRIPTION
1	86822	Panel, Drilled
2	86714-11	Din Rail, Pre-cut, 11" L.
3	86714-01	Din Rail, Pre-cut, 6-1/2" L.
4	86710-04	Terminal, Grounding
5	86710-05	Terminal, End Anchor
6	86710-06	Terminal, End Barrier, Power
7	86710-07	Terminal, End Barrier, Control
8	86710-01	Terminal, Control
9	86710-02	Terminal, Power
10*	86729-01	Contactors, Rev. 115 V. (Hoist) (For two speed contactor use 86729-01 and remove load side power jumpers [black wires])
11*	86727-01	Contactors, Rev. 115 V. (Trolley) (For two speed contactor use 86727-01 and remove load side power jumpers [black wires])

ITEM NO.	PART NUMBER	DESCRIPTION
12	52429-80	Transformer Fuse Holder
13*	PA7330	Transformer Fuse
14*	PA6496	Relay, Brake Control (BC)
15*	PA6254	Relay, Brake Control (BR)
16*	86712	Brake Circuit Control Board
17	52429-07	Transformer, 250 VA, 200-115
	52429-19	Transformer, 250 VA, 230/460-115
	52429-42	Transformer, 250 VA, 575-115
18*	PA7382	Relay, High Speed
19	PA7384	Relay, Socket, Plug in
20	PA7385	Relay Hold Down Clips
Not Shown	86733-01	Mainline Contactor, (optional)
	86737-10	Aux. Contact Block, (optional)
Not Shown	69505-02	Danger Label, Electrical

\*Recommended Spare Parts

# PARTS LIST - PRODUCT SERIES 32

## BASIC CONTROL COMPONENTS

SINGLE AND TWO SPEED CONTROL COMBINATIONS, AND CONTROLS WITH TROLLEY ACM

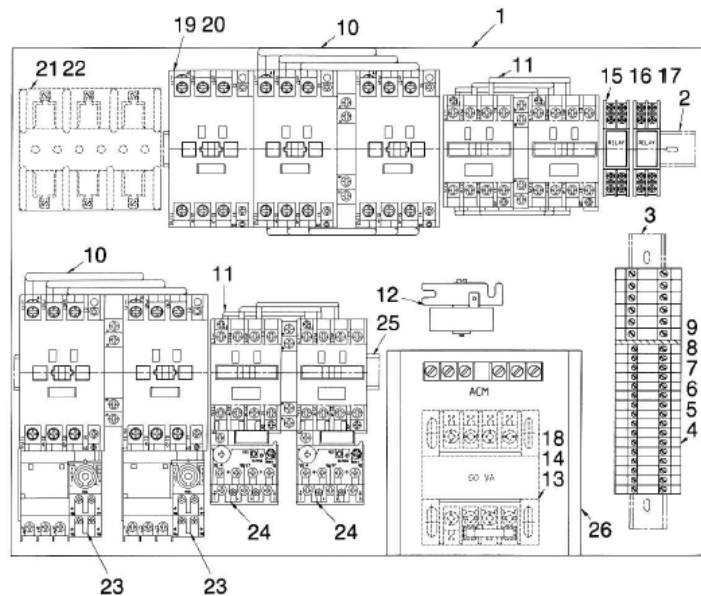

### REPLACEMENT PARTS

ITEM NO.	PART NUMBER	DESCRIPTION
1	86823	Panel, Drilled
2	86714-11	DIN Rail, Pre-cut, 13"
3	86714-03	DIN Rail, Pre-cut, 9-1/2"
4	86710-04	Terminal, Grounding
5	86710-05	Terminal, End Anchor
6	86710-06	Terminal, End Barrier, Power
7	86710-07	Terminal, End Barrier, Control
8	86710-01	Terminal, Control
9	86710-02	Terminal, Power
10*	86729-01	Contact, Reversing, (or Two Speed) 115 V (Hoist) For Two Speed Contactor remove load side jumper wires (black wires)
	86729-02	Contact, Reversing, (or Two Speed) 24 V (Hoist) For Two Speed Contactor remove load side jumper wires (black wires)
11*	86727-01	Contact, Reversing, (or Two Speed) 115 V (Trolley) For Two Speed Contactor remove load side jumper wires (black wires)
	86727-02	Contact, Reversing, (or Two Speed) 24 V (Trolley) For Two Speed Contactor remove load side jumper wires (black wires)
12	PA7103	Time Capsule, 115 V (Two Speed Only)
	PA7104	Time Capsule, 24 V (Two Speed Only)
13	52429-80	Transformer Fuse Clip (24 V Models Only)
14*	PA7330	Transformer Fuse (24 V Models Only)
15*	PA7382	Relay, Control, 115 V (Two Speed Only)
	PA7383	Relay, Control, 24 V (Two Speed Only)

ITEM NO.	PART NUMBER	DESCRIPTION
16	PA7384	Relay, Socket
17	PA7385	Relay, Retainer Clip
18*	53429-XX	Transformer (24 V controls only) -52 for 200 V; -26 for 230/460 V; -64 for 575 V Supply
19*	86733-01	Mainline Contactor, 115 V (Optional)
	86733-02	Mainline Contactor, 24 V (Optional)
20	86737-10	Contact Block, Aux. (used with Mainline Contactor)
21*	PA7341	Fuse Block, Mtr. Ckt. 30A. (Optional)
	PA7342	Fuse Block, Mtr. Ckt. 60A. (Optional)
22*	86709-XX	Fuse, Mtr. Ckt. (Optional) see note below
23	86736-XX	Overload Relay, Hoist (Optional) see note below
24	86736-XX	Overload Relay, Trolley (Optional) see note below
25	86714-02	DIN Rail, Pre-cut, 8"
26	86715-017	ACM, S.S., 1 H.P. Max. 200-230 V, 2 H.P. Max. 460 V
	86715-019	ACM, S.S., 2.5 H.P. Max. 200-230 V, 5 H.P. Max. 460 V
	86715-018	ACM, 2S., 1 H.P. Max. 200-230 V, 2 H.P. Max. 460 V
	86715-020	ACM, 2S., 2.5 Max. H.P. 200-230 V, 5 H.P. Max. 460 V
	86715-002	ACM, S.S., 2 H.P. Max. 575 V
	86715-004	ACM, S.S., 5 H.P. Max. 575 V
	86715-006	ACM, 2S., 2 H.P. Max. 575 V
	86715-008	ACM, 2S., 5 H.P. Max. 575 V
Not Shown	69505-02	Danger Label, Electrical

\*Recommended Spare Parts

### NOTE:

When ordering Motor Circuit Fuses or Overload Relays, provide as much information about the hoist as possible. Hoist serial number, motor H.P.'s, full load currents, supply voltage, etc. ACM's listed are for 115 V control only. For 24 V control, order by description.

# PARTS LIST - PRODUCT SERIES 32

## BASIC CONTROL COMPONENTS

SINGLE AND TWO SPEED CONTROL COMBINATIONS, WITH TROLLEY ACM, AND 24 V CONTROL VOLTAGE

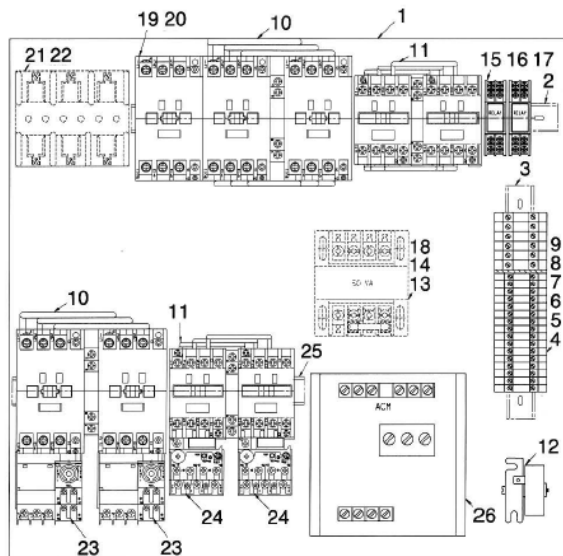

### REPLACEMENT PARTS

ITEM NO.	PART NUMBER	DESCRIPTION
1	86824	Panel, Drilled
2	86714-11	DIN Rail, Pre-cut, 13"
3	86714-03	DIN Rail, Pre-cut, 9-1/2"
4	86710-04	Terminal, Grounding
5	86710-05	Terminal, End Anchor
6	86710-06	Terminal, End Barrier, Power
7	86710-07	Terminal, End Barrier, Control
8	86710-01	Terminal, Control
9	86710-02	Terminal, Power
10*	86729-01	Contact, Reversing, (or Two Speed) 115V (Hoist) For Two Speed Contactor remove load side jumper wires (black wires)
	86729-02	Contact, Reversing, (or Two Speed) 24V (Hoist) For Two Speed Contactor remove load side jumper wires (black wires)
11*	86727-01	Contact, Reversing, (or Two Speed) 115V (Trolley) For Two Speed Contactor remove load side jumper wires (black wires)
	86727-02	Contact, Reversing, (or Two Speed) 24V (Trolley) For Two Speed Contactor remove load side jumper wires (black wires)
12	PA7103	Time Capsule, 115 V (Two Speed Only)
	PA7104	Time Capsule, 24 V (Two Speed Only)
13	52429-80	Transformer Fuse Clip (24 V Models Only)
14*	PA7330	Transformer Fuse (24 V Models Only)
15*	PA7382	Relay, Control, 115 V (Two Speed Only)
	PA7383	Relay, Control, 24 V (Two Speed Only)

ITEM NO.	PART NUMBER	DESCRIPTION
16	PA7384	Relay, Socket
17	PA7385	Relay, Retainer Clip
18*	52429-XX	Transformer (24 V controls only) -52 for 200 V; -26 for 230/460 V; -64 for 575 V Supply
19*	86733-01	Mainline Contactor, 115 V (Optional)
	86733-02	Mainline Contactor, 24 V (Optional)
20	86737-10	Contact Block, Aux. (used with Mainline Contactor)
21*	PA7341	Fuse Block, Mtr. Ckt. 30A. (Optional)
	PA7342	Fuse Block, Mtr. Ckt. 60A. (Optional)
22*	86709-XX	Fuse, Mtr. Ckt. (Optional) see note below
23	86736-XX	Overload Relay, Hoist (Optional) see note below
24	86736-XX	Overload Relay, Trolley (Optional) see note below
25	86714-02	DIN Rail, Pre-cut, 8"
26	86715-017	ACM, S.S., 1 H.P. Max. 200-230 V, 2 H.P. Max. 460 V
	86715-019	ACM, S.S., 2.5 H.P. Max. 200-230 V, 5 H.P. Max. 460 V
	86715-018	ACM, 2S., 1 H.P. Max. 200-230 V, 2 H.P. Max. 460 V
	86715-020	ACM, 2S., 2.5 Max. H.P. 200-230 V, 5 H.P. Max. 460 V
	86715-002	ACM, S.S., 2 H.P. Max. 575 V
	86715-004	ACM, S.S., 5 H.P. Max. 575 V
	86715-006	ACM, 2S., 2 H.P. Max. 575 V
	86715-008	ACM, 2S., 5 H.P. Max. 575 V
Not Shown	69505-02	Danger Label, Electrical

\*Recommended Spare Parts

### NOTE:

When ordering Motor Circuit Fuses or Overload Relays, provide as much information about the hoist as possible. Hoist serial number, motor H.P.'s, full load currents, supply voltage, etc. ACM's listed are for 115 V control only. For 24 V control, order by description.

# PARTS LIST - PRODUCT SERIES 32

## PENDANT CONTROL STATION

### PENDANT CONTROL STATION PARTS LIST

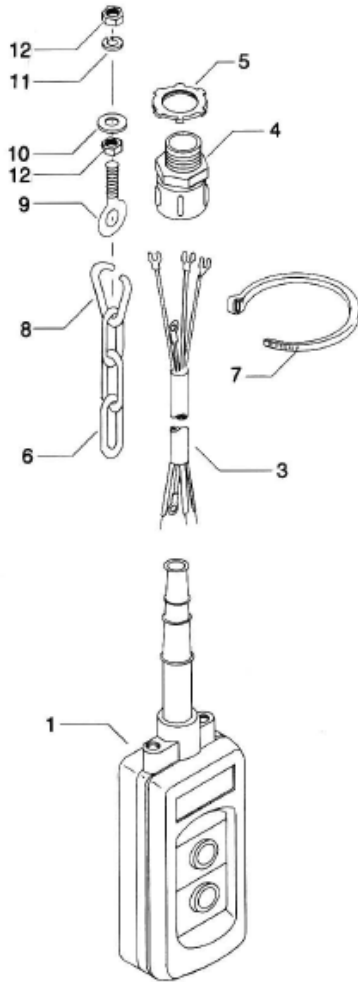

PUSHBUTTON STATION

ITEM NO.	PART NUMBER	DESCRIPTION
1	68898-01	2-Button, Single Speed Pushbutton Station Assembly
	68898-02	2-Button, Two Speed Pushbutton Station Assembly
	86718-02	4-Button, Pushbutton Station, Enclosure only
	86718-03	6-Button, Pushbutton Station Enclosure only
	86718-04	8-Button, Pushbutton Station Enclosure only
2	86718-16	Single Speed Contact Block (not shown)
	86718-19	Two Speed Contact Block (not shown)
	86718-05	Operator Button (Black)
	86718-06	Operator Button (Green)
	86718-07	Operator Button (Red)
3	62046	Cable, 16 Awg., 4 Cond.
	PA2513	Cable, 16 Awg., 8 Cond.
	PA2514	Cable, 16 Awg., 14 Cond.
4	PA2427	Cable Grip, 4 Cond. Cable
	PA2145	Cable Grip, 8 Cond. Cable
	PA2517	Cable Grip, 14 Cond. Cable
5	PA1827	Locknut for PA2427 & PA2145
	PA2036	Locknut for PA2517
6	PA2034	Strain Relief Chain
7	PA6750	Self-Locking Tie
8	PA2035	Chain Repair Link
9	PA5037	Eye Bolt
10	15-4-2C	Washer
11	17-4C	Lockwasher
12	22-4C	Nut
13	63178-01	Warning Label



WARNING LABEL  
63178-01  
Replace Label  
If Lost or Illegible

#### NOTE:

When ordering pushbutton control cable or strain relief chain, specify length in feet. When specifying length of control cable, allow sufficient length to make connections inside of pushbutton station and control enclosure.

# PARTS LIST - PRODUCT SERIES 32

## PENDANT CONTROL STATION

### PENDANT CONTROL STATION PARTS LIST

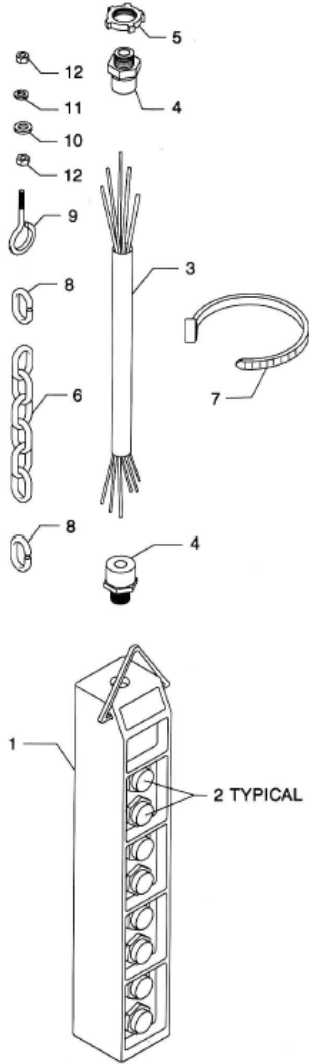

PUSHBUTTON STATION

ITEM NO.	PART NUMBER	DESCRIPTION
1	86716-01	2-Button Enclosure
	86716-02	4-Button Enclosure
	86716-03	6-Button Enclosure
	86716-04	8-Button Enclosure
	86716-05	10-Button Enclosure
2	86716-06	Single Speed Button Assy.
	86716-07	Two Speed Button Assy.
	86716-08	Three Speed Button Assy.
	86716-09	Five Speed Button Assy.
	86716-10	On Button (Green)
	86716-11	Off Button (Red)
	86716-12	Pilot Light (Red)
	86716-13	Two Position Maint. Selector Switch
	86716-14	Three Position Maint. Selector Switch
	86716-15	Push - Pull Operator (Maint.)
	86716-16	Red Mushroom Head Operator (Momentary)
	86716-17	Two Position Keylock Selector (Maint.)
	86716-18	2-Button Maint. Operator (Interlocked)
86716-19	Contact Block (1 N.O. & 1 N.C.)	
86716-20	Closing Button (For Unused Holes)	
86716-21	P.B. Operator (Black, 1 N.O. & 1 N.C.)	
3	62046	Cable, 16 AWG., 4 Cond.
	PA2513	Cable, 16 AWG. 8 Cond.
	PA2514	Cable, 16 AWG., 14 Cond.
	PA6706	Cable, 16 AWG., 24 Cond.
4	PA2427	Cable Grip, 4 Cond. Cable
	PA6652	Cable Grip, 8 Cond. Cable
	PA2517	Cable Grip, 14 Cond. Cable
	PA6705	Cable Grip, 24 Cond. Cable
5	PA1827	Locknut for PA2427 & PA6652
	PA2036	Locknut for PA2517
	PA1828	Locknut for PA6705
6	PA2034	Strain Relief Chain
7	PA6750	Self Locking Tie
8	PA2035	Chain Repair Link
9	PA5037	Eye Bolt
10	15-4-2C	Washer
11	17-4C	Lockwasher
12	22-4C	Nut
13	63178-01	Warning Label



WARNING LABEL  
63178-01  
Replace Label  
If Lost or Illegible

**NOTE:** When ordering pushbutton control cable or strain relief chain, specify length in feet. When specifying length of control cable, allow sufficient length to make connections inside of pushbutton station and control enclosure.

# PARTS LIST - PRODUCT SERIES 32

## 2-WHEEL PLAIN TROLLEY ASSEMBLY 4 IN. DIAMETER WHEEL - NON-SWIVELING - TWO MOUNTING STUDS

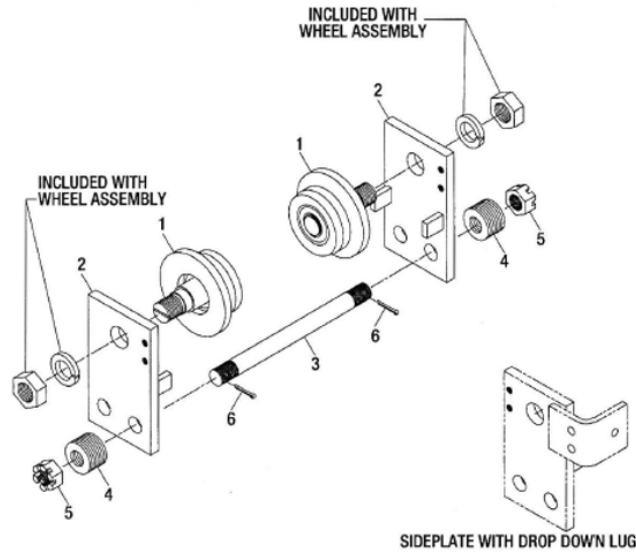

### TROLLEY PARTS - 4" DIAMETER WHEELS

TROLLEY ASSEMBLY	BEAM FLANGE WIDTH (Inches)	DROP DOWN LUGS	WHEEL ASSEMBLY		SIDEPLATE	SIDEPLATE	STUD	WASHER		NUT	COTTER PIN
			2 PER TROLLEY		1 PER TROLLEY	1 PER TROLLEY	2 PER TROLLEY			4 PER TROLLEY	4 PER TROLLEY
			MATL.	ITEM 1	ITEM 2	ITEM 2	ITEM 3	QTY/TRLY	ITEM 4	ITEM 5	ITEM 6
69824-01	3-1/4 to 5	No	Steel Dual Tread	69810-01	69818-01	69818-01	69812-01	36	15-16-1C	26-16	PA1501
69824-02	5-1/8 to 8				69812-02	80					
69824-03	8-1/8 to 10-1/2				69821-01	69821-01	69812-03	44			
69824-23	10-5/8 to 12-1/2				69821-04	69821-04	69812-04				
69824-24	12-5/8 to 14				69821-07	69821-07	69812-05				
69824-04	3-1/4 to 5		Bronze Dual Tread	69810-02	69818-01	69818-01	69812-01	36			
69824-05	5-1/8 to 8				69812-02	80					
69824-06	8-1/8 to 10-1/2				69821-01	69821-01	69812-03	44			
69824-25	10-5/8 to 12-1/2				69821-04	69821-04	69812-04				
69824-26	12-5/8 to 14				69821-07	69821-07	69812-05				
69824-07	3-1/4 to 5	Yes	Steel Dual Tread	69810-01	69818-02	69818-03	69812-01	36			
69824-08	5-1/8 to 8				69812-02	80					
69824-09	8-1/8 to 10-1/2				69821-02	69821-03	69812-03	44			
69824-29	10-5/8 to 12-1/2				69821-05	69821-06	69812-04				
69824-30	12-5/8 to 14		69821-08	69821-09	69812-05						
69824-10	3-1/4 to 5		Bronze Dual Tread	69810-02	69818-02	69818-03	69812-01	36			
69824-11	5-1/8 to 8				69812-02	80					
69824-12	8-1/8 to 10-1/2				69821-02	69821-03	69812-03	44			
69824-31	10-5/8 to 12-1/2	69821-05			69821-06	69812-04					
69824-32	12-5/8 to 14	69821-08	69821-09	69812-05							
69824-13	3-1/4 to 5 (a)	No	Steel Flat	69888-01	69818-01	69818-01	69812-01	36			
69824-14	3-1/4 to 5 (a)		Bronze Flat	69888-02							
69824-15	3-1/4 to 5 (a)	Yes	Steel Flat	69888-01	69818-02	69818-03					
69824-16	3-1/4 to 5 (a)		Bronze Flat	69888-02							

No Recommended Spare Parts

**NOTE:** (a) For operation on patented monorail track.

# PARTS LIST - PRODUCT SERIES 32

## 4-WHEEL PLAIN TROLLEY ASSEMBLY 4 IN. DIAMETER WHEEL - NON-SWIVELING - ONE MOUNTING STUD

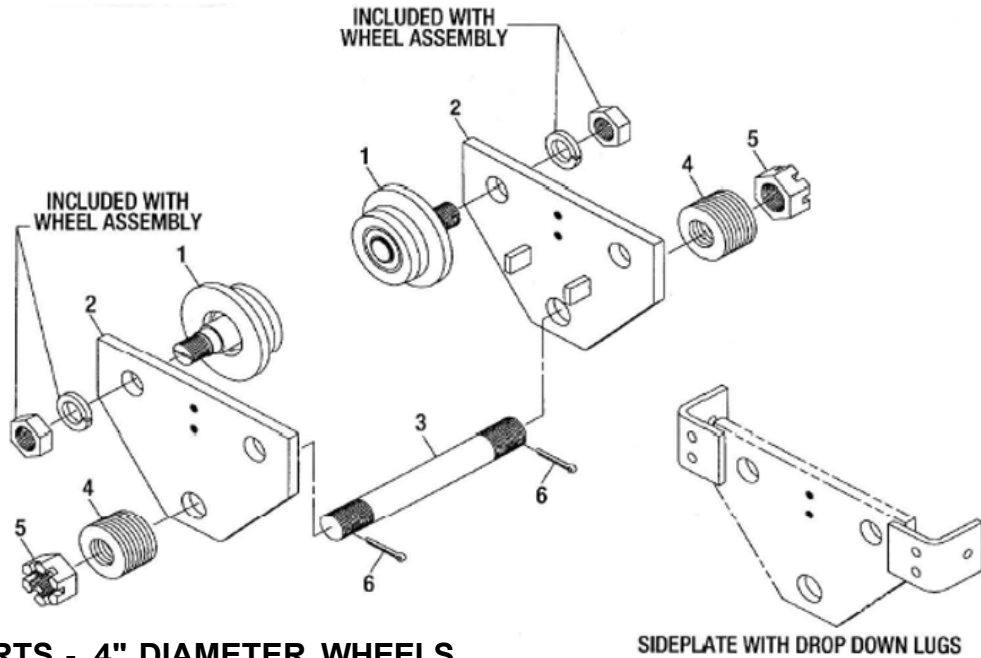

### TROLLEY PARTS - 4" DIAMETER WHEELS

TROLLEY ASSEMBLY	BEAM FLANGE WIDTH (Inches)	DROP DOWN LUGS	WHEEL ASSEMBLY		SIDEPLATE	STUD	WASHER		NUT	COTTER PIN		
			4 PER TROLLEY		2 PER TROLLEY	1 PER TROLLEY			2 PER TROLLEY	2 PER TROLLEY		
			MATL.	ITEM 1	ITEM 2	ITEM 3	QTY/TRLY	ITEM 4	ITEM 5	ITEM 6		
69822-01	3-1/4 to 5	No	Steel Dual Tread	69810-01	69814-01	69767-01	14	PA6932	26-24	PA1355		
69822-02	5-1/8 to 8					69767-02					30	
69822-03	8-1/8 to 10-1/2					69819-01					69767-03	16
69822-23	10-5/8 to 12-1/2					69819-03					69767-04	
69822-24	12-5/8 to 14					69819-05					69767-05	
69822-04	3-1/4 to 5		Bronze Dual Tread	69810-02	69814-01	69767-01	14					
69822-05	5-1/8 to 8					69767-02					30	
69822-06	8-1/8 to 10-1/2					69819-01					69767-03	16
69822-25	10-5/8 to 12-1/2					69819-03					69767-04	
69822-26	12-5/8 to 14					69819-05					69767-05	
69822-07	3-1/4 to 5	Yes	Steel Dual Tread	69810-01	69814-02	69767-01	14					
69822-08	5-1/8 to 8					69767-02		30				
69822-09	8-1/8 to 10-1/2					69819-02		69767-03	16			
69822-29	10-5/8 to 12-1/2					69819-04		69767-04				
69822-30	12-5/8 to 14					69819-06		69767-05				
69822-10	3-1/4 to 5		Bronze Dual Tread	69810-02	69814-02	69767-01	14					
69822-11	5-1/8 to 8					69767-02		30				
69822-12	8-1/8 to 10-1/2					69819-02		69767-03	16			
69822-31	10-5/8 to 12-1/2					69819-04		69767-04				
69822-32	12-5/8 to 14					69819-06		69767-05				
69822-13	3-1/4 to 5 (a)	No	Steel Flat	69888-01	69814-01	69767-01	14					
69822-14	3-1/4 to 5 (a)		Bronze Flat	69888-02								
69822-15	3-1/4 to 5 (a)	Yes	Steel Flat	69888-01	69814-02							
69822-16	3-1/4 to 5 (a)		Bronze Flat	69888-02								

No Recommended Spare Parts

**NOTE:** (a) For operation on patented monorail track.

# PARTS LIST - PRODUCT SERIES 32

## 4-WHEEL GEARED TROLLEY ASSEMBLY 4 IN. DIAMETER WHEEL - NON-SWIVELING - ONE MOUNTING STUD

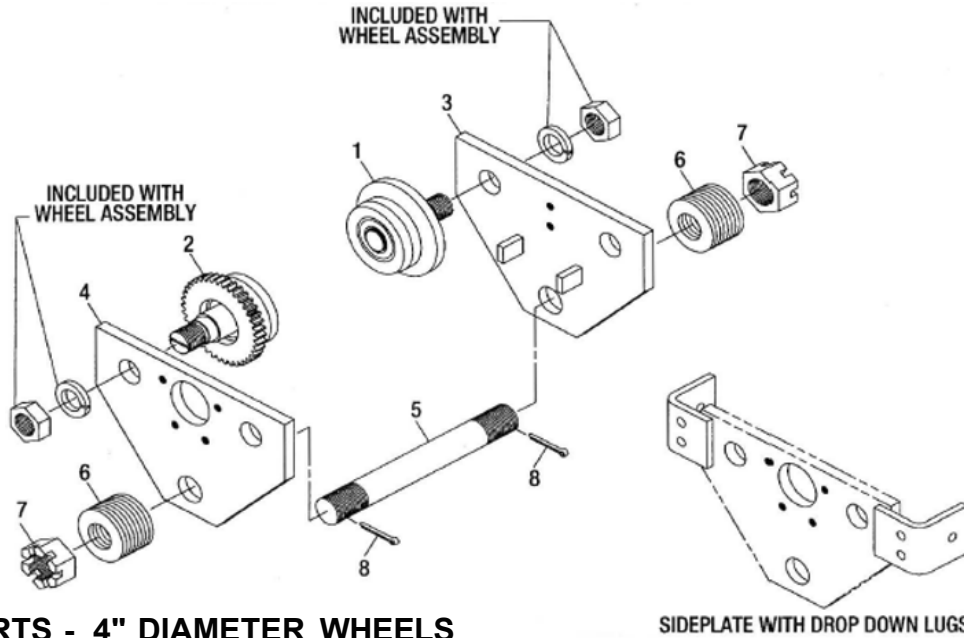

### TROLLEY PARTS - 4" DIAMETER WHEELS

TROLLEY ASSEMBLY	BEAM FLANGE WIDTH (Inches)	DROP DOWN LUGS	WHEEL ASSEMBLY			SIDEPLATE	SIDEPLATE	STUD	WASHER		NUT	COTTER PIN
			2 EACH PER TROLLEY			1 PER TROLLEY	1 PER TROLLEY	1 PER TROLLEY			2 PER TROLLEY	2 PER TROLLEY
			MATL.	PLAIN ITEM 1	GEARED ITEM 2	ITEM 3	ITEM 4	ITEM 5	QTY/ TRLY	ITEM 6	ITEM 7	ITEM 8
69823-01	3-1/4 to 5	No	Steel Dual Tread	69810-01	69811-01	69814-01	69815-01	69767-01	14	PA6932	26-24	PA1355
69823-02	5-1/8 to 8							69767-02	30			
69823-03	8-1/8 to 10-1/2							69819-01	69820-01			
69823-23	10-5/8 to 12-1/2					69767-04						
69823-24	12-5/8 to 14					69819-05	69820-05	69767-05				
69823-04	3-1/4 to 5		Bronze Dual Tread	69810-02	69811-02	69814-01	69815-01	69767-01	14			
69823-05	5-1/8 to 8							69767-02	30			
69823-06	8-1/8 to 10-1/2							69819-01	69820-01			
69823-25	10-5/8 to 12-1/2					69767-04						
69823-26	12-5/8 to 14	69819-05				69820-05	69767-05					
69823-07	3-1/4 to 5	Yes	Steel Dual Tread	69810-01	69811-01	69814-02	69815-02	69767-01	14			
69823-08	5-1/8 to 8							69767-02	30			
69823-09	8-1/8 to 10-1/2							69819-02	69820-02			
69823-29	10-5/8 to 12-1/2					69767-04						
69823-30	12-5/8 to 14					69819-06	69820-06	69767-05				
69823-10	3-1/4 to 5		Bronze Dual Tread	69810-02	69811-02	69814-02	69815-02	69767-01	14			
69823-11	5-1/8 to 8							69767-02	30			
69823-12	8-1/8 to 10-1/2							69819-02	69820-02	69767-03	16	
69823-31	10-5/8 to 12-1/2					69767-04						
69823-32	12-5/8 to 14	69819-06				69820-06	69767-05					
69823-13	3-1/4 to 5 (a)	No	Steel Flat	69888-01	69889-01	69814-01	69815-01	69767-01	14			
69823-14	3-1/4 to 5 (a)		Bronze Flat	69888-02	69889-02							
69823-15	3-1/4 to 5 (a)		Yes	Steel Flat	69888-01	69889-01	69814-02			69815-02		
69823-16	3-1/4 to 5 (a)			Bronze Flat	69888-02	69889-02						

No Recommended Spare Parts

**NOTE:** (a) For operation on patented monorail track.

# PARTS LIST - PRODUCT SERIES 32

## 4-WHEEL GEARED TROLLEY ASSEMBLY DUAL DRIVE 4 IN. DIAMETER WHEEL - NON-SWIVELING - ONE MOUNTING STUD

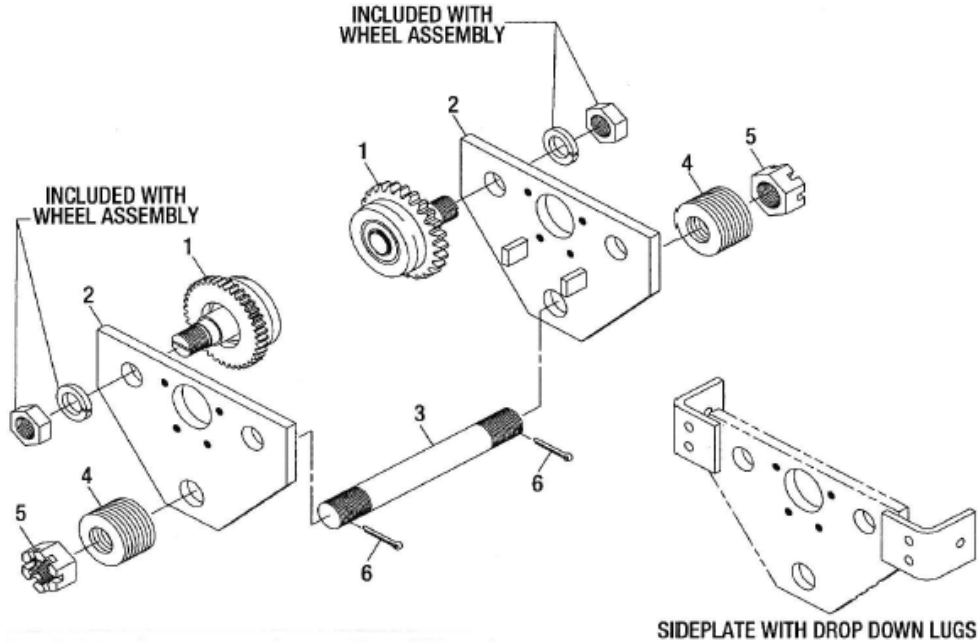

### TROLLEY PARTS - 4" DIAMETER WHEELS

TROLLEY ASSEMBLY	BEAM FLANGE WIDTH (Inches)	DROP DOWN LUGS	WHEEL ASSEMBLY		SIDEPLATE	STUD	WASHER		NUT	COTTER PIN
			4 PER TROLLEY		2 PER TROLLEY	1 PER TROLLEY			2 PER TROLLEY	2 PER TROLLEY
			MATL.	ITEM 1	ITEM 2	ITEM 3	QTY/TRLY	ITEM 4	ITEM 5	ITEM 6
70866-01	3-1/4 to 5	No	Steel Dual Tread	69811-01	69815-01	69767-01	14	PA6932	26-24	PA1355
70866-02	5-1/8 to 8				69820-01	69767-02	30			
70866-03	8-1/8 to 10-1/2				69820-03	69767-03	16			
70866-23	10-5/8 to 12-1/2				69820-05	69767-04				
70866-24	12-5/8 to 14				69767-05					
70866-04	3-1/4 to 5		Bronze Dual Tread	69811-02	69815-01	69767-01	14			
70866-05	5-1/8 to 8				69820-01	69767-02	30			
70866-06	8-1/8 to 10-1/2				69820-03	69767-03	16			
70866-25	10-5/8 to 12-1/2				69820-05	69767-04				
70866-26	12-5/8 to 14				69767-05					
70866-07	3-1/4 to 5	Steel Dual Tread	69811-01	69815-02	69767-01	14				
70866-08	5-1/8 to 8			69820-02	69767-02	30				
70866-09	8-1/8 to 10-1/2			69820-04	69767-03	16				
70866-29	10-5/8 to 12-1/2			69820-06	69767-04					
70866-30	12-5/8 to 14			69767-05						
70866-10	3-1/4 to 5			Bronze Dual Tread	69811-02	69815-02	69767-01			
70866-11	5-1/8 to 8	69820-02	69767-02			30				
70866-12	8-1/8 to 10-1/2	69820-04	69767-03			16				
70866-31	10-5/8 to 12-1/2	69820-06	69767-04							
70866-32	12-5/8 to 14	69767-05								
70866-13	3-1/4 to 5 (a)	No	Steel Flat			69889-01	69815-01	69767-01	14	
70866-14	3-1/4 to 5 (a)		Bronze Flat	69889-02						
70866-15	3-1/4 to 5 (a)	Yes	Steel Flat	69889-01	69815-02					
70866-16	3-1/4 to 5 (a)		Bronze Flat	69889-02						

No Recommended Spare Parts

**NOTE:** (a) For operation on patented monorail track.

**THIS PAGE INTENTIONALLY  
LEFT BLANK**

# PARTS LIST - PRODUCT SERIES 32

## 4-WHEEL PLAIN TROLLEY ASSEMBLY 5 IN. DIAMETER WHEEL - NON-SWIVELING - TWO MOUNTING STUDS

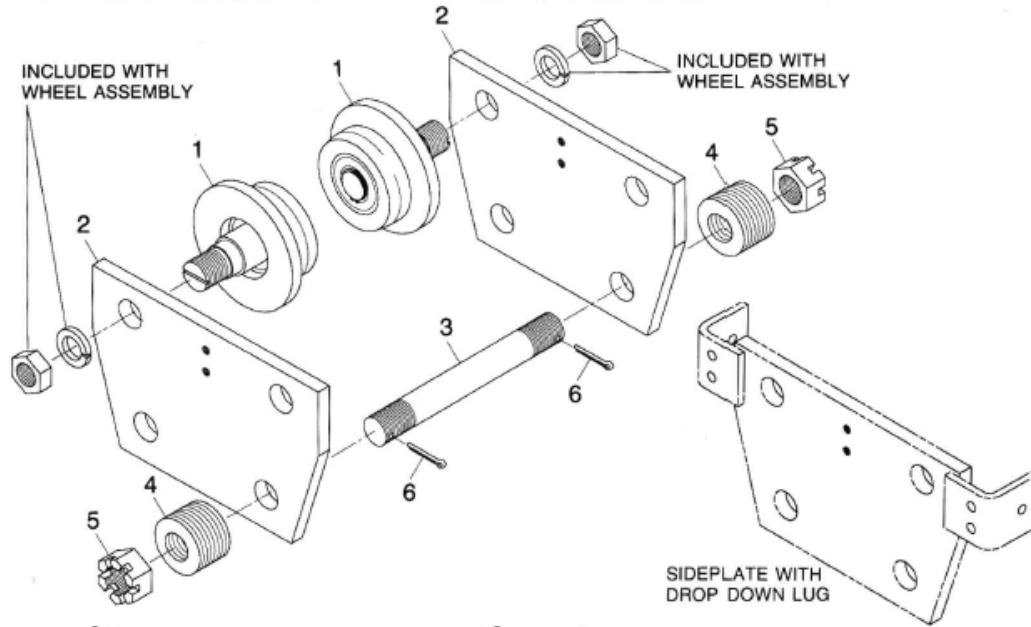

### TROLLEY PARTS - 5" DIAMETER WHEELS

TROLLEY ASSEMBLY	BEAM FLANGE WIDTH (Inches)	DROP DOWN LUGS	WHEEL ASSEMBLY		SIDEPLATE	STUD	WASHER		NUT	COTTER PIN		
			4 PER TROLLEY		2 PER TROLLEY	2 PER TROLLEY	QTY/TRLY	ITEM 4	4 PER TROLLEY	4 PER TROLLEY		
			MATL.	ITEM 1	ITEM 2	ITEM 3			ITEM 5	ITEM 6		
69769-01	4 to 5	No	Steel Dual Tread	69789-01	69762-01	69767-01	28	PA6932	26-24	PA1355		
69769-02	5-1/8 to 8					69767-02					60	
69769-03	8-1/8 to 10-1/2					69784-01					69767-03	32
69769-17	10-5/8 to 12-1/2					69784-03					69767-04	
69769-18	12-5/8 to 14					69784-05					69767-05	
69769-04	4 to 5		Bronze Dual Tread	69789-02	69762-01	69767-01	28					
69769-05	5-1/8 to 8					69767-02	60					
69769-06	8-1/8 to 10-1/2					69784-01	69767-03				32	
69769-19	10-5/8 to 12-1/2					69784-03	69767-04					
69769-20	12-5/8 to 14					69784-05	69767-05					
69769-07	4 to 5	Yes	Steel Dual Tread	69789-01	69762-02	69767-01	28					
69769-08	5-1/8 to 8					69767-02	60					
69769-09	8-1/8 to 10-1/2					69784-02	69767-03	32				
69769-21	10-5/8 to 12-1/2		69784-04	69767-04								
69769-22	12-5/8 to 14		69784-06	69767-05								
69769-10	4 to 5		Bronze Dual Tread	69789-02	69762-02	69767-01	28					
69769-11	5-1/8 to 8	69767-02				60						
69769-12	8-1/8 to 10-1/2	69784-02				69767-03	32					
69769-23	10-5/8 to 12-1/2	69784-04	69767-04									
69769-24	12-5/8 to 14	69784-06	69767-05									
69769-13	3-1/4 to 5 (a)	No	Steel Flat	69895-01	69762-01	69767-01	28					
69769-14	3-1/4 to 5 (a)	No	Bronze Flat	69895-02								
69769-15	3-1/4 to 5 (a)	Yes	Steel Flat	69895-01	69762-02							
69769-16	3-1/4 to 5 (a)		Bronze Flat	69895-02								

No Recommended Spare Parts

**NOTE:** (a) For operation on patented monorail track.

# PARTS LIST - PRODUCT SERIES 32

## 4-WHEEL GEARED TROLLEY ASSEMBLY 5 IN. DIAMETER WHEEL - NON-SWIVELING - TWO MOUNTING STUDS

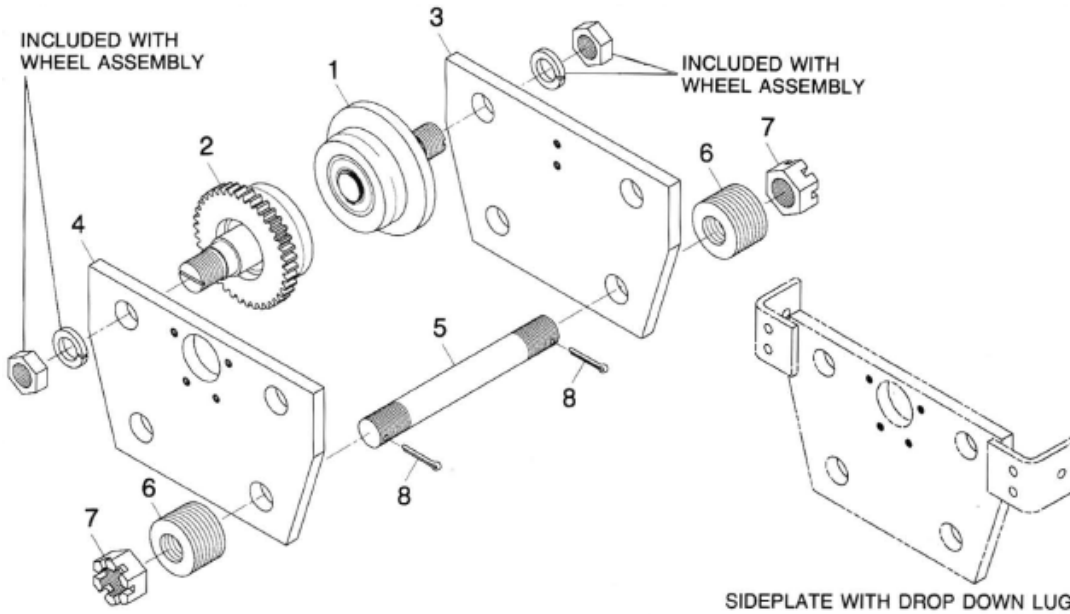

### TROLLEY PARTS - 5" DIAMETER WHEELS

TROLLEY ASSEMBLY	BEAM FLANGE WIDTH (Inches)	DROP DOWN LUGS	WHEEL ASSEMBLY			SIDEPLATE	SIDEPLATE	STUD	WASHER		NUT	COTTER PIN		
			2 EACH PER TROLLEY			1 PER TROLLEY	1 PER TROLLEY	2 PER TROLLEY	QTY/ TRLY	ITEM 6	2 PER TROLLEY	2 PER TROLLEY		
			MATL.	PLAIN ITEM 1	GEARED ITEM 2	ITEM 3	ITEM 4	ITEM 5			ITEM 7	ITEM 8		
69770-01	4 to 5	No	Steel Dual Tread	69789-01	69790-01	69762-01	69761-01	69767-01	28	PA6932	26-24	PA1355		
69770-02	5-1/8 to 8							69767-02	60					
69770-03	8-1/8 to 10-1/2							69784-01	69783-01				69767-03	32
69770-17	10-5/8 to 12-1/2							69784-03	69783-03				69767-04	
69770-18	12-5/8 to 14							69784-05	69783-05				69767-05	
69770-04	4 to 5		Bronze Dual Tread	69789-02	69790-02	69762-01	69761-01	69767-01	28					
69770-05	5-1/8 to 8							69767-02	60					
69770-06	8-1/8 to 10-1/2							69784-01	69783-01				69767-03	32
69770-19	10-5/8 to 12-1/2							69784-03	69783-03				69767-04	
69770-20	12-5/8 to 14							69784-05	69783-05				69767-05	
69770-07	4 to 5	Yes	Steel Dual Tread	69789-01	69790-01	69762-02	69761-02	69767-01	28					
69770-08	5-1/8 to 8							69767-02	60					
69770-09	8-1/8 to 10-1/2							69784-02	69783-02	69767-03	32			
69770-21	10-5/8 to 12-1/2		69784-04	69783-04	69767-04									
69770-22	12-5/8 to 14		69784-06	69783-06	69767-05									
69770-10	4 to 5		Bronze Dual Tread	69789-02	69790-02	69762-02	69761-02	69767-01	28					
69770-11	5-1/8 to 8	69767-02						60						
69770-12	8-1/8 to 10-1/2	69784-02						69783-02	69767-03	32				
69770-23	10-5/8 to 12-1/2	69784-04	69783-04	69767-04										
69770-24	12-5/8 to 14	69784-06	69783-06	69767-05										
69770-13	3-1/4 to 5 (a)	No	Steel Flat	69895-01	69896-01	69762-01	69761-01	69767-01	28					
69770-14	3-1/4 to 5 (a)		Bronze Flat	69895-02	69896-02									
69770-15	3-1/4 to 5 (a)	Yes	Steel Flat	69895-01	69896-01	69762-02	69761-02	69767-01	28					
69770-16	3-1/4 to 5 (a)		Bronze Flat	69895-02	69896-02									

No Recommended Spare Parts

**NOTE:** (a) For operation on patented monorail track.

# PARTS LIST - PRODUCT SERIES 32

## HAND-GEARED TROLLEY DRIVE PARALLEL MOUNTED HOIST

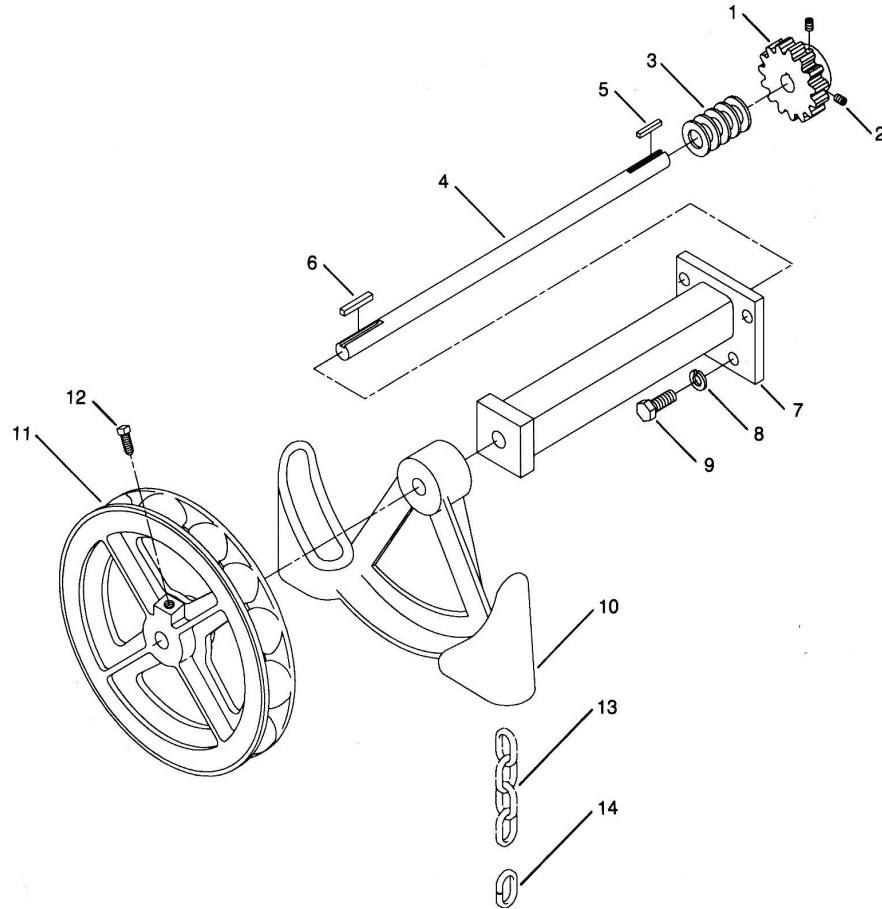

### HAND-GEARED TROLLEY DRIVE PARTS

ITEM NO.	PART NUMBER	DESCRIPTION	QTY
1	69788	Pinion 15T	1
2	12-5-4	Set Screw 5/16-18 x 1/4	2
3	15-12-1C	Washer	5
4	69798	Shaft	1
5	52674	Key 3/16 Sq.x1-1/4	1
6	PA6956	Key 1/4 Sq. x 1-5/8	1
7	69803	Bearing	1

ITEM NO.	PART NUMBER	DESCRIPTION	QTY
8	17-8C	Lockwasher 1/2	4
9	35-8-20C	Bolt 1/2-13x1-1/4	4
10	82143-1	Hand chain Guide	1
11	8464-4	Handwheel	1
12	14-6-16	Set Screw	1
13	(a)	Hand chain	1
14	(a)	Open Link	1

No Recommended Spare Parts

### NOTES:

- (a) When ordering hand chain, order Part Number (see below) and specify length.
- (b) Federal Specification QQ-Z-325, Type I, Class 3.
- (c) Federal Specification QQ-Z-325, Type I, Class 2.

TYPE OF TROLLEY	CHAIN MATERIAL	HANDCHAIN	OPEN LINK
Steel Wheels	Steel, Zinc Electro Plated (Acco Std) (b)	48158-1	60252-01
Steel Wheels	Steel, Zinc Electro Plated (c)	48158-11	60252-11
Bronze Wheels	Aluminum	48159-1	PA3985

# PARTS LIST - PRODUCT SERIES 32

## MOTORIZED TROLLEY DRIVE

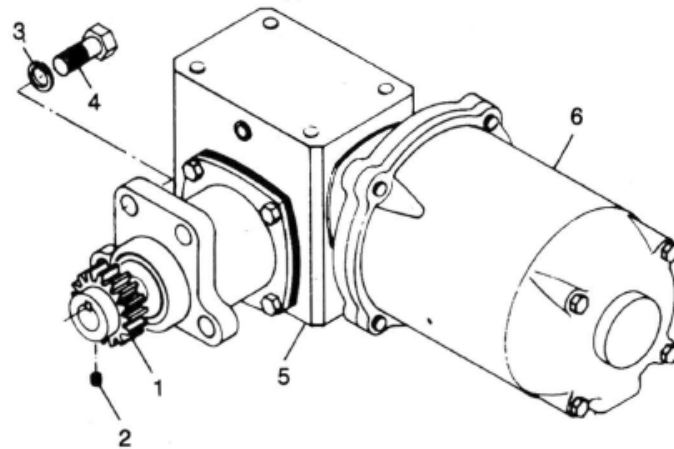

### MOTORIZED TROLLEY DRIVE PARTS

ITEM NO.	PART NO.	DESCRIPTION	MONORAIL TROLLEY QUANTITY	TOP-RUNNING TROLLEY QUANTITY
1	69788	Pinion (15 teeth)	1	0
	62214	Pinion (14 teeth)	0	1
2	12-5-4	Set Screw	2	0
	12-4-4C	Set Screw	0	2
3	17-8C	Lockwasher	4	4
4	35-8-20C	Hex Head Bolt	4	4
5	(a)	Right-Angle Gear Reducer	1	1
6	(b)	Motor	1	1
Not Shown	69807	EP Moly D Grease	(c)	(c)

No Recommended Spare Parts

### NOTES:

(a) Select right-angle gear reducer as specified from the following:

- Part No. 71056-4X, 20:1 Reduction, 50 FPM Monorail Trolley or 32 FPM Top-Running Trolley, (standard).
- Part No. 71056-2X, 10:1 Reduction, 100 FPM Monorail Trolley or 65 FPM Top-Running Trolley, (standard).
- Part No. 71056-0X, 5:1 Reduction, 125 FPM Top-Running Trolley, (standard).
- Part No. 71056-5X, 30:1 Reduction, 33 FPM Monorail Trolley, (non-standard).
- Part No. 71056-3X, 15:1 Reduction, 65 FPM Monorail Trolley, (non-standard).
- Part No. 71056-1X, 7.5:1 Reduction, 125 FPM Monorail Trolley, (non-standard).

**X** = Reducer Mounting Position Number 1, 2, 3 or 4. See Serial Record for position used. Complete the part number by inserting the position number in place of the 'X'.

(b) Trolley motor brake is optional on motorized right-angle gear reducer trolley drive. Motors for monorail trolley drive without motor brake have one shaft extension. Motors for monorail trolley drive with motor brake have two shaft extensions. Motors for top-running trolley drive with or without motor brake have one shaft extension. Select motor as specified from the following:

PART NO. MOTOR WITH ONE SHAFT EXT.	PART NO. MOTOR WITH TWO SHAFT EXT.	VOLTAGE	HP	RPM	SPEED	FRAME
61010-01	65818-04	200	1/2	1800	Single	56C
61010-02	65818-05	208/230/460				
61010-03	65818-06	575				
61010-04	65818-10	200				
61010-05	65818-11	208/230/460	1			
61010-06	65818-12	575				
61012-01	65819-01	200	1/2 / 1/6	1800/600	Two	
61012-02	65819-02	230				
61012-03	65819-03	460				
61012-04	65819-04	575				
61012-05	65819-09	200	1 / 1/3			
61012-06	65819-10	230				
61012-07	65819-11	460				
61012-08	65819-12	575				

For other specified special motors, refer to additional information pages supplied with manual.

(c) Exposed gears and pinions on trolleys are shipped from the factory without lubricant. Lyondell® EP Moly D Grease, packaged in a 4-ounce bottle container, is furnished with all hoists that have trolleys specified. Refer to LUBRICATION section of Manual 69833: Installation, Operation, and Maintenance Manual for WRIGHT® WORK-RATED® Wire Rope Electric Hoists. Additional containers of Lyondell® EP Moly D Grease, packaged in a 4-ounce bottle, can be obtained by ordering Acco/Harrington part no. 69807.

# PARTS LIST - PRODUCT SERIES 32

## MOTORIZED TROLLEY RIGHT-ANGLE GEAR REDUCER

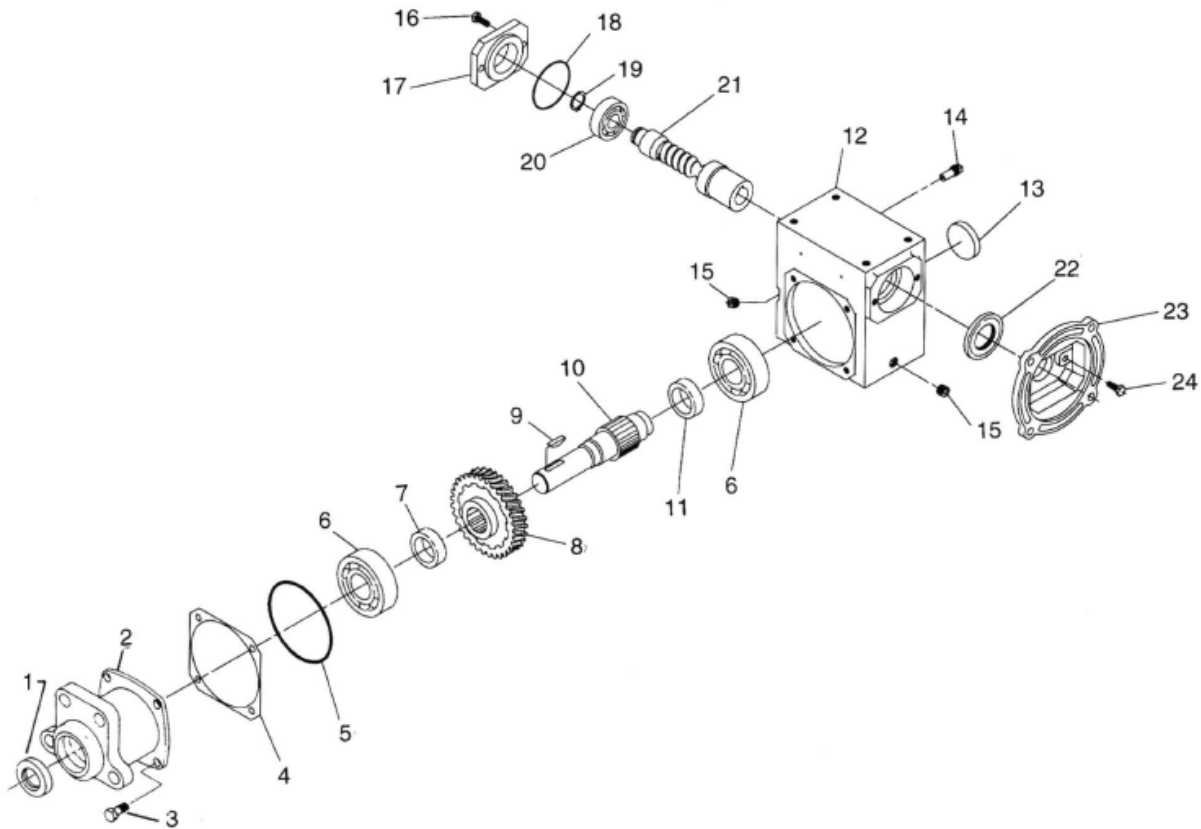

### RIGHT-ANGLE GEAR REDUCER PARTS

ITEM NO.	PART NUMBER	DESCRIPTION	QTY/ ASSY
1*	V93216A	Oil Seal	1
2	V28631C	Adapter	1
3	V91012A	Hex Head Cap Screw	4
4	VZ17T	Output Cover Shim	AR
5	V95769A	O-Ring	1
6	V40831	Output Bearing, Cone	2
	V40832	Output Bearing, Cup	2
7	VY17SG	Gear Spacer	1
8	VG17S05	Worm Gear 5:1	1
	VG17S07	Worm Gear 7.5:1	
	VG17S10	Worm Gear 10:1	
	VG17S15	Worm Gear 15:1	
	VG17S20	Worm Gear 20:1	
	VG17S30	Worm Gear 30:1	
9	V40267	Woodruff Key	1
10	VS17SGX01	Output Shaft	1
11	VY17SG	Gear Spacer	1
12	VH17SG	Gear Housing	1

ITEM NO.	PART NUMBER	DESCRIPTION	QTY/ ASSY
13	V93224A	Expansion Plug	1
14	V41752	Vent Plug	1
15	V40411	Pipe Plug	4
16	V91012A	Hex Head Cap Screw	2
17	VC13NB	Input Cover	1
18	V95771A	O-Ring	1
19	V41050	Retaining Ring	1
20	V40257	Input Bearing	1
21	V36086B	Quill Input Shaft 5:1	1
	V36530B	Quill Input Shaft 7.5:1	
	V36087B	Quill Input Shaft 10:1	
	V36088B	Quill Input Shaft 15:1	
	V36089B	Quill Input Shaft 20:1	
	V36091B	Quill Input Shaft 30:1	
22*	V93212A	Oil Seal	1
23	VF13Q56	Quill Motor Flange	1
24	V91012A	Hex Head Cap Screw	2

\*Recommended Spare Parts

#### NOTE:

Approximate capacity of oil bath is 1 pint. Refer to Lubrication section of Manual 69833.

# PARTS LIST - PRODUCT SERIES 32

## TROLLEY MOTOR BRAKE ASSEMBLY

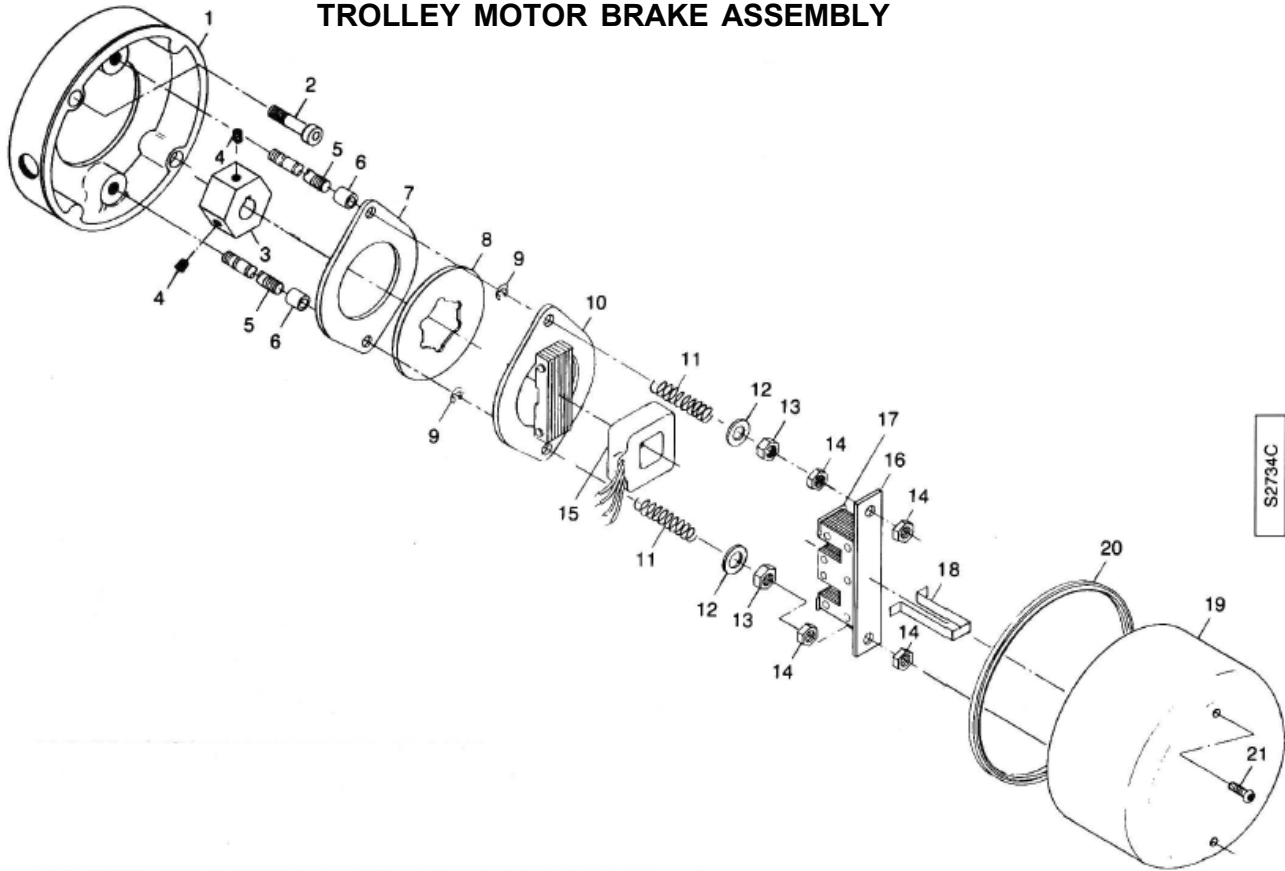

### TROLLEY MOTOR BRAKE PARTS

ITEM NO.	PART NUMBER	DESCRIPTION	QTY/ ASSY
1	65653	Adapter	1
2	1-6-24	Bolt, 3/8-16 x 1-1/2 lg	2
3	65654	Hub	1
4	12-4-6	Set Screw	2
5	65655	Stud	2
6	61459	Spacer	2
7	39794	Brake Plate	1
8*	39649	Brake Lining	1
9	PA5623	Retaining Ring	2
10	39781	Pressure Unit	1
11	PA5823	Spring	2
12	15-6-1	Flat Washer	2

ITEM NO.	PART NUMBER	DESCRIPTION	QTY/ ASSY
13	PA2377	Locknut	2
14	24-6	Jam Nut, 3/8	4
15*	39783-2 39783-3 39783-6	Coil 575 VAC 230/460 VAC 208 VAC	1
16	39780	Magnet Unit	1
17	39784	Shading Coil (a)	2
18	39877	Coil Strap	1
19	69161	Brake Cover	1
20	PA7110	Gasket	1.77ft
21*	PA7323	Screw, LOC-WEL, #10-24 (b)	2

\*Recommended Spare Parts

- (a) Shading Coil is furnished with Magnet Unit, but also available as a spare.
- (b) Screw with self-locking feature must be utilized. Substitutes are not permissible.
- (c) Trolley motor brake assembly shown on this page is the optional brake used on motorized right-angle gear reducer monorail trolley drives. For the optional brake used on motorized right-angle gear reducer top-running trolley drives, refer to additional information pages supplied with manual.

# PARTS LIST - PRODUCT SERIES 32

## DECK MOUNTED FRAME

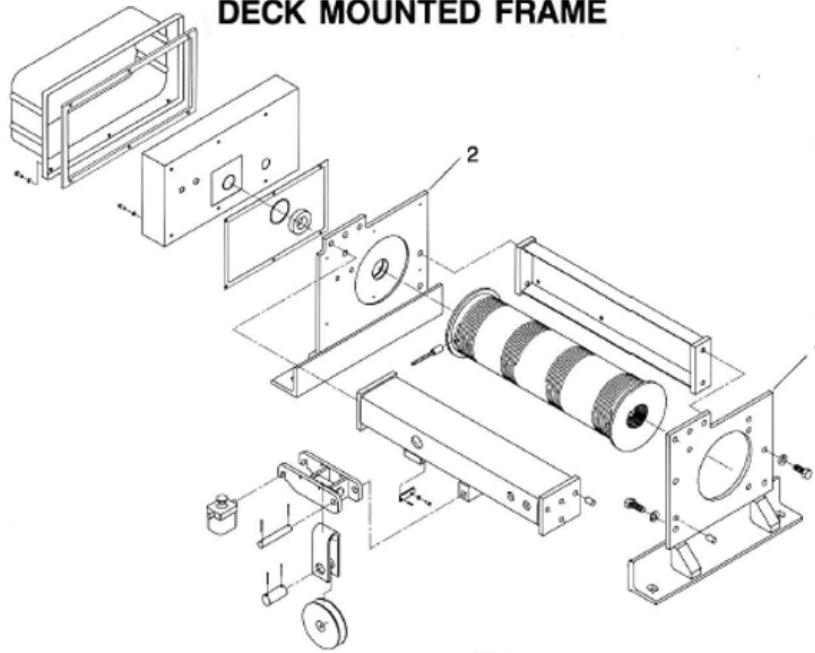

### DECK MOUNTED FRAME PARTS

ITEM NO.	DESCRIPTION	QUANTITY	PART NO.
1	End Plate, Deck Mounted Gear End	1	69849
2	End Plate, Deck Mounted Control End	1	69850

### Note:

For part numbers of other parts shown, refer to page 10 for 2PS reeving or page 11 for 2PD reeving.

No Recommended Spare Parts

## WINCH UNIT FRAME

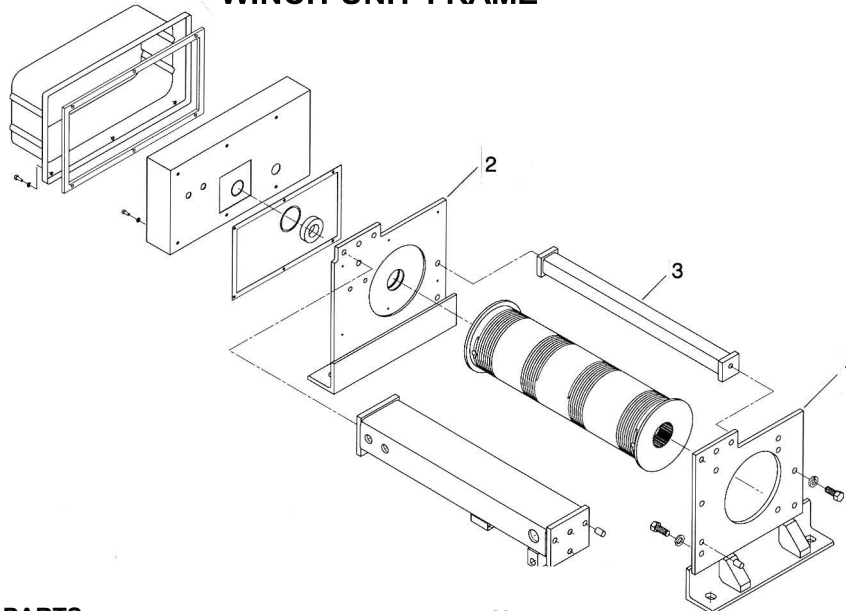

### WINCH UNIT FRAME PARTS

ITEM NO.	DESCRIPTION	QUANTITY	PART NO.
1	End Plate, Winch Gear End	1	69854
2	End Plate, Winch Control End	1	69855
3	Side Frame, Winch	1	(a)

### Notes:

For part numbers of other parts shown, refer to page 10 for 2PS reeving or page 11 for 2PD reeving.

(a) Winch side frame part number 69853-XX is available in various lengths. Contact Acco/Harrington or the distributor of the hoist with hoist product number and/or hoist serial number.

No Recommended Spare Parts

# PARTS LIST - PRODUCT SERIES 32

## TOP-RUNNING TROLLEY

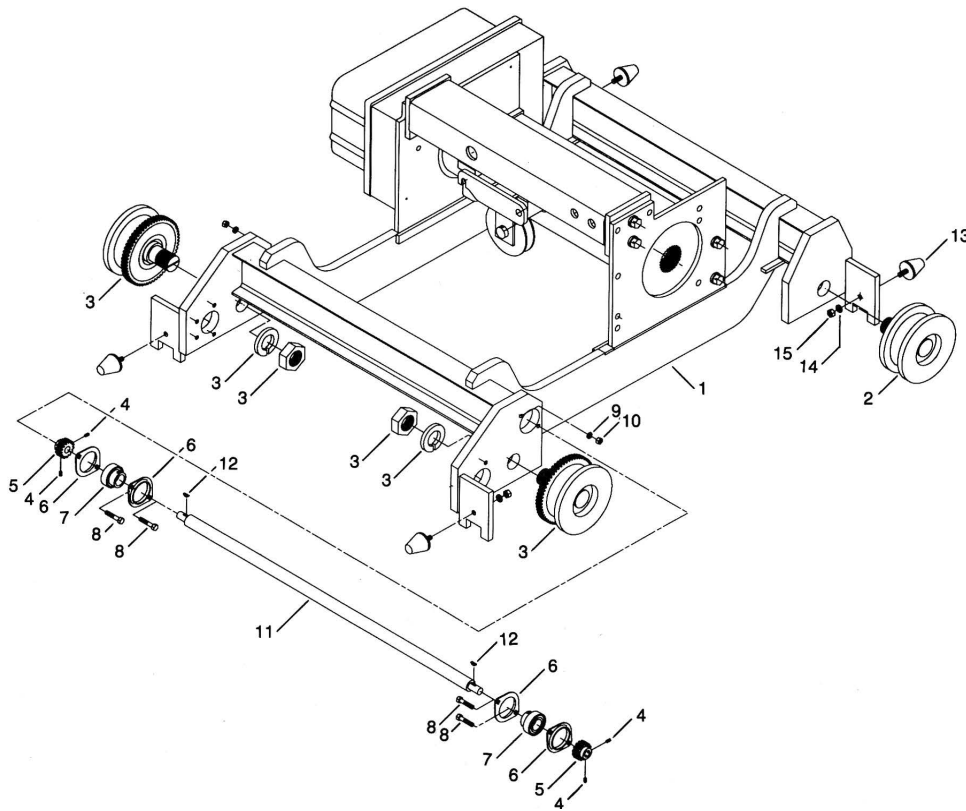

### TOP-RUNNING TROLLEY FRAME PARTS

ITEM NO.	DESCRIPTION	QUANTITY	PART NO.
1	Trolley Frame, Trolley End Beams, End Plates, Gear End and Control End	1	(a)
2	Plain Wheel Assembly	2	69421-02
3	Geared Wheel Assembly	2	69421-01
4	Set Screw	4	12-4-4C
5	Pinion	2	62214
6	Bearing Flange	4	PA6154
7	Bearing	2	PA6153
8	Hex Head Bolt	4	35-6-28
9	Lockwasher	4	17-6C
10	Nut	4	22-6
11	Shaft, Wheel Gage 60" (b)	1	69335
12	Woodruff Key	2	PA1357
13	Bumper (Optional)	4	65226
14	Lockwasher (Optional)	4	17-7
15	Nut (Optional)	4	22-7

### Notes:

For part numbers of other suspension frame parts, refer to page 10 for 2PS reeving or page 11 for 2PD reeving.

(a) Trolley side frame, trolley end beams, and hoist end plates are a single welded unit. Contact Acco/Harrington or the distributor of the hoist with hoist product number and/ or hoist serial number; and wheel gage of trolley.

(b) When dual motorized trolley drives are used, item numbers 4, 5, 6, 7, 8, 9, 10, 11 and 12 are not used. Trolleys with a wheel gage of 78" always use dual drives.

No Recommended Spare Parts

# PARTS LIST - PRODUCT SERIES 32

## LOADBAR ASSEMBLY OR FRAME ASSEMBLY FOR SWIVELING TROLLEYS – PARALLEL MOUNTED HOIST

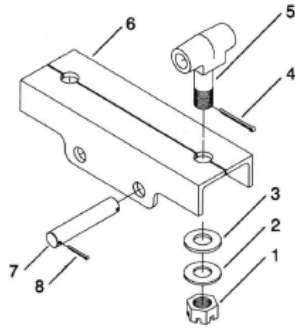

**FIGURE A - LOADBAR ASSEMBLY**  
2 PART SINGLE DRUM NOS. 1, 2

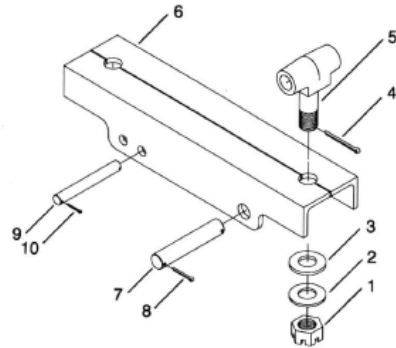

**FIGURE B - LOADBAR ASSEMBLY**  
2 PART SINGLE DRUM NOS. 3, 4, 5, 6

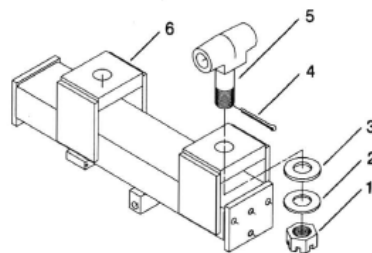

**FIGURE C - FRAME ASSEMBLY**  
2 PART DOUBLE DRUM NOS. 4, 5, 6, 7, 8

### LOADBAR PARTS

REFER TO FIGURE		A		B		C	
ITEM. NO.	DESCRIPTION	PART NUMBER	QTY	PART NUMBER	QTY	PART NUMBER	QTY
1	Hex Slotted Nut	26-28	2	26-28	2	26-28	2
2	Thrust Washer	A4421	2	A4421	2	A4421	2
3	Thrust Bearing	A4420	2	A4420	2	A4420	2
4	Cotter Pin	PA1484	2	PA1484	2	PA1484	2
5	Suspension Stud	63160	2	63160	2	63160	2
6	Loadbar or Frame Unit	69859 (b) 70717	1	69860-03 (a) 69860-04 69860-05 69860-06	1	69863-04 (a) 69863-05 69863-06 69863-07 69863-08	1
7	Pin	63208-02	2	63208-02	1	-	-
8	Cotter Pin	PA1932	4	PA1932	2	-	-
9	Pin	-	-	63299	2	-	-
10	Cotter Pin	-	-	PA1518	4	-	-

No Recommended Spare Parts

#### NOTES:

For trolley parts, refer to pages 25, 26, and 27.

(a) Dash number (-03, -04 etc.) indicates corresponding hoist drum length.

**Example:** 69860-03 for Drum No. 3, 69860-04 for Drum No. 4, etc.

(b) Part number 69859 is for Drum No. 1.

Part number 70717 is for Drum No. 2.

# PARTS LIST - PRODUCT SERIES 32

## FRAME ASSEMBLY - FOR SWIVELING TROLLEYS - CROSS MOUNTED HOIST

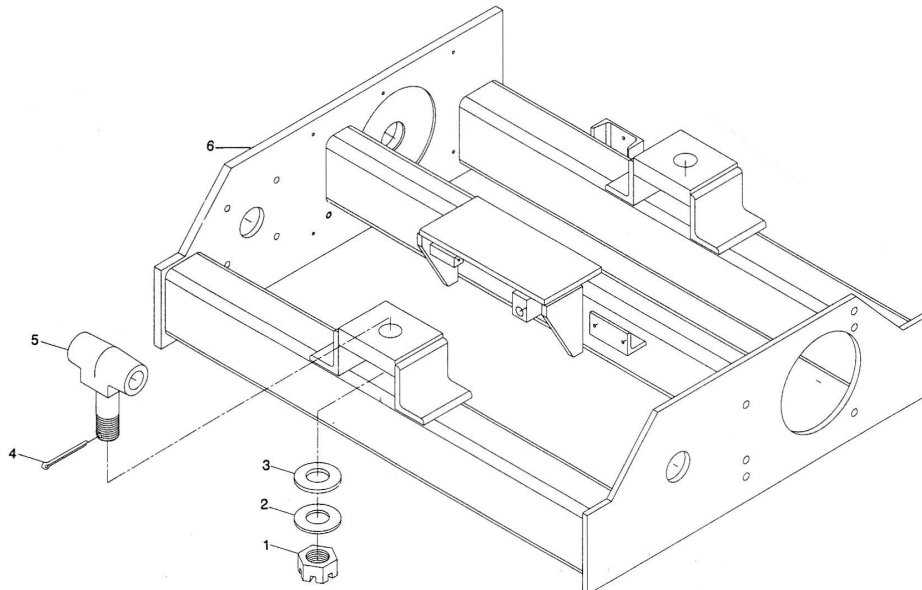

### 2 PART DOUBLE

#### FRAME PARTS

ITEM. NO.	DESCRIPTION	PART NUMBER	QTY.
1	Hex Slotted Nut	26-28	2
2	Thrust Washer	A4421	2
3	Thrust Bearing	A4420	2
4	Cotter Pin	PA1484	2
5	Suspension Stud	63160	2
6	Frame Unit (a)	70849-04	1
		70849-06	
		70849-07	

No Recommended Spare Parts

#### Notes:

For trolley parts, refer to pages 25, 26, and 27.

(a) Dash number (-04, -06, etc.) indicates corresponding hoist drum length.

**Example:** 70849-04 for Drum No. 4, 70849-06 for Drum No. 6, etc.

# PARTS LIST - PRODUCT SERIES 32

## FRAME ASSEMBLY - FOR LOUDEN TROLLEYS - CROSS MOUNTED HOIST

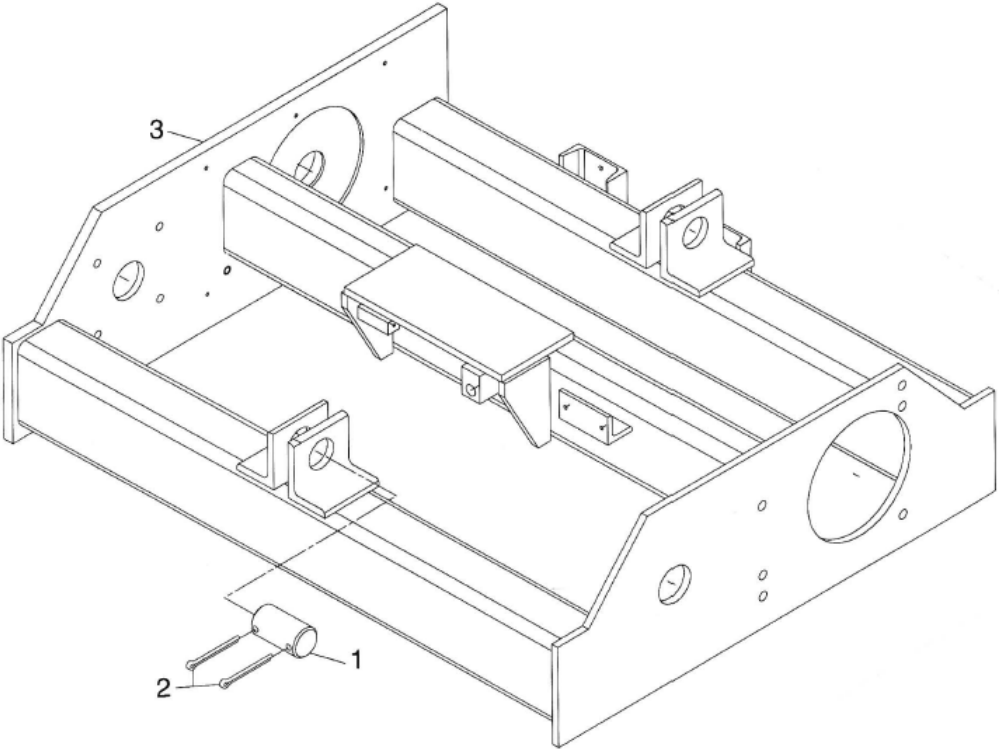

**2 PART DOUBLE**

**FRAME PARTS**

ITEM NO.	DESCRIPTION	QTY.	2 AND 3 TON HOIST CAPACITY PART NO.	5 TON HOIST CAPACITY PART NO.
1	Mounting Pin	2	70870	70871
2	Cotter Pin	4	PA3796	PA3796
3	Frame Unit (a)	1	70882-04	70883-04
			70882-06	70883-06
			70882-07	70883-07
Ref	Louden Trolley (b)	2	280070	280074

No Recommended Spare Parts

**Notes:**

- (a) Dash number (-04, -06, etc.) indicates corresponding hoist drum length.  
**Example:** 70882-04 for Drum No. 4, 70882-06 for Drum No. 6, etc.
- (b) Louden Trolley part numbers shown for reference only. For trolley parts, refer to page 101 of manual 69879.

# PARTS LIST - PRODUCT SERIES 32

## OPTIONAL ELECTRICAL CONTROL ENCLOSURE

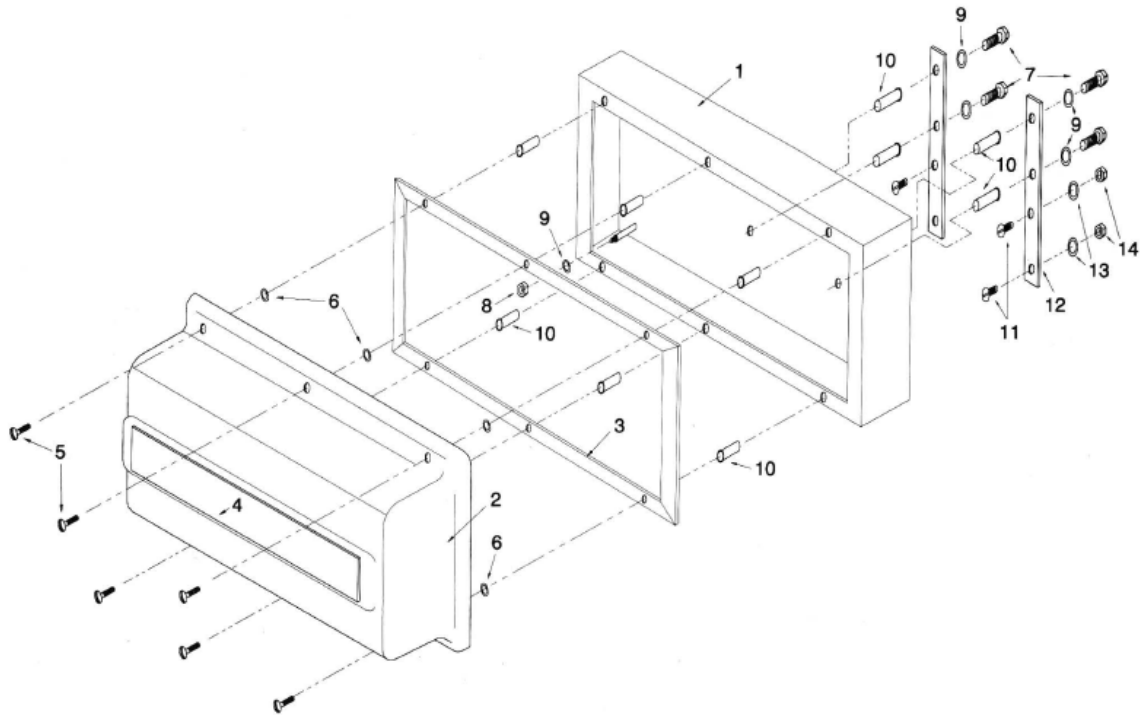

### REPLACEMENT PARTS

ITEM NO.	PART NO.	DESCRIPTION	QUANTITY BY ENCLOSURE SIZE		
			11" X 21"	15" X 21"	21" X 21"
1	69829-1	Enclosure, 11 x 21	1	N/A	N/A
	69828-1	Enclosure, 15 x 21	N/A	1	N/A
	69875-1	Enclosure, 21 x 21	N/A	N/A	1
2	52823	Cover, 11 x 21	1	N/A	N/A
	52826	Cover, 15 x 21	N/A	1	N/A
	54268	Cover, 21 x 21	N/A	N/A	1
3	58531	Gasket, 11 x 21	1	N/A	N/A
	55204	Gasket, 15 x 21	N/A	1	N/A
	55206	Gasket, 21 x 21	N/A	N/A	1
4	55224-2	Label	1	1	1
5	58597	Screw, Captive	6	6	8
6	PA6634	Ring, Retaining	6	6	8
7	35-4-12	Hex Head Bolt	4	4	4
8	22-4C	Hex Nut	4	4	4
9	17-4C	Lockwasher	8	8	8
10	PA7343	Nut Insert, Closed End	10	10	12
11	5-6-20	Flathead Screw (a)	4	4	4
12	69808	Enclosure Mounting Strap (a)	2	2	2
13	17-6C	Lockwasher (a)	4	4	4
14	22-6	Hex Nut (a)	4	4	4

### NOTE:

(a) Item number 11, 12, 13 and 14 are not used on cross mounted hoists.

**THIS PAGE INTENTIONALLY  
LEFT BLANK**

**THIS PAGE INTENTIONALLY  
LEFT BLANK**

## **GENERAL CONDITIONS OF WARRANTY**

Buyer must notify HHI in writing within sixty (60) days of discovery of any alleged defect, if within the applicable warranty period.

All products sold by HHI are warranted to be free from defects in material and workmanship from date of shipment by HHI for the following periods:

- 1 year – Air Powered Hoists, SNER, TNER, NER030L, and ED Electric Chain Hoists, Powered Trolleys, Powered Tiger Track Jibs and Gantries, Crane Components, Below the Hook Devices, Spare / Replacement Parts**
- 2 years – Manual Hoists & Trolleys, Beam Clamps, ACCO Wire Rope Hoists, ACCOLIFT Electric Chain Hoists, Louden and Trambeam Patented Track**
- 3 years – (N)ER2 Hoists, EQ/SEQ Hoists, (T)EM/(T)SEM hoists, and RY Hoists**
- 5 years – Manual Tiger Track Jibs and Gantries, Hoist Motor Brakes for EQ/SEQ, (T)EM/(T)SEM, and RY**
- 10 years – (N)ER2 Brake, TNER Hoist Motor Brake, Tiger Track Workstation Cranes and Monorails**

The product must be used in accordance with manufacturer's recommendations and must not have been subject to abuse, lack of maintenance, misuse, negligence, or unauthorized repairs or alterations.

Should any defect in material or workmanship occur during the above time period in any product, as determined by HHI's inspection of the product, HHI agrees, at its discretion, either to replace (not including installation) or repair the part or product free of charge. For customers in the U.S., delivery shall be made F.O.B. HHI's place of business. For international customers, delivery shall be made FCA HHI place of business, United States of America (Incoterms 2010).

No warranty claim will be honored without a valid proof of purchase. Customers must obtain a Return Goods Authorization as directed by HHI or its published repair center prior to shipping product for warranty evaluation. An explanation of the complaint must accompany the product. Product must be returned freight prepaid. Upon repair, the product will be covered for the remainder of the original warranty period. Replacement parts installed after the original warranty period will only be eligible for replacement (not including installation) for a period of one year from the installation date. If it is determined there is no defect, or that the defect resulted from causes not within the scope of HHI's warranty, the customer will be responsible for the costs of returning the product.

HHI DISCLAIMS ANY AND ALL OTHER WARRANTIES OF ANY KIND, EXPRESSED OR IMPLIED, AS TO THE PRODUCT'S MERCHANTABILITY OR FITNESS FOR A PARTICULAR PURPOSE. HHI WILL NOT BE LIABLE FOR DEATH, INJURIES TO PERSONS OR PROPERTY OR FOR INCIDENTAL, CONTINGENT, SPECIAL OR CONSEQUENTIAL DAMAGES, LOSS OR EXPENSE ARISING IN CONNECTION WITH THE USE OR MISUSE OF THE PRODUCTS, REGARDLESS OF WHETHER THE DAMAGE, LOSS OR EXPENSE RESULTS FROM ANY ACT OR FAILURE TO ACT BY HHI, WHETHER NEGLIGENT OR WILLFUL, OR FROM ANY OTHER CAUSE.



Harrington Hoists, Inc.  
401 West End Avenue  
Manheim, PA 17545

[www.harringtonhoists.com](http://www.harringtonhoists.com)

Toll Free: 800-233-3010  
Phone: 717-665-2000  
Fax: 717-665-2861

© HARRINGTON HOISTS, INC.  
ALL RIGHTS RESERVED

ACC69834-20