



WORK-RATED®

THE NEW CENTURY SERIES®

Wire Rope Electric Hoists

Product Series 35

Parts Manual

SERIAL NUMBER

WARNING

This equipment should not be installed, operated or maintained by any person who has not read all the contents of Instruction, Operation, and Maintenance Manual 69833; and Parts Manual 69837. Failure to read and comply with the instructions or any one of the limitations noted in either manual can result in serious bodily injury or death, and/or property damage.

There are no other warranties which extend beyond the description on the Order Acknowledgment and as it may apply to the specifications provided in this publication. THE IMPLIED WARRANTIES OF MERCHANTABILITY AND FITNESS FOR A PARTICULAR PURPOSE ARE EXCLUDED. Acco Material Handling Solutions/Harrington Hoists, Inc., shall in no event be liable for any special, direct, indirect, incidental or consequential damages to anyone beyond the cost of replacement of the goods sold hereby.



TABLE OF CONTENTS

NOTICE

Parts Manual 69837 covers parts information in reference to Product Series 35 of the WRIGHT® WORK-RATED® THE NEW CENTURY SERIES® wire rope electric hoist line. This manual includes parts information for a variety of hoist types. Therefore, all parts information may not apply to any one type or size of specific hoist. Disregard those portions of the manual that do not apply. Parts Manual 69837 should be used in conjunction with Manual 69833: Installation, Operation, and Maintenance Manual for WRIGHT® WORK-RATED® THE NEW CENTURY SERIES® Wire Rope Electric Hoists. Refer to Manual 69833 for instructions on installation, operation, inspection, testing, adjusting, and maintaining this equipment; and Parts Manual 69837 for parts information and identification. Use of the term MANUAL refers to both Manual 69833 and Parts Manual 69837.

<u>SUBJECT</u>	<u>PAGE</u>
IMPORTANT INFORMATION AND WARNINGS.....	3
HOIST MOTOR BRAKE ASSEMBLY.....	5
HOIST GEAR HOUSING ASSEMBLY.....	6
HOIST MOTOR.....	8
SUSPENSION - 2PS REEVING.....	9
SUSPENSION - 4PS REEVING.....	10
SUSPENSION - 2PD REEVING.....	11
SUSPENSION - 4PD REEVING.....	12
LOAD BLOCK - 2PS REEVING.....	13
LOAD BLOCK - 4PS REEVING.....	14
LOAD BLOCK - 2PD REEVING.....	15
LOAD BLOCK - 4PD REEVING.....	16
GRAVITY LIMIT SWITCH.....	17
GEARED LIMIT SWITCH.....	18
HOIST RECTIFIED D.C. BRAKE CONTROL.....	19
BASIC CONTROL COMPONENTS.....	20
PENDANT CONTROL STATION.....	23
2-WHEEL PLAIN TROLLEY - 6 IN. DIA. WHEEL.....	25
4-WHEEL PLAIN TROLLEY - 6 IN. DIA. WHEEL.....	26
4-WHEEL GEARED TROLLEY - 6 IN. DIA. WHEEL.....	27
4-WHEEL GEARED TROLLEY - DUAL DRIVE - 6 IN. DIA. WHEEL.....	28
LOAD BAR ASSEMBLY FOR RIGID TROLLEYS.....	29
HAND-GEARED TROLLEY DRIVE.....	30
MOTORIZED MONORAIL TROLLEY DRIVE.....	31
MOTORIZED MONORAIL TROLLEY RIGHT-ANGLE REDUCER.....	32
MOTORIZED TOP-RUNNING TROLLEY DRIVE ASSEMBLY.....	33
TROLLEY MOTOR BRAKE ASSEMBLY.....	34
DECK MOUNTED FRAME.....	35
WINCH UNIT FRAME.....	35
TOP-RUNNING TROLLEY.....	36
LOAD BAR ASSEMBLY FOR SWIVELING TROLLEYS.....	37
OPTIONAL ELECTRICAL CONTROL ENCLOSURE.....	38

NOTICE

TO ORDER PARTS: Provide part number, part description, quantity required, and Product Number or Serial Number of Hoist.

IMPORTANT INFORMATION AND WARNINGS

SAFETY ALERT SYMBOL

The Safety Alert Symbol is used in this manual to indicate hazards and to alert the reader to information that should be known, understood, and followed in order to avoid DEATH or SERIOUS INJURY.

Read and understand this manual before using the hoist.

Important issues to remember during operation are provided at the hoist control stations, at various locations on the hoist and in the manuals by **DANGER, WARNING, or CAUTION** instructions or placards, that alert the personnel to potential hazards, proper operation, load limitations, and more.

DANGER

Indicates an imminently hazardous situation which, if not avoided, will result in death or serious injury.

WARNING

Indicates a potentially hazardous situation which, if not avoided, could result in death or serious injury.

CAUTION

Indicates a potentially hazardous situation which, if not avoided, may result in minor or moderate injury. It may also be used to alert against unsafe practices.

CAUTION

These general instructions deal with the normal installation, operation, and maintenance situations encountered with the equipment described herein. The instructions should not be interpreted to anticipate every possible contingency or to anticipate the final system, crane, or configuration that uses this equipment.

This manual includes instructions and parts information for a variety of hoist types. Therefore, all instructions and parts information may not apply to any one type or size of specific hoist. Disregard those portions of the instructions that do not apply.

Record hoist serial number on the front cover of this manual for identification and future reference to avoid referring to the wrong manual for information or instructions on installation, operation, inspection, maintenance, or parts.

Use only Wright® authorized replacement parts in the service and maintenance of this hoist.

WARNING

Equipment described herein is not designed for and should not be used for lifting, supporting, or transporting humans.

Equipment described herein should not be used in conjunction with other equipment unless necessary and/or required safety devices applicable to the system, crane, or application are installed by the system designer, system manufacturer, crane manufacturer, installer, or user.

Modifications to upgrade, rerate, or otherwise alter this equipment shall be authorized only by the original equipment manufacturer or qualified professional engineer.

Equipment described herein may be used in the design and manufacture of cranes or monorails. Additional equipment or devices may be required for the crane or monorail to comply with applicable crane design and safety standards. The crane designer, crane manufacturer, or user is responsible to furnish these additional items for compliance. Refer to ASME B30.17, Safety Standard for Top-Running Single Girder Cranes; ASME B30.2 Safety Standard for Top-Running Double-Girder Cranes; and ASME B30.11 Safety Standard for Underhung Cranes and Monorails. If a below-the-hook lifting device or sling is used with a hoist, refer to ASME B30.9, Safety Standard for Slings, or ASME B30.20, Safety Standard for Below-the-Hook Lifting Devices.

Hoists and cranes, used to handle hot molten material may require additional equipment or devices. Refer to ANSI Z241.2, Safety Requirements for Melting and Pouring of Metals in the Metalcasting Industry.

Electrical equipment described herein is designed and built in compliance with ACCO/Harrington's interpretation of ANSI/NFPA 70, National Electrical Code. The system designer, system manufacturer, crane designer, crane manufacturer, installer, or user is responsible to assure that the installation and associated wiring of these electrical components is in compliance with ANSI/NFPA 70, and all applicable Federal, State, and Local Codes.

Failure to read and comply with any of the limitations noted herein can result in serious bodily injury or death, and/or property damage.

IMPORTANT INFORMATION AND WARNINGS

⚠ DANGER

HAZARDOUS VOLTAGES ARE PRESENT IN THE CONTROL ENCLOSURE, OTHER ELECTRICAL COMPONENTS, AND CONNECTIONS BETWEEN THESE COMPONENTS.

Before performing ANY mechanical or electrical maintenance on the equipment, de-energize (disconnect) the main switch supplying power to the equipment; and lock and tag the main switch in the de-energized position. Refer to ANSI Z244.1, Personnel Protection - Lockout/Tagout of Energy Sources.

Do not operate the equipment without control enclosure cover or covers in place.

Only trained and competent personnel should inspect and repair this equipment.

NOTICE

It is the responsibility of the owner/user to install, inspect, test, maintain, and operate a hoist in accordance with ASME B30.16, Safety Standard for Overhead Hoists, OSHA Regulations, and ANSI/NFPA 70, National Electrical Code. If the hoist is installed as part of a total lifting system, such as an overhead crane or monorail, it is also the responsibility of the owner/user to comply with the applicable ASME B30 volume that addresses that type of equipment.

It is the responsibility of the owner/user to have all personnel that will install, inspect, test, maintain, and operate a hoist read the contents of this manual and applicable portions of ASME B30.16, Safety Standard for Overhead Hoists, OSHA Regulations, and ANSI/NFPA 70, National Electrical Code. If the hoist is installed as part of a total lifting system, such as an overhead crane, the applicable ASME B30 volume that addresses that type of equipment must also be read by all personnel.

Any ANSI Standards referenced in this manual may be obtained from the American National Standards Institute, 1430 Broadway, New York, New York 10018.

This manual contains information for safe operation of an overhead hoist. Taking precedence over any specific rule, however, is the most important rule of all "USE COMMON SENSE." Operation of an overhead hoist involves more than operating the controls. The operator must consider and anticipate the motions and actions that will occur as a result of operating the controls.

If the hoist owner/user requires additional information, or if any information in the manual is not clear, contact ACCO/Harrington or the distributor of the hoist. Do not install, inspect, test, maintain, or operate the hoist unless this information is fully understood.

When contacting ACCO/Harrington or the distributor of the hoist, always make reference to the serial number of the hoist.

A regular schedule of inspection of the hoist in accordance with the requirements of the ASME B30.16 should be established and records maintained.

⚠ WARNING

Before installing, removing, inspecting, or performing any maintenance on a hoist, the main switch shall be de-energized. Lock and tag the main switch in the de-energized position in accordance with ANSI Z244.1. Follow other maintenance procedures outlined in this manual and applicable ASME B30 volumes.

Additional WARNINGS are listed in various portions of this manual. Personnel shall read and follow these WARNINGS. Failure to read and comply with these WARNINGS as well as other instructions or any limitations noted in this manual and applicable ASME B30 volumes could result in serious bodily injury or death, and/or property damage.

PARTS LIST - PRODUCT SERIES 35

HOIST MOTOR BRAKE ASSEMBLY

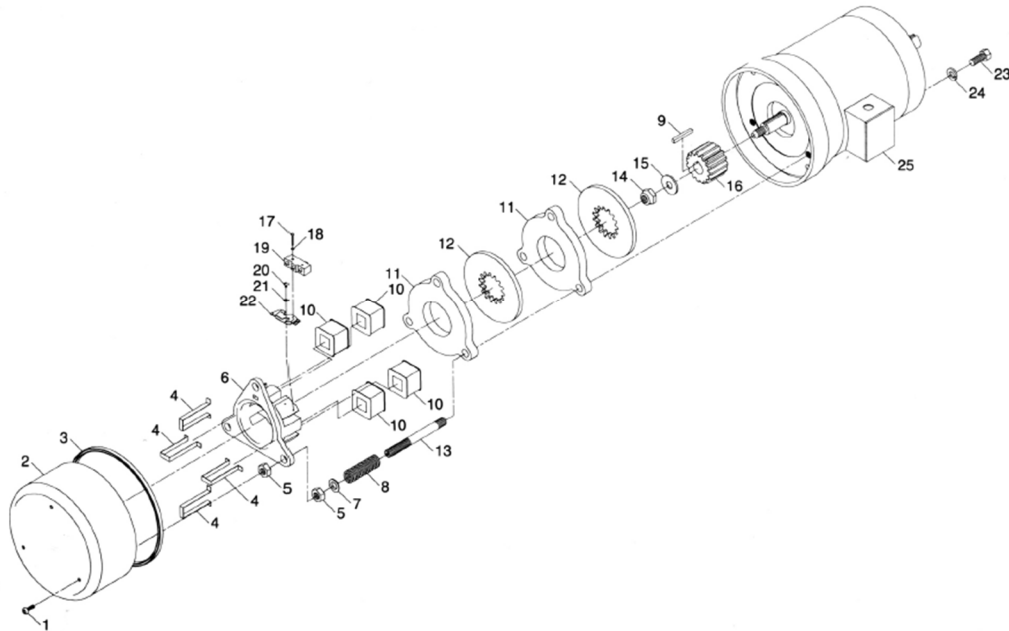

HOIST MOTOR BRAKE PARTS

ITEM NO.	DESCRIPTION	QTY	68 LB FT TORQUE (a)	90 LB FT TORQUE (a)
			69757-21 (b) (c)	69757-31 (b) (c)
			PART NO.	PART NO.
1*	Screw, LOC-WELL (d)	3	PA7323	PA7323
2	Cover	1	69743-03	69743-03
3*	Gasket	3.1 ft	PA7110	PA7110
4	Coil Strap	4	51451	51451
5	Nut, Jam	6	24-12C	24-12C
6	Magnet	1	51447	51447
7	Washer	3	PA5183	PA5183
8	Spring	3	PA6275 (e)	PA6078 (e)
9	Key	1	(g)	(g)
10	Coil	4	51452	51452
11	Armature Plate	2	51443	51443
12*	Lining Disc	2	51439	51439
13	Stud	3	69991	69991
14*	Locknut	1	PA2434	PA2434
15	Washer	1	15-10-0	15-10-0
16	Hub	1	69990	69990
17	Screw	2	3-06-14	3-06-14
18	Lockwasher	2	19-06	19-06
19	Switch	1	PA6079	PA6079
20	Screw	2	3-08-4	3-08-4
21	Lockwasher	2	19-08C	19-08C
22	Mounting Bracket	1	PA6080	PA6080
23	Bolt	4	(f)	(f)
24	Lockwasher	4	(f)	(f)
25	Motor	1	(f)	(f)

*Recommended Spare Parts

NOTES:

- (a) On standard hoists, 68 lb. ft. torque brakes are used with single-speed and two-speed 15 HP motors; and 90 lb. ft. torque brakes are used with single-speed and two-speed 20 HP motors.
- (b) Numbers in heading of chart are Hoist Motor Brake Assembly numbers.
- (c) This brake is not used on hoists in Hazardous (Classified) locations as identified by the National Electrical Code.
- (d) Screw with self-locking feature must be utilized. Substitutes are not permissible.
- (e) Springs are color coded. Spring (PA6275) for 68 lb. ft. torque brake is yellow color. Spring (PA6078) for 90 lb. ft. torque brake is red color.
- (f) For part numbers, refer to page 8, Hoist Motor.
- (g) Included with hoist motor.

HOIST GEAR HOUSING ASSEMBLY

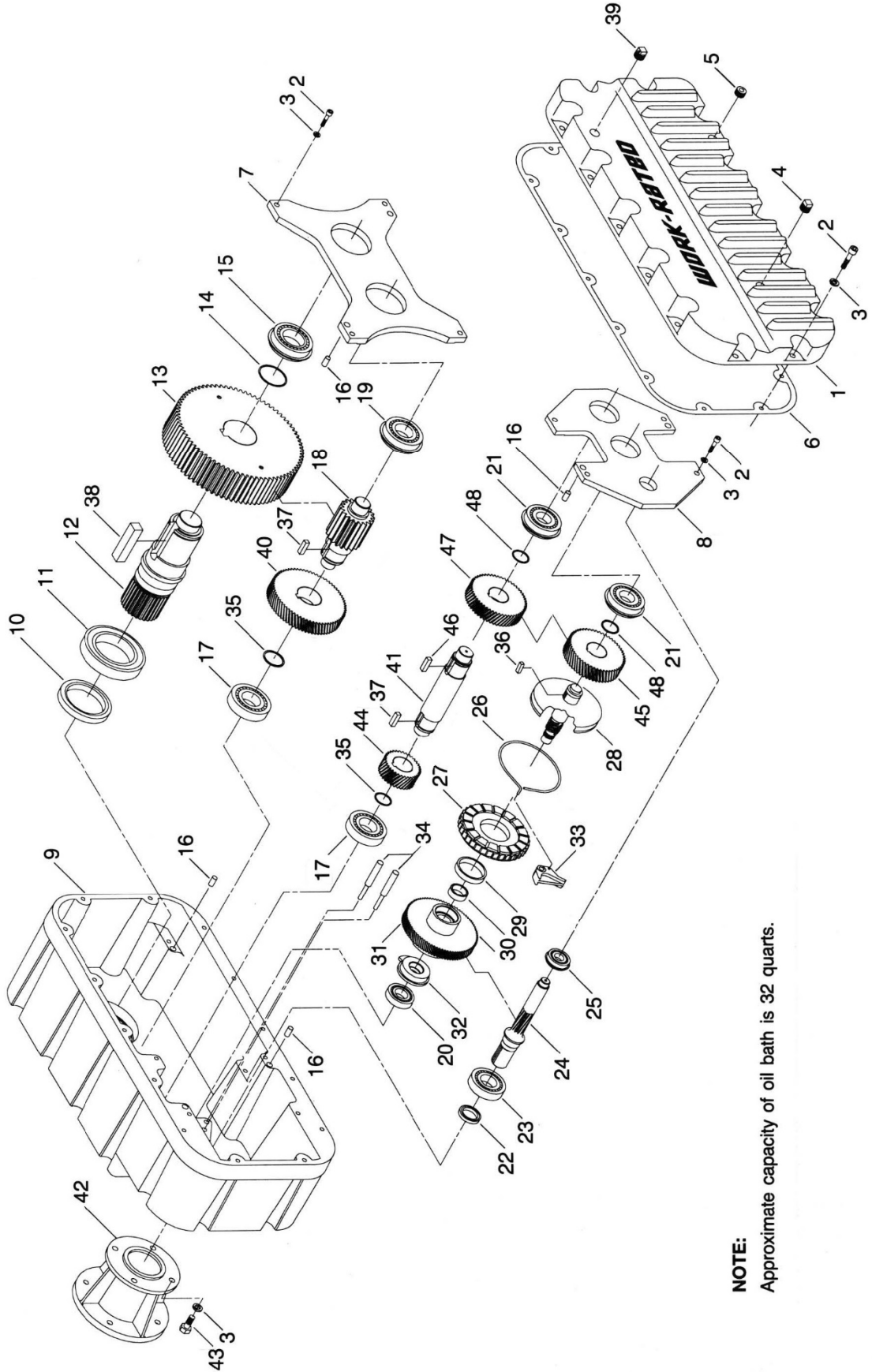

NOTE:
Approximate capacity of oil bath is 32 quarts.

PARTS LIST - PRODUCT SERIES 35

HOIST GEAR HOUSING ASSEMBLY

HOIST GEAR HOUSING PARTS

ITEM NO.	PART NUMBER	DESCRIPTION	QTY/ ASSY
1	70079	Gear Housing Cover	1
2	1-8-24	Bolt, 1/2-13 x 1-1/2	24
3	17-8C	Lockwasher, 1/2	28
4	PA7380	Oil Level Plug	1
5	PA798	Pipe Plug	1
6*	70080	Gasket	1
7	70082	Output Spider	1
8	70081	Input Spider	1
9	70078	Gear Housing	1
10*	PA7441	Oil Seal	1
11	PA7439	Bearing	1
12	70085	Drum Shaft	1
13	70086	Drum Gear	1
14	PA7489	Retaining Ring	1
15	PA7492	Bearing	1
16	PA7493	Dowel Pin	4
17	PA7490	Bearing	2
18	70295	Drum Pinion Shaft	1
19	PA7491	Bearing	1
20	PA1992	Bearing	1
21	PA5770	Bearing	2
22*	PA7442	Oil Seal	1
23	PA7434	Bearing	1
24	70083	Motor Pinion Shaft	1

ITEM NO.	PART NUMBER	DESCRIPTION	QTY/ ASSY
25	PA4847	Bearing	1
26	55974	Pawl Spring	1
27	58036	Ratchet Unit	1
28	60023	Brake Shaft Unit	1
29	PA6620	Needle Bearing, Outer	1
30	PA6749	Needle Bearing, Inner	1
31	60021	Brake Gear	1
32	58033	Check Sleeve	1
33	60799	Pawl	1
34	70299	Pawl Pin	2
35	PA7488	Retaining Ring	2
36	70056	Key	1
37	70302	Key	2
38	70303	Key	1
39	PA7381	Vent Plug	1
40	(a)	Change Gear	(a)
41	70084	Change Shaft	1
42	(a)	Motor Snout	(a)
43	35-8-20C	Bolt, 1/2-13 x 1-1/4	4
44	(a)	Change Pinion	(a)
45	70087	Pinion	1
46	70301	Key	1
47	70088	Gear	1
48	PA6625	Retaining Ring	2

NOTE:

- (a) Gearing varies with the speed of the hoist. Two gear sets are available, each identified by Gear Housing Assembly No. 70300 with dash number suffix (-01 through -04). Select proper dash number by counting and comparing number of teeth in gear and pinion. The parts of this assembly that affect the speed of the hoist are items 40 and 44. Also, Gear Housing Assembly No. 70300 will accept either motor frame sizes 256TC or 286TC. Assembly number for motor frame size is determined by motor snout, item 42. Refer to dash number suffix (-01 through -04) below.

GEAR HOUSING ASSEMBLY			70300-01	70300-02	70300-03	70300-04
LIFTING SPEED (2PS/2PD)			30 FPM	44 FPM	30 FPM	44FPM
LIFTING SPEED (4PS/4PD)			15 FPM	22 FPM	15 FPM	22 FPM
MOTOR FRAME SIZE			256TC	256TC	286TC	286TC
ITEM NO.	PART NO.	DESCRIPTION	QTY.	QTY.	QTY.	QTY.
40	70091	Gear, 68 Teeth	0	1	0	1
40	70092	Gear, 77 Teeth	1	0	1	0
42	70038	Motor Snout, 256	1	1	0	0
42	70297	Motor Snout, 286	0	0	1	1
44	70089	Pinion, 31 Teeth	1	0	1	0
44	70090	Pinion, 40 Teeth	0	1	0	1

*Recommended Spare Parts

PARTS LIST - PRODUCT SERIES 35

HOIST MOTOR

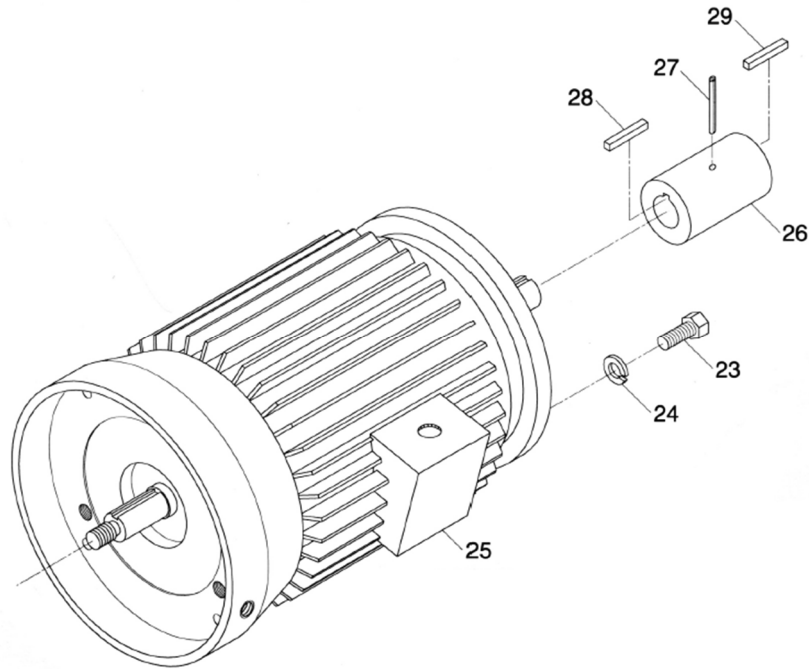

HOIST MOTOR PARTS

ITEM NO.	PART NO.	DESCRIPTION	QTY
23	35-8-20C	Bolt, Hex Head	4
24	17-8C	Lockwasher	4
25	(b)	Hoist Motor	1
26	70055 70298	Coupling, 256TC Coupling, 286TC	1
27	PA5366 PA5341	Roll Pin, 256TC Roll Pin, 286TC	1
28	(a)	Key	1
29	70054	Key	1

No Recommended Spare Parts

NOTES:

- (a) Included with hoist motor.
- (b) Select standard hoist motor by part number according to motor specifications as follows:

Motor part number 69777-13: 15 HP single speed, 1800 rpm, 208 volt, frame 256TC.
 Motor part number 69777-14: 15 HP single speed, 1800 rpm, 230/460 volt, frame 256TC.
 Motor part number 69777-15: 15 HP single speed, 1800 rpm, 575 volt, frame 256TC.
 Motor part number 69777-16: 20 HP single speed, 1800 rpm, 208 volt, frame 256TC.
 Motor part number 69777-17: 20 HP single speed, 1800 rpm, 230/460 volt, frame 256TC.
 Motor part number 69777-18: 20 HP single speed, 1800 rpm, 575 volt, frame 256TC.
 Motor part number 69778-17: 15/5 HP two speed, 1800/600 rpm, 208 volt, frame 256TC.
 Motor part number 69778-18: 15/5 HP two speed, 1800/600 rpm, 230 volt, frame 256TC.
 Motor part number 69778-19: 15/5 HP two speed, 1800/600 rpm, 460 volt, frame 256TC.
 Motor part number 69778-20: 15/5 HP two speed, 1800/600 rpm, 575 volt, frame 256TC.
 Motor part number 69778-21: 20/6.67 HP two speed, 1800/600 rpm, 208 volt, frame 286TC.
 Motor part number 69778-22: 20/6.67 HP two speed, 1800/600 rpm, 230 volt, frame 286TC.
 Motor part number 69778-23: 20/6.67 HP two speed, 1800/600 rpm, 460 volt, frame 286TC.
 Motor part number 69778-24: 20/6.67 HP two speed, 1800/600 rpm, 575 volt, frame 286TC.

For other specified special motors, refer to additional information pages supplied with manual.

PARTS LIST - PRODUCT SERIES 35

SUSPENSION - 2PS REEVING

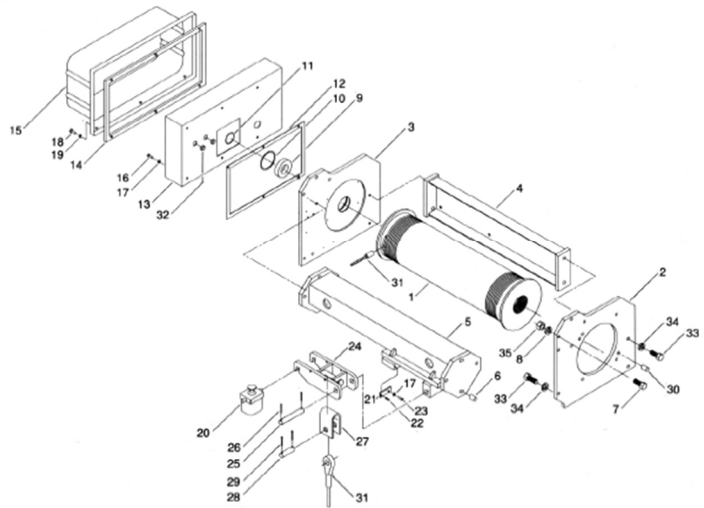

2PS SUSPENSION PARTS

ITEM NO.	DESCRIPTION	QTY.	20 FT. LIFT PART NO.	51 FT. LIFT PART NO.	70 FT. LIFT PART NO.	95 FT. LIFT PART NO.
1	Drum, Single Grooving	1	70312-01	70312-02	70312-03	70312-04
2	End Plate, Gear End	1	70310	70310	70310	70310
3	End Plate, Control End	1	70311	70311	70311	70311
4	Side Frame	1	70172-01	70172-02	70172-03	70172-04
5	Frame Unit	1	70382-01	70382-02	70391-03	70391-04
6	Dowel Pin	4	PA7497	PA7497	PA7497	PA7497
7	Hex Head Bolt	4	35-12-52	35-12-52	35-12-52	35-12-52
8	Lockwasher	4	17-12C	17-12C	17-12C	17-12C
9	Bearing	1	PA7451	PA7451	PA7451	PA7451
10	Retaining Ring	1	PA7456	PA7456	PA7456	PA7456
11	Retaining Ring	1	PA7455	PA7455	PA7455	PA7455
12	Gasket	1	70139	70139	70139	70139
13	Enclosure	1	70138-01	70138-01	70138-01	70138-01
14	Gasket	1	58531	58531	58531	58531
15	Cover	1	52823	52823	52823	52823
16	Hex Head Bolt	6	35-4-6C	35-4-6C	35-4-6C	35-4-6C
17	Lockwasher	7	17-4C	17-4C	17-4C	17-4C
18	Captive Screw	6	58597	58597	58597	58597
19	Retaining Ring	6	PA6634	PA6634	PA6634	PA6634
20	Overload Cut-off 7½ Ton	1	39173-04	39173-04	39173-04	39173-04
20	Overload Cut-off 10 Ton	1	39174-04	39174-04	39174-04	39174-04
21	Keeper Plate	1	53219	53219	53219	53219
22	Roll Pin	1	PA4607	PA4607	PA4607	PA4607
23	Hex Head Bolt	1	35-4-8C	35-4-8C	35-4-8C	35-4-8C
24	Rope End Mounting Unit	1	70338	70338	70338	70338
25	Pin	1	69717-01	69717-01	69717-01	69717-01
26	Cotter Pin	2	PA1364	PA1364	PA1364	PA1364
27	Rope Hanger	1	70339	70339	70339	70339
28	Pin	1	70340	70340	70340	70340
29	Cotter Pin	2	PA1355	PA1355	PA1355	PA1355
30	Dowel Pin	2	PA7487	PA7487	PA7487	PA7487
31*	Wire Rope Assembly (a)	1	70337-01	70337-02	70337-03	70337-04
32	Grommet	2	PA7409	PA7409	PA7409	P7409
33	Hex Head Bolt	10	35-10-32	35-10-32	35-10-32	35-10-32
34	Lockwasher	10	17-10C	17-10C	17-10C	17-10C
35	Hex Nut	4	22-12C	22-12C	22-12C	22-12C

*Recommended Spare Parts

NOTE: (a) Part numbers shown for Item 31, Wire Rope Assembly, are for standard hoists using 3/4 dia. 6x37 XIP wire rope. For special hoists using other size or type wire rope, refer to the wire rope part number listed in additional pages included with this manual; or contact Acco/Harrington or the distributor of the hoist.

PARTS LIST - PRODUCT SERIES 35

SUSPENSION - 4PS REEVING

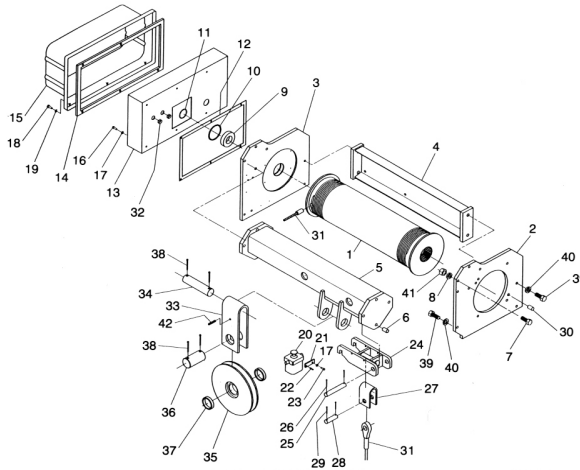

4PS SUSPENSION PARTS

ITEM NO.	DESCRIPTION	QTY.	21 FT. LIFT PART NO.	34 FT. LIFT PART NO.	53 FT. LIFT PART NO.	79 FT. LIFT PART NO.
1	Drum Single Grooving	1	70312-03	70312-04	70312-05	70312-06
2	End Plate Gear End	1	70310	70310	70310	70310
3	End Plate Control End	1	70311	70311	70311	70311
4	Side Frame	1	70172-03	70172-04	70172-15	70172-16
5	Frame Unit	1	(b)	(b)	70401-05	70401-06
6	Dowel Pin •	4	PA7497	PA7497	PA7497	PA7497
7	Hex Head Bolt	4	35-12-52	35-12-52	35-12-52	35-12-52
8	Lockwasher	4	17-12C	17-12C	17-12C	17-12C
9	Bearing	1	PA7451	PA7451	PA7451	PA7451
10	Retaining Ring	1	PA7456	PA7456	PA7456	PA7456
11	Retaining Ring	1	PA7455	PA7455	PA7455	PA7455
12	Gasket	1	70139	70139	70139	70139
13	Enclosure	1	70138-01	70138-01	70138-01	70138-01
14	Gasket	1	58531	58531	58531	58531
15	Cover	1	52823	52823	52823	52823
16	Hex Head Bolt	6	35-4-6C	35-4-6C	35-4-6C	35-4-6C
17	Lockwasher	7	17-4C	17-4C	17-4C	17-4C
18	Captive Screw	6	58597	58597	58597	58597
19	Retaining Ring	6	PA6634	PA6634	PA6634	PA6634
20	Overload Cut-off 15 Ton	1	39173-04	39173-04	39173-04	39173-04
20	Overload Cut-off 20 Ton	1	39174-04	39174-04	39174-04	39174-04
21	Keeper Plate	1	53219	53219	53219	53219
22	Roll Pin	1	PA4607	PA4607	PA4607	PA4607
23	Hex Head Bolt	1	35-4-8C	35-4-8C	35-4-8C	35-4-8C
24	Rope End Mounting Unit	1	70338	70338	70338	70338
25	Pin	1	69717-01	69717-01	69717-01	69717-01
26	Cotter Pin	2	PA1364	PA1364	PA1364	PA1364
27	Rope Hanger	1	70339	70339	70339	70339
28	Pin	1	70340	70340	70340	70340
29	Cotter Pin	2	PA1355	PA1355	PA1355	PA1355
30	Dowel Pin	2	PA7487	PA7487	PA7487	PA7487
31*	Wire Rope Assembly (a)	1	70337-13	70337-14	70337-15	70337-16
32	Grommet	2	PA7409	PA7409	PA7409	PA7409
33	Sheave Hanger	1	70341	70341	70341	70341
34	Pin	1	70342	70342	70342	70342
35	Polyamide Sheave with Bearing	1	69579	69579	69579	69579
35	Steel Sheave with Bearing	1	69580	69580	69580	69580
36	Pin	1	70343	70343	70343	70343
37	Spacer	2	69581-02	69581-02	69581-02	69581-02
38	Cotter Pin	4	PA3796	PA3796	PA3796	PA3796
39	Hex Head Bolt	10	35-10-32	35-10-32	35-10-32	35-10-32
40	Lockwasher	10	17-10C	17-10C	17-10C	17-10C
41	Hex Nut	4	22-12C	22-12C	22-12C	22-12C
42	Pin	1	PA3713	PA3713	PA3713	PA3713

*Recommended Spare Parts

NOTES: (a) Part numbers shown for Item 31, Wire Rope Assembly, are for standard hoists using 3/4 dia. 6x37 XIP wire rope. For special hoists using other size or type wire rope, refer to the wire rope part number listed in additional pages included with this manual; or contact Acco/Harrington or the distributor of the hoist.

(b) For 15 ton capacity, 21 ft. lift frame is 70319-03, 34 ft. lift frame is 70319-04.
For 20 ton capacity, 21 ft. lift frame is 70467, 34 ft. lift frame is 70401-04.

PARTS LIST - PRODUCT SERIES 35

SUSPENSION – 2PD REEVING

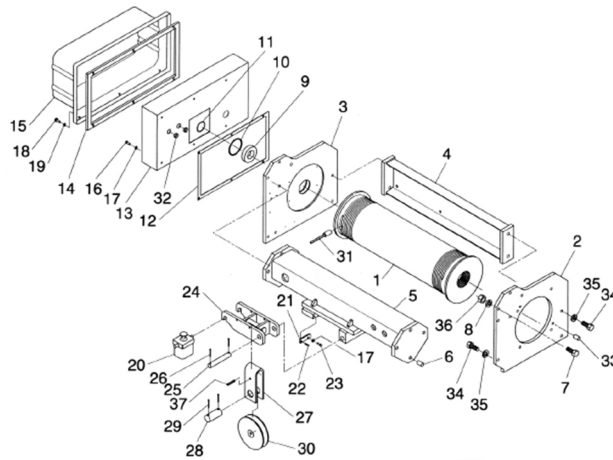

2PD SUSPENSION PARTS

ITEM NO.	DESCRIPTION	QTY.	24 FT. LIFT PART NO.	38 FT. LIFT PART NO.	57 FT. LIFT PART NO.	85 FT. LIFT PART NO.
1	Drum, Double Grooving	1	70313-02	70313-03	70313-04	70313-05
2	End Plate, Gear End	1	70310	70310	70310	70310
3	End Plate, Control End	1	70311	70311	70311	70311
4	Side Frame	1	70172-02	70172-03	70172-04	70172-15
5	Frame Unit	1	70397	70393-03	70393-04	70393-05
6	Dowel Pin	4	PA7497	PA7497	PA7497	PA7497
7	Hex Head Bolt	4	35-12-52C	35-12-52C	35-12-52C	35-12-52C
8	Lockwasher	4	17-12C	17-12C	17-12C	17-12C
9	Bearing	1	PA7451	PA7451	PA7451	PA7451
10	Retaining Ring	1	PA7456	PA7456	PA7456	PA7456
11	Retaining Ring	1	PA7455	PA7455	PA7455	PA7455
12	Gasket	1	70139	70139	70139	70139
13	Enclosure	1	70138-01	70138-01	70138-01	70138-01
14	Gasket	1	58531	58531	58531	58531
15	Cover	1	52823	52823	52823	52823
16	Hex Head Bolt	6	35-4-6C	35-4-6C	35-4-6C	35-4-6C
17	Lockwasher	7	17-4C	17-4C	17-4C	17-4C
18	Captive Screw	6	58597	58597	58597	58597
19	Retaining Ring	6	PA6634	PA6634	PA6634	PA6634
20	Overload Cut-off 7½ Ton	1	39173-04	39173-04	39173-04	39173-04
20	Overload Cut-off 10 Ton	1	39174-04	39174-04	39174-04	39174-04
21	Keeper Plate	1	53219	53219	53219	53219
22	Roll Pin	1	PA4607	PA4607	PA4607	PA4607
23	Hex Head Bolt	1	35-4-8C	35-4-8C	35-4-8C	35-4-8C
24	Sheave Mounting Unit	1	70338	70338	70338	70338
25	Pin	1	69717-01	69717-01	69717-01	69717-01
26	Cotter Pin	2	PA1364	PA1364	PA1364	PA1364
27	Sheave Hanger	1	70361	70361	70361	70361
28	Pin	1	69747	69747	69747	69747
29	Cotter Pin	2	PA1771	PA1771	PA1771	PA1771
30	Polyamide Equalizing Sheave with Bearing	1	70150	70150	70150	70150
30	Steel Equalizing Sheave with Bearing	1	70199	70199	70199	70199
31*	Wire Rope Assembly (a)	1	70147-22	70147-23	70147-24	70147-25
32	Grommet	2	PA7409	PA7409	PA7409	PA7409
33	Dowel Pin	2	PA7487	PA7487	PA7487	PA7487
34	Hex Head Bolt	10	35-10-32	35-10-32	35-10-32	35-10-32
35	Lockwasher	10	17-10C	17-10C	17-10C	17-10C
36	Hex Nut	4	22-12C	22-12C	22-12C	22-12C
37	Pin	1	PA5342	PA5342	PA5342	PA5342

*Recommended Spare Parts

NOTE: (a) Part numbers shown for Item 31, Wire Rope Assembly, are for standard hoists using 1/2 dia. 6x37 XIP wire rope. For special hoists using other size or type wire rope, refer to the wire rope part number listed in additional pages included with this manual; or contact Acco/Harrington of the hoist.

PARTS LIST - PRODUCT SERIES 35

SUSPENSION - 4PD REEVING

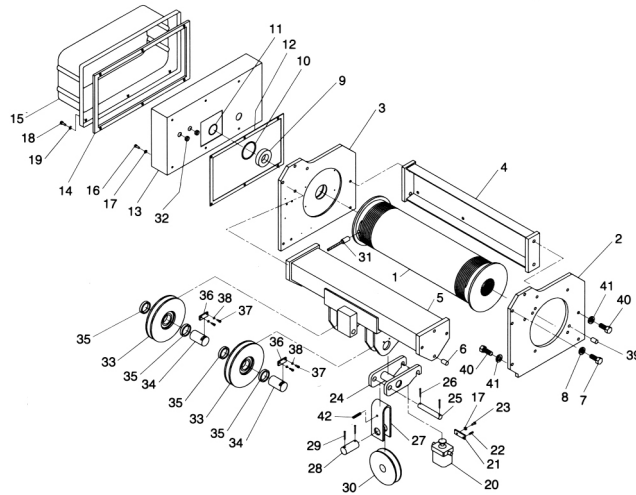

4PD SUSPENSION PARTS

ITEM NO.	DESCRIPTION	QTY.	24 FT. LIFT PART NO.	39 FT. LIFT PART NO.	58 FT. LIFT PART NO.
1	Drum, Double Grooving	1	70313-04	70313-05	70313-06
2	End Plate, Gear End	1	70310	70310	70310
3	End Plate, Control End	1	70311	70311	70311
4	Side Frame	1	70172-04	70172-15	70172-16
5	Frame Unit	1	70327-04	70327-05	70327-06
6	Dowel Pin	4	PA7497	PA7497	PA7497
7	Hex Head Bolt	4	35-12-36	35-12-36	35-12-36
8	Lockwasher	4	17-12C	17-12C	17-12C
9	Bearing	1	PA7451	PA7451	PA7451
10	Retaining Ring	1	PA7456	PA7456	PA7456
11	Retaining Ring	1	PA7455	PA7455	PA7455
12	Gasket	1	70139	70139	70139
13	Enclosure	1	70138-01	70138-01	70138-01
14	Gasket	1	58531	58531	58531
15	Cover	1	52823	52823	52823
16	Hex Head Bolt	6	35-4-6C	35-4-6C	35-4-6C
17	Lockwasher	7	17-4C	17-4C	17-4C
18	Captive Screw	6	58597	58597	58597
19	Retaining Ring	6	PA6634	PA6634	PA6634
20	Overload Cut-off 15 Ton	1	39173-04	39173-04	39173-04
20	Overload Cut-off 20 Ton	1	39173-04	39173-04	39173-04
21	Keeper Plate	1	53219	53219	53219
22	Roll Pin	1	PA4607	PA4607	PA4607
23	Hex Head Bolt	1	35-4-8C	35-4-8C	35-4-8C
24	Sheave Mounting Unit	1	70357	70357	70357
25	Pin	1	69717-01	69717-01	69717-01
26	Cotter Pin	2	PA1364	PA1364	PA1364
27	Sheave Hanger	1	70361	70361	70361
28	Pin	1	69747	69747	69747
29	Cotter Pin	2	PA1771	PA1771	PA1771
30	Polyamide Equalizing Sheave with Bearing	1	70150	70150	70150
30	Steel Equalizing Sheave with Bearing	1	70199	70199	70199
31*	Wire Rope Assembly (a)	1	70147-34	70147-35	70147-36
32	Grommet	2	PA7409	PA7409	PA7409
33	Polyamide Running Sheave with Bearing	2	69567	69567	69567
33	Steel Running Sheave with Bearing	2	69568	69568	69568
34	Axle	2	69686-02	69686-02	69686-02
35	Spacer	4	69569-02	69569-02	69569-02
36	Keeper Plate	2	50733	50733	50733
37	Screw	4	1-01-8	1-01-8	1-01-8
38	Lockwasher	4	17-010C	17-010C	17-010C
39	Dowel Pin	2	PA7487	PA7487	PA7487
40	Hex Head Bolt	10	35-10-32	35-10-32	35-10-32
41	Lockwasher	10	17-10C	17-10C	17-10C
42	Pin	1	PA5342	PA5342	PA5342

*Recommended Spare Parts

NOTES: (a) Part numbers shown for Item 31, Wire Rope Assembly, are for standard hoists using 1/2 dia. 6x37 XIP wire rope. For special hoists using other size or type wire rope, refer to the wire rope part number listed in additional pages included with this manual; or contact Acco/Harrington or the distributor of the hoist.

PARTS LIST - PRODUCT SERIES 35

LOAD BLOCK - 2PS REEVING 3/4" ROPE DIAMETER

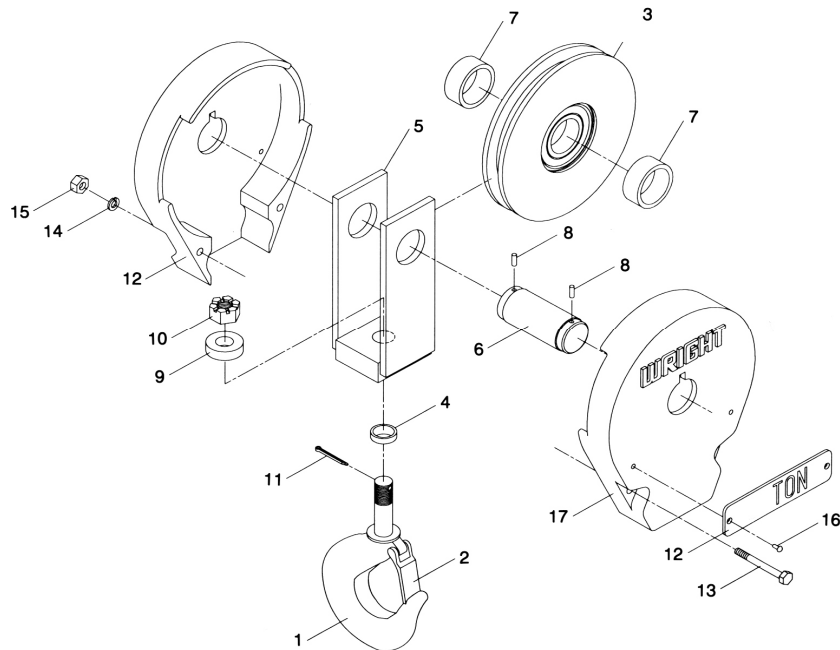

- Load Block Assembly 69553-01 – Acco/Harrington Spring Latch Type Hook, Polyamide Sheave
- Load Block Assembly 69553-02 - Bullard Swivel Latch Type Hook, Polyamide Sheave
- Load Block Assembly 69553-03 - Bronze Spring Latch Type Hook, Polyamide Sheave
- Load Block Assembly 69553-04 – Acco/Harrington Spring Latch Type Hook, Steel Sheave
- Load Block Assembly 69553-05 - Bullard Swivel Latch Type Hook, Steel Sheave
- Load Block Assembly 69553-06 - Bronze Spring Latch Type Hook, Steel Sheave

LOAD BLOCK PARTS

ITEM NO.	DESCRIPTION	QUANTITY	PART NO.
1	Hook	1	(a)
2	Latch	1	(b)
3	Sheave	1	(c)
4	Spacer	0	(d)
5	Frame	1	69577
6	Axle	1	69578
7	Spacer	2	69581
8	Roll Pin	2	PA4607
9	Thrust Bearing	1	PA5832
10	Slotted Hex Nut	1	26-24
11	Cotter Pin	1	PA1932
12	Cover	2	69583
13	Hex Head Bolt	2	35-8-52
14	Lockwasher	2	17-8C
15	Hex Nut	2	22-8
16	Drive Screw	4	PA893
17	Capacity Plate	2	(e)

NOTES:

- (a) Hook part numbers:
 Acco/Harrington Spring Latch Type Hook..... 58012
 Bullard Swivel Latch Type Hook..... 58013
 Bronze Spring Latch Type Hook..... 58014
- (b) Latch part numbers:
 Latch for Acco/Harrington Spring Latch Type Hook .PA5327
 No latch required for Bullard Swivel Latch Type Hook Latch for
 Bronze Spring Latch Type Hook PA5329
- (c) Sheave part numbers:
 Polyamide sheave with bearing..... 69579
 Steel sheave with bearing 69580
- (d) Item 4 not required.
- (e) Capacity Plate part numbers: 5
 Ton - 69683-050
 7½ Ton - 69683-075
 10 Ton - 69683-100

No Recommended Spare Parts

PARTS LIST - PRODUCT SERIES 35

LOAD BLOCK - 4PS REEVING 3/4" ROPE DIAMETER

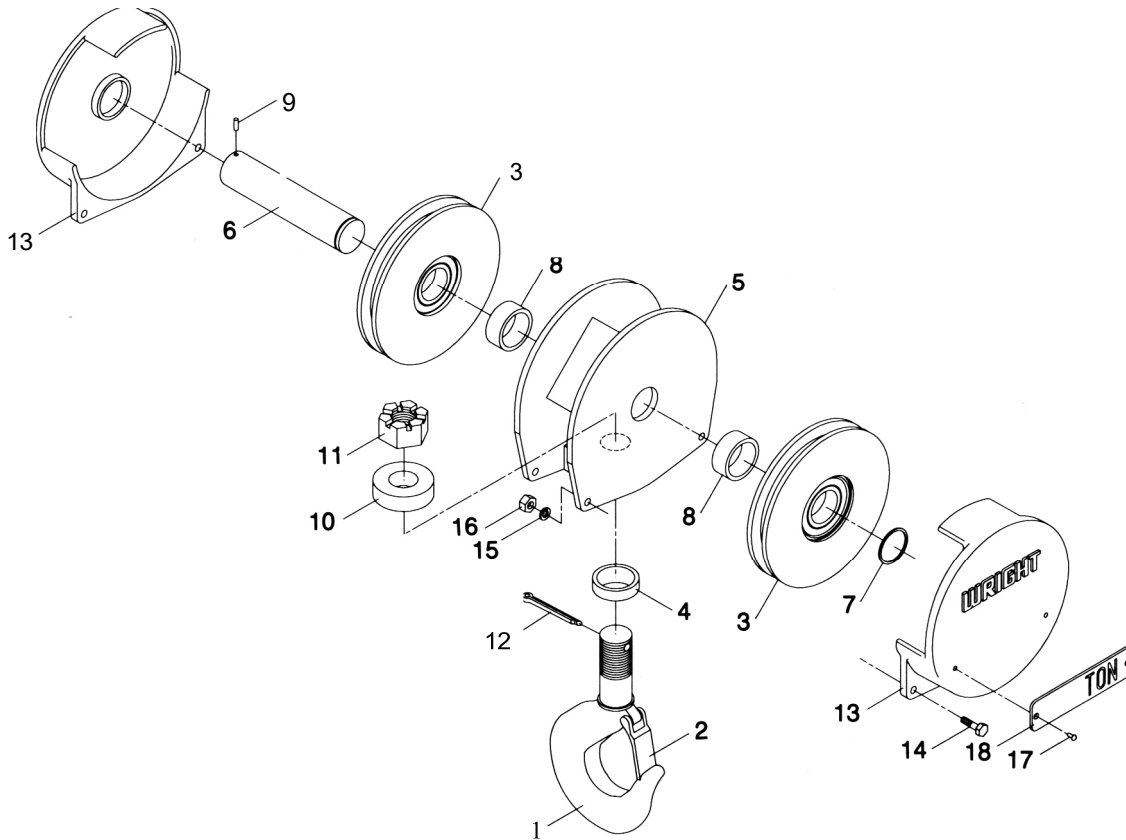

Load Block Assembly 69557-01 - Acco Spring Latch Type Hook, Polyamide Sheave
 Load Block Assembly 69557-02 - Acco Spring Latch Type Hook, Steel Sheave

LOAD BLOCK PARTS

ITEM NO.	DESCRIPTION	QUANTITY	PART NO.
1	Hook	1	43577
2	Latch	1	PA5329
3	Sheave	2	(c)
4	Spacer	0	(d)
5	Frame	1	69603
6	Axle	1	69604
7	Retaining Ring	1	PA7379
8	Spacer	2	69581
9	Roll Pin	1	PA4607
10	Thrust Bearing	1	PA1248
11	Slotted Hex Nut	1	26-32
12	Cotter Pin	1	PA3796
13	Cover	2	69606
14	Hex Head Bolt	4	35-8-40
15	Lockwasher	4	17-8C
16	Hex Nut	4	22-8
17	Drive Screw	4	PA893
18	Capacity Plate	2	(e)

NOTES:

- (c) Sheave part numbers:
 Polyamide sheave with bearing.....69579
 Steel sheave with bearing69580
- (d) Item 4 not required.
- (e) Capacity Plate part numbers:
 10 Ton - 69683-100
 15 Ton - 69683-150
 20 Ton - 69683-200

No Recommended Spare Parts

PARTS LIST - PRODUCT SERIES 35

LOAD BLOCK – 2PD REEVING 1/2" ROPE DIAMETER

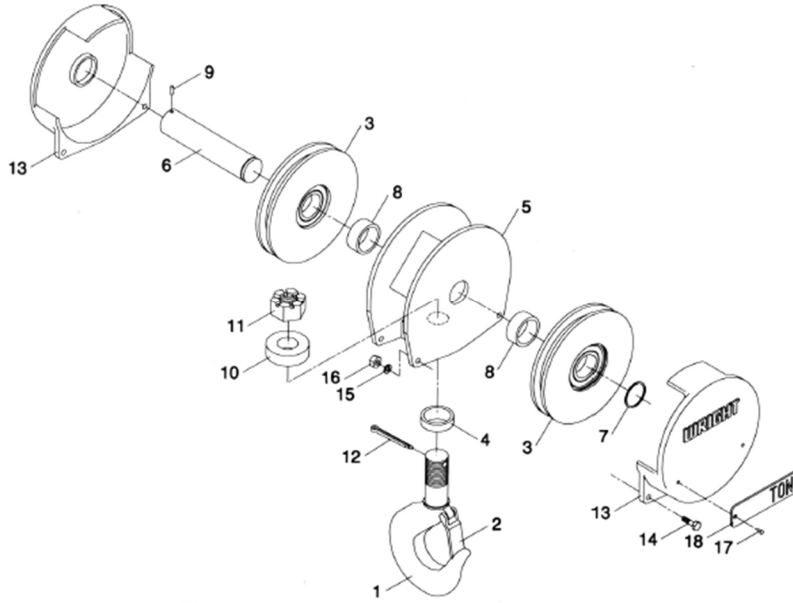

- Load Block Assembly 69555-01 – Acco/Harrington Spring Latch Type Hook, Polyamide Sheave
- Load Block Assembly 69555-02 - Bullard Swivel Latch Type Hook, Polyamide Sheave
- Load Block Assembly 69555-03 - Bronze Spring Latch Type Hook, Steel Sheave
- Load Block Assembly 69555-04 – Acco/Harrington Spring Latch Type Hook, Steel Sheave
- Load Block Assembly 69555-05 - Bullard Swivel Latch Type Hook, Steel Sheave
- Load Block Assembly 69555-06 - Bronze Spring Latch Type Hook, Steel Sheave

LOAD BLOCK PARTS

ITEM NO.	DESCRIPTION	QUANTITY	PART NO.
1	Hook	1	(a)
2	Latch	1	(b)
3	Sheave	2	(c)
4	Spacer	0	(d)
5	Frame	1	69591
6	Axle	1	69592
7	Retaining Ring	1	PA6941
8	Spacer	2	69569
9	Roll Pin	1	PA4607
10	Thrust Bearing	1	PA5832
11	Slotted Hex Nut	1	26-24
12	Cotter Pin	1	PA1932
13	Cover	2	69594
14	Hex Head Bolt	4	35-6-32
15	Lockwasher	4	17-6C
16	Hex Nut	4	22-6
17	Drive Screw	4	PA893
18	Capacity Plate	2	(e)

NOTES:

- (a) Hook part numbers:
 Acco/Harrington Spring Latch Type Hook 58012
 Bullard Swivel Latch Type Hook with nut.....58013
 Bronze Spring Latch Type Hook..... 58014
- (b) Latch part numbers:
 Latch for Acco/Harrington Spring Latch Type Hook..PA5327
 No latch required for Bullard Swivel Latch Type Hook
 Latch for Bronze Spring Latch Type Hook.....PA5329
- (c) Sheave part numbers:
 Polyamide sheave with bearing 69567
 Steel sheave with bearing 69568
- (d) Item 4 not required.
- (e) Capacity Plate part numbers:
 5 Ton - 69683-050
 7½ Ton - 69683-075
 10 Ton - 69683-100

No Recommended Spare Parts

PARTS LIST - PRODUCT SERIES 35

LOAD BLOCK - 4PD REEVING 1/2" ROPE DIAMETER

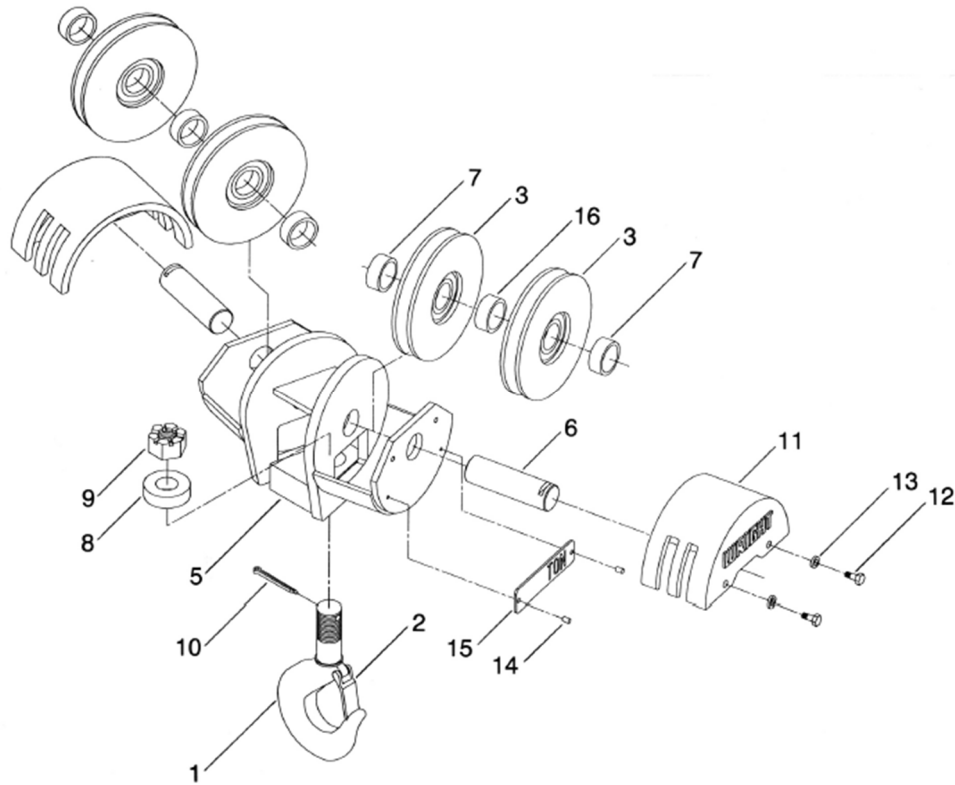

Load Block Assembly 69559-01 – Acco/Harrington Spring Latch Type Hook, Polyamide Sheave
 Load Block Assembly 69559-02 – Acco/Harrington Spring Latch Type Hook, Steel Sheave

LOAD BLOCK PARTS

ITEM NO.	DESCRIPTION	QUANTITY	PART NO
1	Hook	1	43577
2	Latch	1	PA5329
3	Sheave	4	(a)
4	Spacer	0	(b)
5	Frame	1	69677
6	Axle	2	69686
7	Spacer	4	69569-04
8	Thrust Bearing	1	PA1248
9	Slotted Hex Nut	1	26-32
10	Cotter Pin	1	PA3796
11	Cover	2	69673
12	Hex Head Bolt	4	35-6-12C
13	Lockwasher	4	17-6C
14	Drive Screw	4	PA893
15	Capacity Plate	2	(c)
16	Spacer	2	69569-03

NOTES:

- (a) Sheave part numbers:
 Polyamide sheave with bearing..... 69567
 Steel sheave with bearing 69568
- (b) Item 4 not required and not shown.
- (c) Capacity Plate part numbers:
 10 Ton - 69683-100
 15 Ton - 69683-150
 20 Ton - 69683-200

No Recommended Spare Parts

PARTS LIST - PRODUCT SERIES 35

GRAVITY LIMIT SWITCH

Gravity Limit Switch Assembly 70265-01 - Used on Series 32 and Series 33 2PS, 2PD, and 4PD hoists.

Gravity Limit Switch Assembly 70265-02 - Used on Series 33 4PS, Series 34, and Series 35 hoists.

GRAVITY LIMIT SWITCH PARTS				
ITEM NO.	PART NO.	DESCRIPTION	QTY. 70265-01	QTY. 70265-02
1	70262	Enclosure	1	1
2	PA3598	Bushing	(a)	(a)
3	69793	Arm	1	1
4	3-08-4C	Screw	1	1
5	70264	Cam	1	1
6	3-05-14C	Screw	2	2
7	PA7400	Spring	1	1
8	3-05-2C	Screw	3	3
9	3-010-6C	Screw	1	1
10	61717	Switch Unit	1	1
11	70263	Shaft	1	1
12	64104	Insulator	1	1
13	PA3810	Spring Pin	1	1
14	PA5155	Self-tapping Screw	2	2
15	69804	Cover	1	1
16	69805	Gasket	1	1
17	PA2242	Oval Cable Sleeve	2	2
18	PA3113	Wire Rope	A.R.	A.R.
19	69827	Weight Half	2	0
20	35-4-16C	Bolt	2	0
21	22-4C	Hex Nut	2	2
22	17-4C	Lockwasher	2	2
23	19-08C	Lockwasher, Int. Tooth	1	1
24	3-010-6C	Screw	0	1
25	3-01C	Hex Nut	0	1
26	35-4-24C	Bolt	0	2
27	A2007L1	Weight Half, Left	0	1
28	A2007R1	Weight Half, Right	0	1

No Recommended Spare Parts

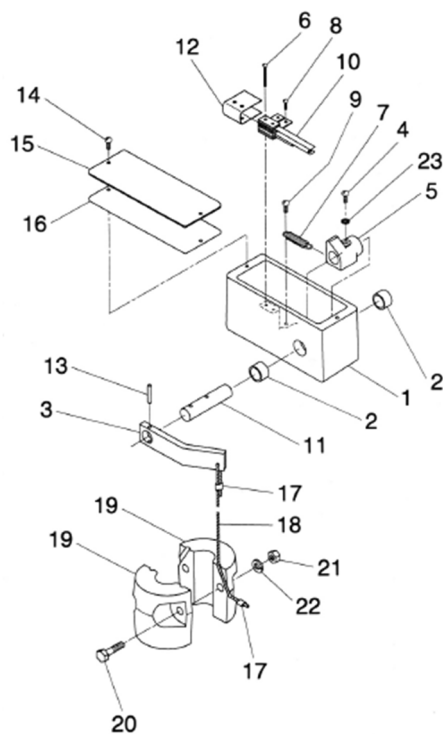

ASSEMBLY-01

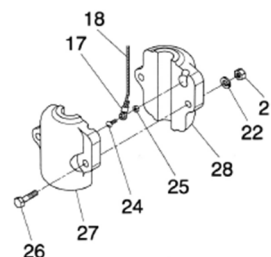

ASSEMBLY-02

NOTES:

- (a) Included with Item 1.
- (b) Gravity limit switch attached to hoist frame with two (2) Round Head Screws, Part No. 3-010-14C, and two (2) Locknuts, Part No. PA2423.

PARTS LIST - PRODUCT SERIES 35

GEARED LIMIT SWITCH

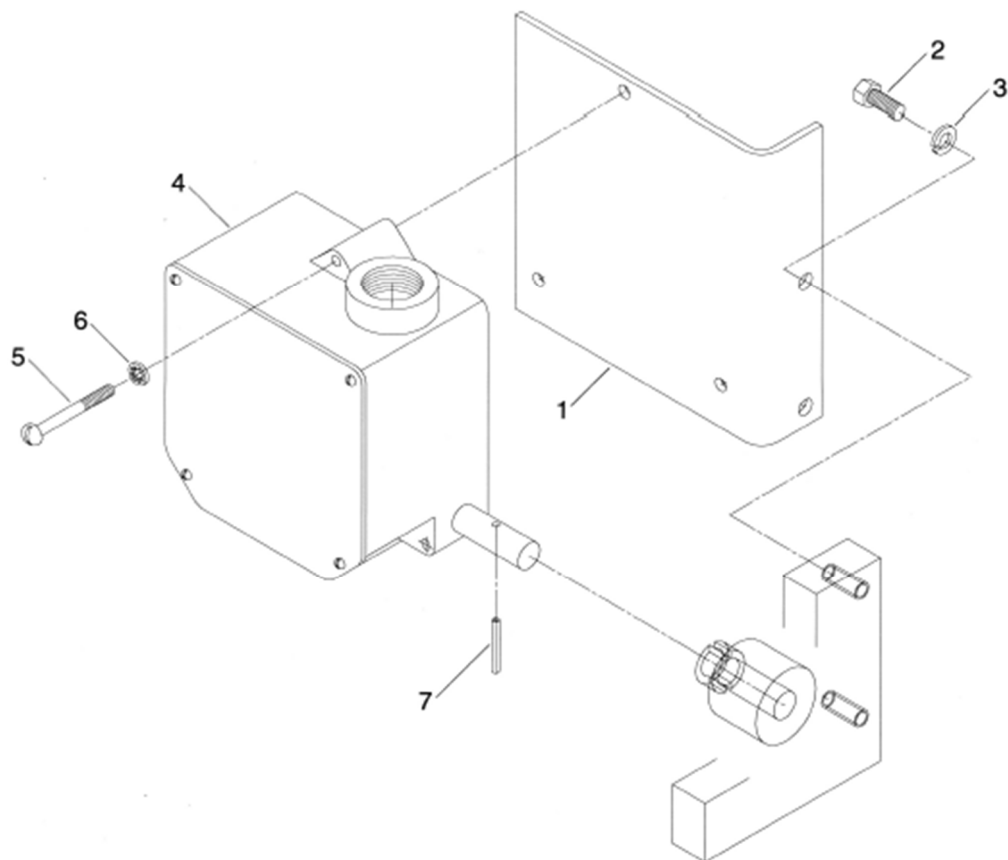

GEARED LIMIT SWITCH PARTS

ITEM NO.	PART NO.	DESCRIPTION	QTY.
1	70173	Mounting Plate	1
2	35-4-8C	Hex Head Bolt	2
3	17-4C	Lockwasher	2
4	61649-01	Geared Limit Switch 2 Circuit - 111:1 Ratio	1
4	61649-03	Geared Limit Switch 4 Circuit - 111:1 Ratio	1
4	61649-02	Geared Limit Switch 2 Circuit - 320:1 Ratio	1
4	61649-04	Geared Limit Switch 4 Circuit - 320:1 Ratio	1
5	3-010-24C	Round Head Screw	3
6	19-010C	Lockwasher	3
7	PA3810	Drive Pin	1

No Recommended Spare Parts

PARTS LIST - PRODUCT SERIES 35

HOIST RECTIFIED D.C. BRAKE CONTROL

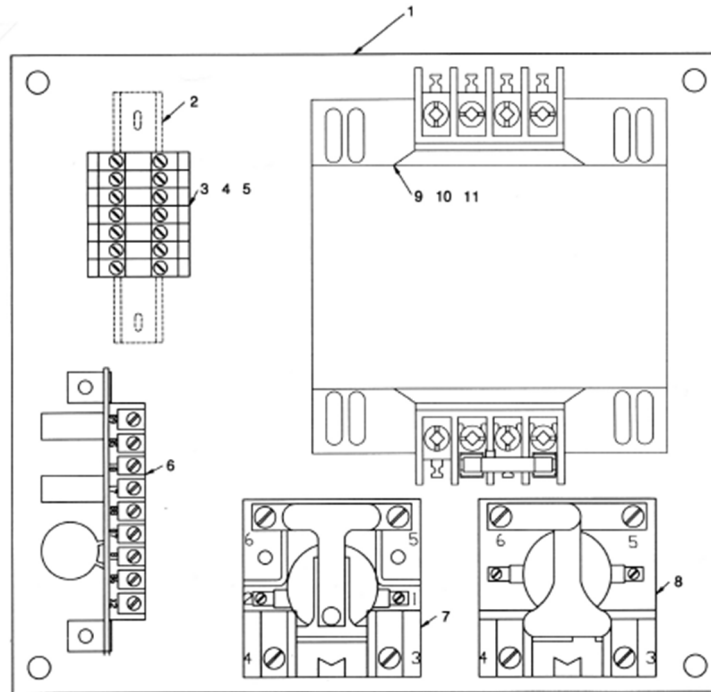

REPLACEMENT PARTS

ITEM NO.	PART NUMBER	DESCRIPTION
1	86828	Panel, Drilled
2	86714-12	Din Rail, Pre-cut, 3-1/2" L.
3	86710-05	Terminal, End Anchor
4	86710-07	Terminal, End Barrier
5	86710-01	Terminal, Control
6*	86712	Brake Circuit Control Board
7*	PA6496	Relay, Brake Ctrl. (BC) for 115V. Control
	PA6373	Relay, Brake Ctrl. (BC) for 24V. Control

*Recommended Spare Parts

ITEM NO.	PART NUMBER	DESCRIPTION
8*	PA6254	Relay, Brake (BR) for 115V. Control
	PA6255	Relay, Brake (BR) for 24V. Control
9	52429-80	Transformer Fuse Holder
10*	PA6334	Transformer Fuse (350VA)
	PA6335	Transformer Fuse (500VA)
11	52429-09	Transformer, 350VA, 200-115
	52429-21	Transformer, 350VA, 230/460-115
	52429-44	Transformer, 350VA, 575-115
	52429-10	Transformer, 500VA, 200-115
	52429-22	Transformer, 500VA, 230/460-115
	52429-45	Transformer, 500VA, 575-115

PARTS LIST - PRODUCT SERIES 35

BASIC CONTROL COMPONENTS

SINGLE OR TWO SPEED HOIST, LUG MTD., PLAIN OR GEARED TROLLEY OR SINGLE SPEED HOIST SINGLE SPEED TROLLEY COMBINATION

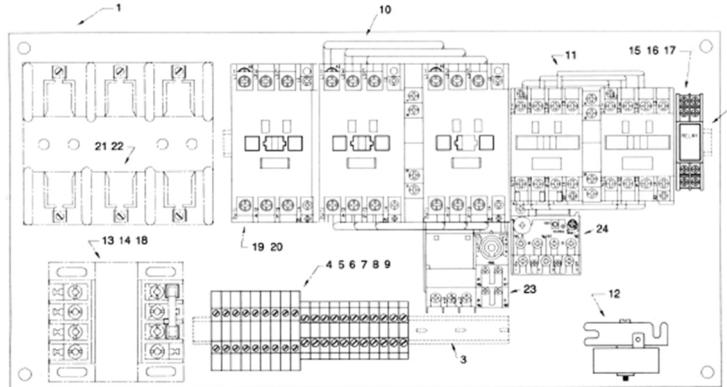

REPLACEMENT PARTS

ITEM NO.	PART NUMBER	DESCRIPTION
1	86822	Panel, Drilled
2	86714-06	DIN Rail, Pre-cut, 12"
3	86714-02	DIN Rail, Pre-cut, 8"
4	86710-04	Terminal, Grounding
5	86710-05	Terminal, End Anchor
6	86710-06	Terminal, End Barrier, Power
7	86710-07	Terminal, End Barrier, Control
8	86710-01	Terminal, Control
9	86710-02	Terminal, Power
10*	86702-01	Contactors, Reversing, (or Two Speed) 115 V (Hoist) Size C, For Two Speed Contactor remove load side jumper wires (black wires)
	86702-02	Contactors, Reversing, (or Two Speed) 24 V (Hoist) Size C, For Two Speed Contactor remove load side jumper wires (black wires)
	86703-01	Contactors, Reversing (or Two Speed) 115 V (Hoist) Size D, For Two Speed Contactor remove load side jumper wires (black wires)
	86703-02	Contactors, Reversing (or Two Speed) 24 V (Hoist) Size D, For Two Speed Contactor remove load side jumper wires (black wires)
11*	86701-01	Contactors, Reversing (or Two Speed) 115 V (Trolley) Size B, For Two Speed Contactor remove load side jumper wires (black wires)
	86701-02	Contactors, Reversing (or Two Speed) 115 V (Trolley) Size B, For Two Speed Contactor remove load side jumper wires (black wires)
12	PA7103	Time Capsule, 115 V (Two Speed Only)
	PA7104	Time Capsule, 24 V (Two Speed Only)

ITEM NO.	PART NUMBER	DESCRIPTION
13	52429-80	Transformer Fuse Clip (24 V controls only)
14*	PA7330	Transformer Fuse (24 V controls only) 50 VA
	PA6334	Transformer Fuse (24 V controls only) 75 VA
15*	PA7382	Relay, Control, 115 V (Two Speed Only)
	PA7383	Relay, Control, 24 V (Two Speed Only)
16	PA7384	Relay, Socket
17	PA7385	Relay, Retainer Clip
18	52429-XX	Transformer (24 V controls only) -52 for 200 V; -26 for 230/460 V; -64 for 575 V Supply (50 VA)
	52429-XX	Transformer (24 V controls only) -53 for 200 V; -27 for 230/460 V; -65 for 575 V Supply (75 VA)
19	86704-01	Mainline Contactor, 115 V Size C (Optional)
	86704-02	Mainline Contactor, 24 V Size C (Optional)
	86705-01	Mainline Contractor, 115 V Size D (Optional)
	86705-02	Mainline Contactor, 24 V Size D (Optional)
20	86708-02	Contact Block, Aux. (used with Mainline Contactor)
21	PA7341	Fuse Block, Mtr. Ckt. 30A. (Optional)
	PA7342	Fuse Block, Mtr. Ckt. 60A. (Optional)
22*	86709-XX	Fuse, Mtr. Ckt. (Optional) see note below
23	86706-XX	Overload Relay, Hoist (Optional) see note below
24	86706-XX	Overload Relay, Trolley (Optional) see note below
Not Shown	69505-02	Danger Label, Electrical

*Recommended Spare Parts

NOTE:

When ordering Motor Circuit Fuses or Overload Relays, provide as much information about the hoist as possible. Hoist serial number, motor H.P's., full load currents, supply voltage, etc.

PARTS LIST - PRODUCT SERIES 35

BASIC CONTROL COMPONENTS

SINGLE OR TWO SPEED HOIST AND TROLLEY CONTROL WITH ACM & SIZE "C" HOIST CONTACTOR

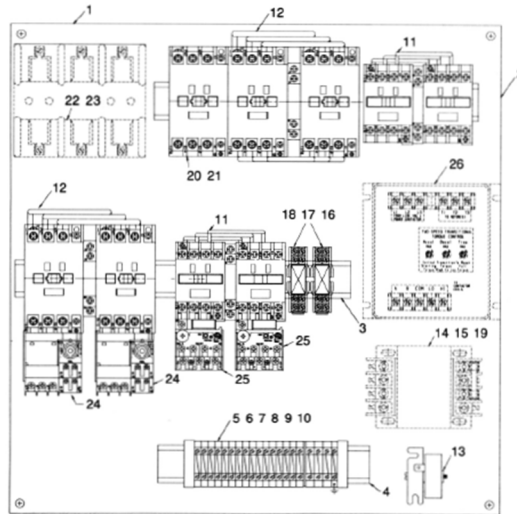

REPLACEMENT PARTS

ITEM NO.	PART NUMBEP.	DESCRIPTION
1	86824	Panel, Drilled .
2	86714-11	DIN Rail, Pre-cut, 13" L.
3	86714-10	DIN Rail, Pre-cut, 12.5" L.
4	86714-02	DIN Rail, Pre-Cut, 8" L.
5	86710-04	Terminal, Grounding
6	86710-05	Terminal, End Anchor
7	86710-06	Terminal, End Barrier, Power
8	86710-07	Terminal, End Barrier, Control
9	86710-01	Terminal, Control
10	86710-02	Terminal, Power
11*	86701-01	Contact, Reversing, (or Two Speed) 115 V (Trolley) Size B, For Two Speed Contactor remove load side jumper wires (black wires)
	86701-02	Contact, Reversing, (or Two Speed) 24 V (Trolley) Size B, For Two Speed Contactor remove load side jumper wires (black wires)
12*	86702-01	Contact, Reversing, (or Two Speed) 115 V (Hoist) Size C, For Two Speed Contactor remove load side jumper wires (black wires)
	86702-02	Contact, Reversing, (or Two Speed) 24 V (Hoist) Size C, For Two Speed Contactor remove load side jumper wires (black wires)
13	PA7103	Time Capsule, 115 V (Two Speed Only)
	PA7104	Time Capsule, 24 V (Two Speed Only)
14	52429-80	Transformer Fuse Clip (24 V Models Only)
15*	PA7330	Transformer Fuse (24 V Models Only)

ITEM NO.	PART NUMBER	DESCRIPTION
16	PA7382	Relay, Control, 115 V (Two Speed Only)
	PA7383	Relay, Control, 24 V (Two Speed Only)
17	PA7384	Relay, Socket (Two Speed Only)
18	PA7385	Relay, Hold Down Clip
19	52429-XX	Transformer (24 V controls only) -52 for 200 V; -26 for 230/460 V; -64 for 575 V Supply (50 VA)
20	86704-01	Mainline Contactor, 115 V Size C (Optional)
	86704-02	Mainline Contactor, 24 V Size C (Optional)
21	86708-02	Contact Block, Aux. (used with Mainline Contactor)
22	PA7341	Fuse Block, Motor Ckt. 30A. (Optional)
	PA7342	Fuse Block, Motor Ckt. 60A. (Optional)
23*	86709-XX	Fuse, Motor Circuit (Optional) see note below
24	86706-XX	Overload Relay, Hoist (Optional) see note below
25	86706-XX	Overload Relay, Trolley (Optional) see note below
26	86715-017	ACM, S.S. 1 H.P. 200-230 V 2 H.P. Max. 460 V
	86715-019	ACM, S.S. 2.5 H.P. 200-230 V 5 H.P. Max. 460 V
	86715-018	ACM, 2S. 1 H.P. 200-230 V 2 H.P. Max. 460 V
	86715-020	ACM, 2S. 2.5 H.P. 200-230 V 5 H.P. Max. 460 V
	86715-002	ACM, S.S. 2 H.P. Max. 575 V
	86715-004	ACM, S.S. 5 H.P. Max. 575 V
	86715-006	ACM, 2S. 2 H.P. Max. 575 V
	86715-008	ACM, 2S. 5 H.P. Max. 575 V
Not Shown	69505-02	Danger Label, Electrical

*Recommended Spare Parts

NOTE:

When ordering Motor Circuit Fuses or Overload Relays, provide as much information about the hoist as possible. Hoist serial number, motor H.P.'s., full load currents, supply voltage, etc. ACM's listed are for 115 V control only. For 24 V control, order by description.

PARTS LIST - PRODUCT SERIES 35

BASIC CONTROL COMPONENTS

SINGLE OR TWO SPEED HOIST AND TROLLEY CONTROL WITH SIZE "D" HOIST CONTACTOR

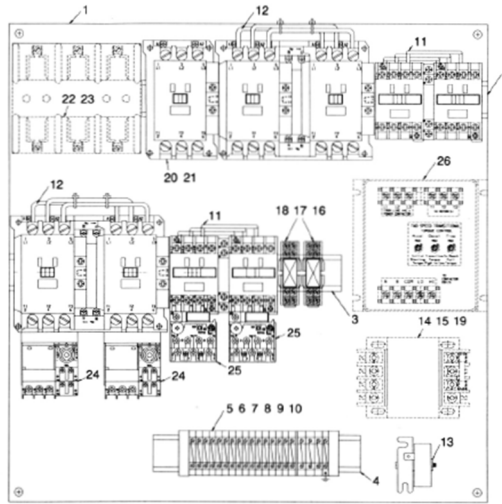

REPLACEMENT PARTS

ITEM NO.	PART NUMBER	DESCRIPTION
1	86824	Panel, Drilled
2	86714-11	DIN Rail, Pre-cut, 13" L.
3	86714-10	DIN Rail, Pre-cut, 12.5" L.
4	86714-02	DIN Rail, Pre-Cut, 811 L.
5	86710-04	Terminal, Grounding
6	86710-05	Terminal, End Anchor
7	86710-06	Terminal, End Barrier, Power
8	86710-07	Terminal, End Barrier, Control
9	86710-01	Terminal, Control
10	86710-02	Terminal, Power
11*	86701-01	Contactors, Reversing, (or Two Speed) 115 V (Trolley) Size 8, For Two Speed Contactor remove load side jumper wires (black wires)
	86701-02	Contactors, Reversing, (or Two Speed) 24 V (Trolley) Size 8, For Two Speed Contactor remove load side jumper wires (black wires)
12*	86703-01	Contactors, Reversing, (or Two Speed) 115 V (Hoist) Size D, For Two Speed Contactor remove load side jumper wires (black wires)
	86703-02	Contactors, Reversing, (or Two Speed) 24 V (Hoist) Size D, For Two Speed Contactor remove load side jumper wires (black wires)
13	PA7103	Time Capsule, 115 V (Two Speed Only)
	PA7104	Time Capsule, 24 V (Two Speed Only)
14	52429-80	Transformer Fuse Clip (24 V Models Only)
15*	PA6335	Transformer Fuse (24 V Models Only)

*Recommended Spare Parts

ITEM NO.	PART NUMBER	DESCRIPTION
16	PA7382	Relay, Control, 115 V (Two Speed Only)
	PA7383	Relay, Control, 24 V (Two Speed Only)
17	PA7384	Relay, Socket (Two Speed Only)
18	PA7385	Relay, Hold Down Clip
19	52429-XX	Transformer (24 V controls only) -54 for 200 V; -28 for 230/460 V; -66 for 575 Supply (100 VA)
20	86705-01	Mainline Contactor, 115 V Size D (Optional)
	86705-02	Mainline Contactor, 24 V Size D (Optional)
21	86708-02	Contact Block, Aux. (used with Mainline Contactor)
22	PA7341	Fuse Block, Motor Ckt., 30A. (Optional)
	PA7342	Fuse, Motor Ckt., 60A. (Optional)
23*	86709-XX	Fuse, Motor Circuit (Optional) see note below
24	86706-XX	Overload Relay, Hoist (Optional) see note below
25	86706-XX	Overload Relay, Trolley (Optional) see note below
26	86715-017	ACM, S.S. 1 H.P. 200-230 V 2 H.P. 460 V
	86715-019	ACM, S.S. 2.5 H.P. 200-230 V 5 H.P. 460 V
	86715-018	ACM, 2S. 1 H.P. 200-230 V 2 H.P. 460 V
	86715-020	ACM, 2S. 2.5 H.P. 200-230 V 5 H.P. 460 V
	86715-002	ACM, S.S. 2 H.P. 575 V
	86715-004	ACM, S.S. 5 H.P. 575 V
	86715-006	ACM, 2S. 2 H.P. 575 V
	86715-008	ACM, 2S. 5 H.P. 575 V
Not Shown	69505-02	Danger Label, Electrical

NOTE:

When ordering Motor Circuit Fuses or Overload Relays, provide as much information about the hoist as possible. Hoist serial number, motor H.P.'s., full load currents, supply voltage, etc. ACM's listed are for 115 V cntrl. only, for 24 V order by description.

PENDANT CONTROL STATION

PENDANT CONTROL STATION PARTS LIST

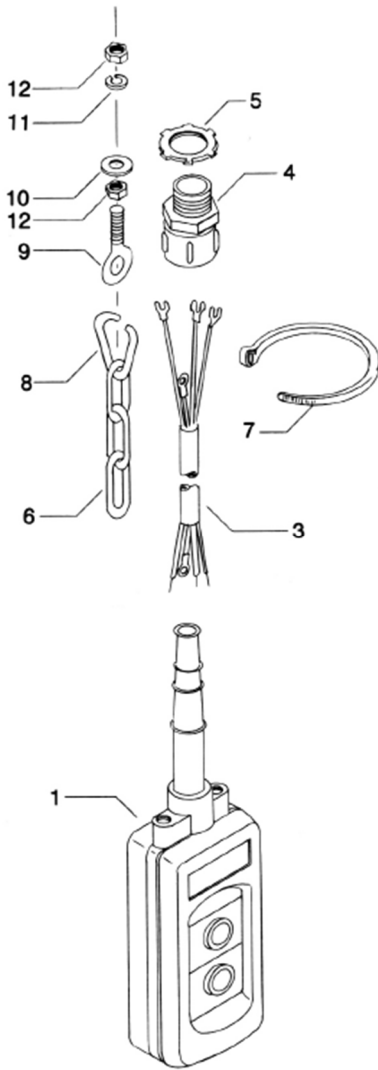

PUSHBUTTON STATION

ITEM NO.	PART NUMBER	DESCRIPTION
1	68898-01	2-Button, Single Speed Pushbutton Station Assembly
	68898-02	2-Button, Two Speed Pushbutton Station Assembly
	86718-02	4-Button, Pushbutton Station, Enclosure only
	86718-03	6-Button, Pushbutton Station Enclosure only
	86718-04	8-Button, Pushbutton Station Enclosure only
2	86718-16	Single Speed Contact Block (not shown)
	86718-19	Two Speed Contact Block (not shown)
	86718-05	Operator Button (Black)
	86718-06	Operator Button (Green)
	86718-07	Operator Button (Red)
3	62046	Cable, 16 Awg., 4 Cond.
	PA2513	Cable, 16 Awg., 8 Cond.
	PA2514	Cable, 16 Awg., 14 Cond.
4	PA2427	Cable Grip, 4 Cond. Cable
	PA2145	Cable Grip, 8 Cond. Cable
	PA2517	Cable Grip, 14 Cond. Cable
5	PA1827	Locknut for PA2427 & PA2145
	PA2036	Locknut for PA2517
6	PA2034	Strain Relief Chain
7	PA6750	Self-Locking Tie
8	PA2035	Chain Repair Link
9	PA5037	Eye Bolt
10	15-4-2C	Washer
11	17-4C	Lockwasher
12	22-4C	Nut
13	63178-01	Warning Label



**WARNING LABEL
63178-01
Replace Label
If Lost or Illegible**

NOTE:

When ordering pushbutton control cable or strain relief chain, specify length in feet. When specifying length of control cable, allow sufficient length to make connections inside of pushbutton station and control enclosure.

PARTS LIST - PRODUCT SERIES 35

PENDANT CONTROL STATION

PENDANT CONTROL STATION PARTS LIST

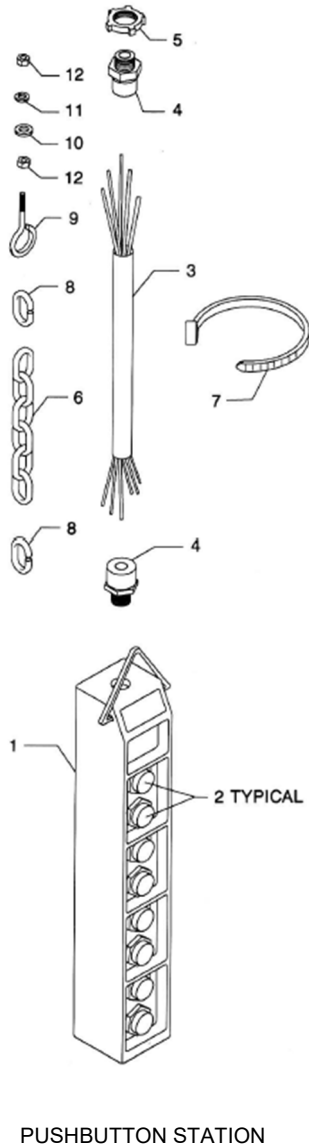

PUSHBUTTON STATION

ITEM NO.	PART NUMBER	DESCRIPTION
1	86716-01	2-Button Enclosure
	86716-02	4-Button Enclosure
	86716-03	6-Button Enclosure
	86716-04	8-Button Enclosure
	86716-05	10-Button Enclosure
2	86716-06	Single Speed Button Assy.
	86716-07	Two Speed Button Assy.
	86716-08	Three Speed Button Assy.
	86716-09	Five Speed Button Assy.
	86716-10	On Button (Green)
	86716-11	Off Button (Red)
	86716-12	Pilot Light (Red)
	86716-13	Two Position Maint. Selector Switch
	86716-14	Three Position Maint. Selector Switch
	86716-15	Push - Pull Operator (Maint.)
	86716-16	Red Mushroom Head Operator (Momentary)
	86716-17	Two Position Keylock Selector (Maint.)
	86716-18	2-Button Maint. Operator (Interlocked)
	86716-19	Contact Block (1 N.O. & 1 N.C.)
	86716-20	Closing Button (For Unused Holes)
86716-21	P.B. Operator (Black, 1 N.O. & 1 N.C.)	
3	62046	Cable, 16 AWG., 4 Cond.
	PA2513	Cable, 16 AWG. 8 Cond.
	PA2514	Cable, 16 AWG., 14 Cond.
	PA6706	Cable, 16 AWG., 24 Cond.
4	PA2427	Cable Grip, 4 Cond. Cable
	PA6652	Cable Grip, 8 Cond. Cable
	PA2517	Cable Grip, 14 Cond. Cable
	PA6705	Cable Grip, 24 Cond. Cable
5	PA1827	Locknut for PA2427 & PA6652
	PA2036	Locknut for PA2517
	PA1828	Locknut for PA6705
6	PA2034	Strain Relief Chain
7	PA6750	Self Locking Tie
8	PA2035	Chain Repair Link
9	PA5037	Eye Bolt
10	15-4-2C	Washer
11	17-4C	Lockwasher
12	22-4C	Nut
13	63178-01	Warning Label



WARNING LABEL
63178-01
Replace Label
If Lost or Illegible

NOTE: When ordering pushbutton control cable or strain relief chain, specify length in feet. When specifying length of control cable, allow sufficient length to make connections inside of pushbutton station and control enclosure.

PARTS LIST - PRODUCT SERIES 35
2-WHEEL PLAIN TROLLEY ASSEMBLY
6 IN. DIAMETER WHEEL
NON-SWIVELING - TWO MOUNTING STUDS

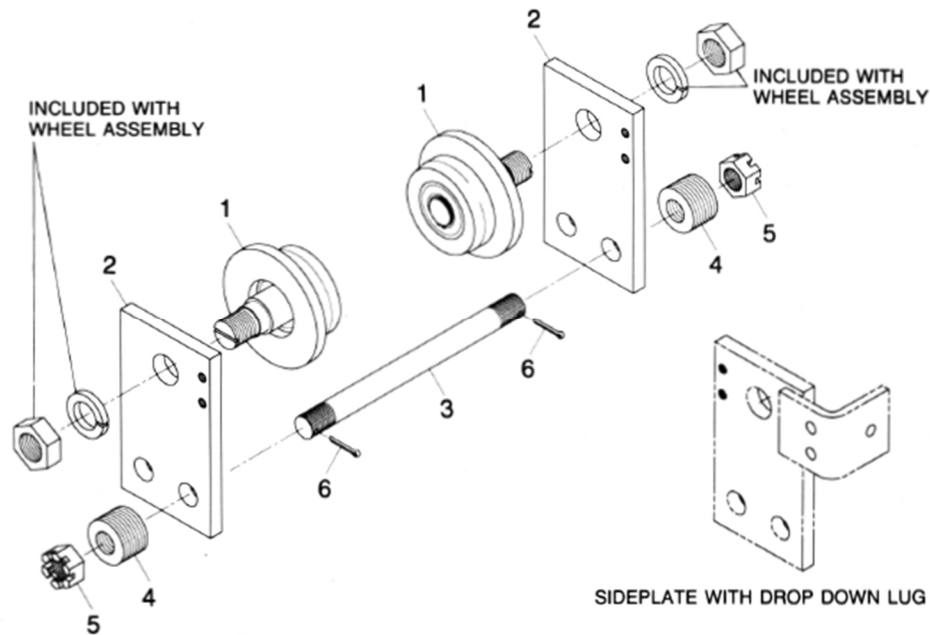

TROLLEY PARTS - 6" DIAMETER WHEELS

TROLLEY ASSEMBLY	BEAM FLANGE WIDTH (Inches)	DROP DOWN LUGS	WHEEL ASSEMBLY		SIDEPLATE	SIDEPLATE	STUD	WASHER		NUT	COTTER PIN	
			2 PER TROLLEY		1 PER TROLLEY	1 PER TROLLEY	2 PER TROLLEY	QTY/TRLY	ITEM 4	4 PER TROLLEY	4 PER TROLLEY	
			MATL.	ITEM 1	ITEM 2	ITEM 2	ITEM 3			ITEM 5	ITEM 6	
69988-01	4-1/2 to 5	No	Steel Dual Tread	69974-01	69986-01	69986-01	69766-04	36	A210-03	26-20	PA1355	
69988-02	5-1/8 to 8				69986-01	69986-01	69766-05					76
69988-03	8-1/8 to 10-1/2				69987-01	69987-01	69766-06					40
69988-04	4-1/2 to 5		Bronze Dual Tread	69974-02	69986-01	69986-01	69766-04					36
69988-05	5-1/8 to 8				69986-01	69986-01	69766-05					76
69988-06	8-1/8 to 10-1/2				69987-01	69987-01	69766-06					40
69988-07	4-1/2 to 5	Yes	Steel Dual Tread	69974-01	69986-02	69986-03	69766-04	36				
69988-08	5-1/8 to 8				69986-02	69986-03	69766-05	76				
69988-09	8-1/8 to 10-1/2				69987-02	69987-03	69766-06	40				
69988-10	4-1/2 to 5		Bronze Dual Tread	69974-02	69986-02	69986-03	69766-04	36				
69988-11	5-1/8 to 8				69986-02	69986-03	69766-05	76				
69988-12	8-1/8 to 10-1/2				69987-02	69987-03	69766-06	40				
69988-13	3-1/4 to 5 (a)	No	Steel Flat	69976-01	69986-01	69986-01	69766-04	36				
69988-14	3-1/4 to 5 (a)		Bronze Flat	69976-02								
69988-15	3-1/4 to 5 (a)	Yes	Steel Flat	69976-01	69986-02	69986-03						
69988-16	3-1/4 to 5 (a)		Bronze Flat	69976-02								

No Recommended Spare Parts

NOTE:

(a) For operation on patented monorail track.

PARTS LIST - PRODUCT SERIES 35

4-WHEEL PLAIN TROLLEY ASSEMBLY 6 IN. DIAMETER WHEEL NON-SWIVELING - ONE MOUNTING STUD

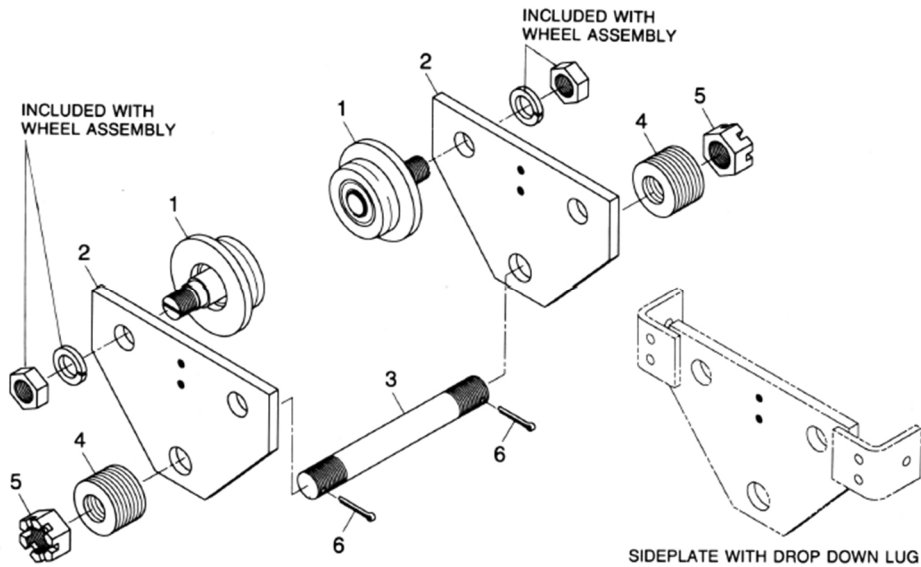

TROLLEY PARTS - 6" DIAMETER WHEELS

TROLLEY ASSEMBLY	BEAM FLANGE WIDTH (Inches)	DROP DOWN LUGS	WHEEL ASSEMBLY		SIDEPLATE	STUD	WASHER		NUT	COTTER PIN
			4 PER TROLLEY		2 PER TROLLEY	1 PER TROLLEY			2 PER TROLLEY	2 PER TROLLEY
			MATL.	ITEM 1	ITEM 2	ITEM 3	QTY/TRLY	ITEM 4	ITEM 5	ITEM 6
69993-01	4-1/2 to 5	No	Steel Dual Tread	69974-01	69979-01	69768-04	16	PA5167	26-32	PA3796
69993-02	5-1/8 to 8				69980-01	69768-05	18			
69993-03	8-1/8 to 10-1/2				69981-01	69768-06	20			
69993-04	4-1/2 to 5		Bronze Dual Tread	69974-02	69979-01	69768-04	16			
69993-05	5-1/8 to 8				69980-01	69768-05	18			
69993-06	8-1/8 to 10-1/2				69981-01	69768-06	20			
69993-07	4-1/2 to 5	Yes	Steel Dual Tread	69974-01	69979-02	69768-04	16			
69993-08	5-1/8 to 8				69980-02	69768-05	18			
69993-09	8-1/8 to 10-1/2				69981-02	69768-06	20			
69993-10	4-1/2 to 5		Bronze Dual Tread	69974-02	69979-02	69768-04	16			
69993-11	5-1/8 to 8				69980-02	69768-05	18			
69993-12	8-1/8 to 10-1/2				69981-02	69768-06	20			
69993-13	3-1/4 to 5 (a)	No	Steel Flat	69976-01	69979-01	69768-04	16			
69993-14	3-1/4 to 5 (a)		Bronze Flat	69976-02						
69993-15	3-1/4 to 5 (a)	Yes	Steel Flat	69976-01	69979-02					
69993-16	3-1/4 to 5 (a)		Bronze Flat	69976-02						

No Recommended Spare Parts

NOTE:

(a) For operation on patented monorail track.

PARTS LIST - PRODUCT SERIES 35

4-WHEEL GEARED TROLLEY ASSEMBLY 6 IN. DIAMETER WHEEL NON-SWIVELING - ONE MOUNTING STUD

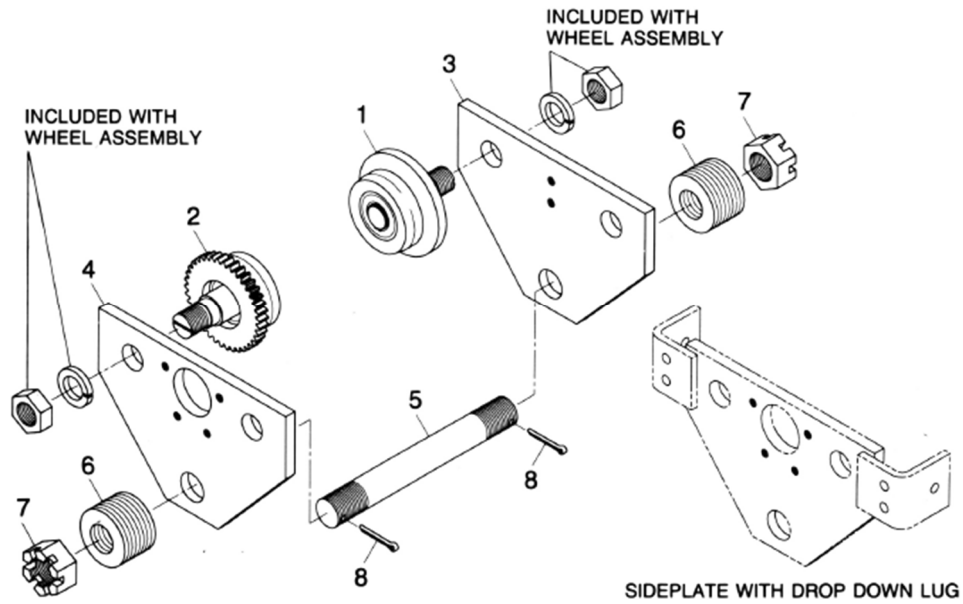

TROLLEY PARTS - 6" DIAMETER WHEELS

TROLLEY ASSEMBLY	BEAM FLANGE WIDTH (Inches)	DROP DOWN LUGS	WHEEL ASSEMBLY			SIDEPLATE	SIDEPLATE	STUD	WASHER		NUT	COTTER PIN
			2 EACH PER TROLLEY			1 PER TROLLEY	1 PER TROLLEY	1 PER TROLLEY	QTY/ TRLY	ITEM 6	2 PER TROLLEY	2 PER TROLLEY
			MATL.	PLAIN ITEM 1	GEARED ITEM 2	ITEM 3	ITEM 4	ITEM 5			ITEM 7	ITEM 8
69994-01	4-1/2 to 5	No	Steel Dual Tread	69974-01	69975-01	69979-01	69982-01	69768-04	16	PA5167	26-32	PA3796
69994-02	5-1/8 to 8					69980-01	69983-01	69768-05	18			
69994-03	8-1/8 to 10-1/2					69981-01	69984-01	69768-06	20			
69994-04	4-1/2 to 5		Bronze Dual Tread	69974-02	69975-02	69979-01	69982-01	69768-04	16			
69994-05	5-1/8 to 8					69980-01	69983-01	69768-05	18			
69994-06	8-1/8 to 10-1/2					69981-01	69984-01	69768-06	20			
69994-07	4-1/2 to 5	Yes	Steel Dual Tread	69974-01	69975-01	69979-02	69982-02	69768-04	16			
69994-08	5-1/8 to 8					69980-02	69983-02	69768-05	18			
69994-09	8-1/8 to 10-1/2					69981-02	69984-02	69768-06	20			
69994-10	4-1/2 to 5		Bronze Dual Tread	69974-02	69975-02	69979-02	69982-02	69768-04	16			
69994-11	5-1/8 to 8					69980-02	69983-02	69768-05	18			
69994-12	8-1/8 to 10-1/2					69981-02	69984-02	69768-06	20			
69994-13	3-1/4 to 5 (a)	No	Steel Flat	69976-01	69977-01	69979-01	69982-01	69768-04	16			
69994-14	3-1/4 to 5 (a)		Bronze Flat	69976-02	69977-02							
69994-15	3-1/4 to 5 (a)	Yes	Steel Flat	69976-01	69977-01	69979-02	69982-02	69768-04	16			
69994-16	3-1/4 to 5 (a)		Bronze Flat	69976-02	69977-02							

No Recommended Spare Parts

NOTE:

(a) For operation on patented monorail track.

PARTS LIST - PRODUCT SERIES 35

4-WHEEL GEARED TROLLEY ASSEMBLY DUAL DRIVE 6 IN. DIAMETER WHEEL NON-SWIVELING - ONE MOUNTING STUD

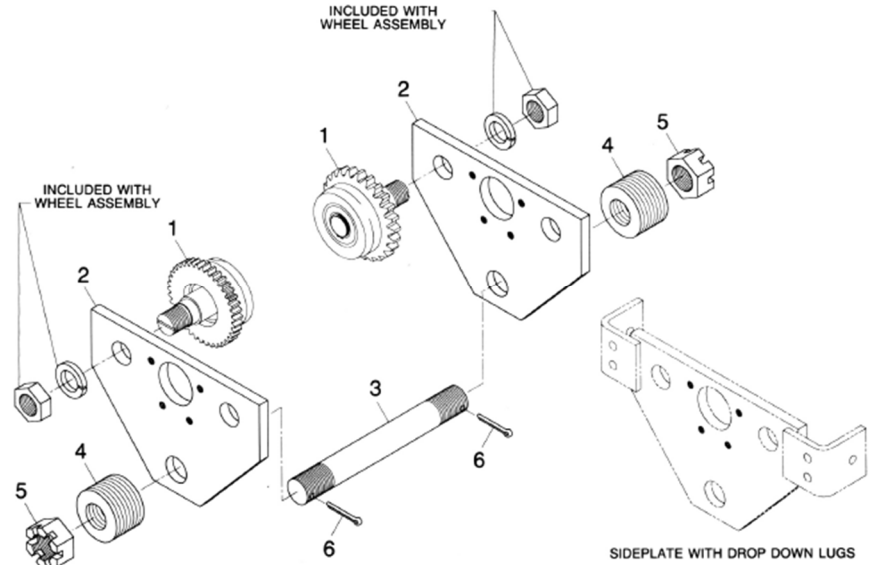

TROLLEY PARTS - 6" DIAMETER WHEELS

TROLLEY ASSEMBLY	BEAM FLANGE WIDTH (Inches)	DROP DOWN LUGS	WHEEL ASSEMBLY		SIDEPLATE	STUD	WASHER		NUT	COTTER PIN
			4 PER TROLLEY		2 PER TROLLEY	1 PER TROLLEY			2 PER TROLLEY	2 PER TROLLEY
			MATL.	ITEM 1	ITEM 2	ITEM 3	QTY/TRLY	ITEM 4	ITEM 5	ITEM 6
69997-01	4-1/2 to 5	No	Steel Dual Tread	69975-01	69982-01	69768-04	16	PA5167	26-32	PA3796
69997-02	5-1/8 to 8				69983-01	69768-05	18			
69997-03	8-1/8 to 10-1/2				69984-01	69768-06	20			
69997-04	4-1/2 to 5		Bronze Dual Tread	69975-02	69982-01	69768-04	16			
69997-05	5-1/8 to 8				69983-01	69768-05	18			
69997-06	8-1/8 to 10-1/2				69984-01	69768-06	20			
69997-07	4-1/2 to 5	Yes	Steel Dual Tread	69975-01	69982-02	69768-04	16			
69997-08	5-1/8 to 8				69983-02	69768-05	18			
69997-09	8-1/8 to 10-1/2				69984-02	69768-06	20			
69997-10	4-1/2 to 5		Bronze Dual Tread	69975-02	69982-01	69768-04	16			
69997-11	5-1/8 to 8				69983-02	69768-05	18			
69997-12	8-1/8 to 10-1/2				69984-02	69768-06	20			
69997-13	3-1/4 to 5 (a)	No	Steel Flat	69977-01	69982-01	69768-04	16			
69997-14	3-1/4 to 5 (a)		Bronze Flat	69977-02						
69997-15	3-1/4 to 5 (a)	Yes	Steel Flat	69977-01	69982-02					
69997-16	3-1/4 to 5 (a)		Bronze Flat	69977-02						

No Recommended Spare Parts

NOTE:

(a) For operation on patented monorail track.

PARTS LIST - PRODUCT SERIES 35

LOADBAR ASSEMBLY – FOR RIGID TROLLEYS

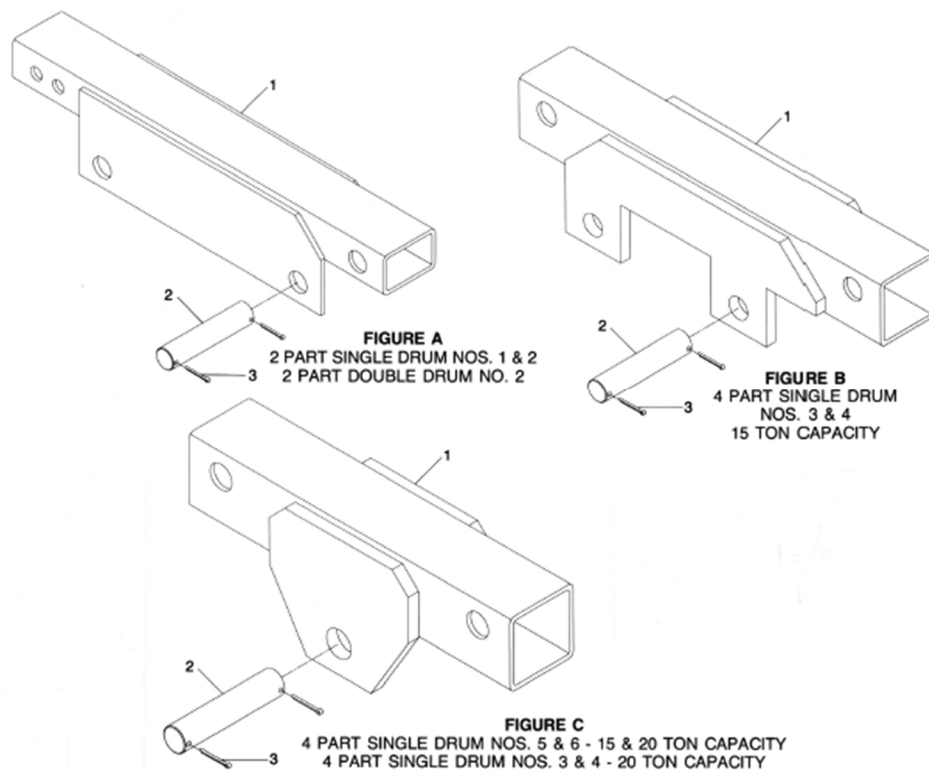

LOADBAR PARTS

ITEM NO.	PART NO.	DESCRIPTION	QTY.
1	70406-01 70406-02 70410 70414-03 70414-04 70407 70166 70166 70166	Loadbar, 2PS, Drum No. 1 Loadbar, 2PS, Drum No. 2 Loadbar, 2PD, Drum No. 2 Loadbar, 4PS, Drum No. 3, 15 Ton Capacity Loadbar, 4PS, Drum No. 4, 15 Ton Capacity Loadbar, 4PS, Drum No. 3, 20 Ton Capacity Loadbar, 4PS, Drum No. 4, 20 Ton Capacity Loadbar, 4PS, Drum No. 5 Loadbar, 4PS, Drum No. 6	1
2	70185	Pin, 2PS, Drum Nos. 1 & 2 Pin, 2PD, Drum No. 2 Pin, 4PS, Drum Nos. 3 & 4, 15 Ton	2
2	70164	Pin, 4PS, Drum Nos. 3 & 4, 20 Ton Pin, 4PS, Drum Nos. 5 & 6	1
3	PA3796	Cotter Pin	(a)

No Recommended Spare Parts

NOTE: (a) Quantity of 4 required when 2 pins are used, and quantity of 2 required when 1 pin is used.

PARTS LIST - PRODUCT SERIES 35

HAND-GEARED TROLLEY DRIVE

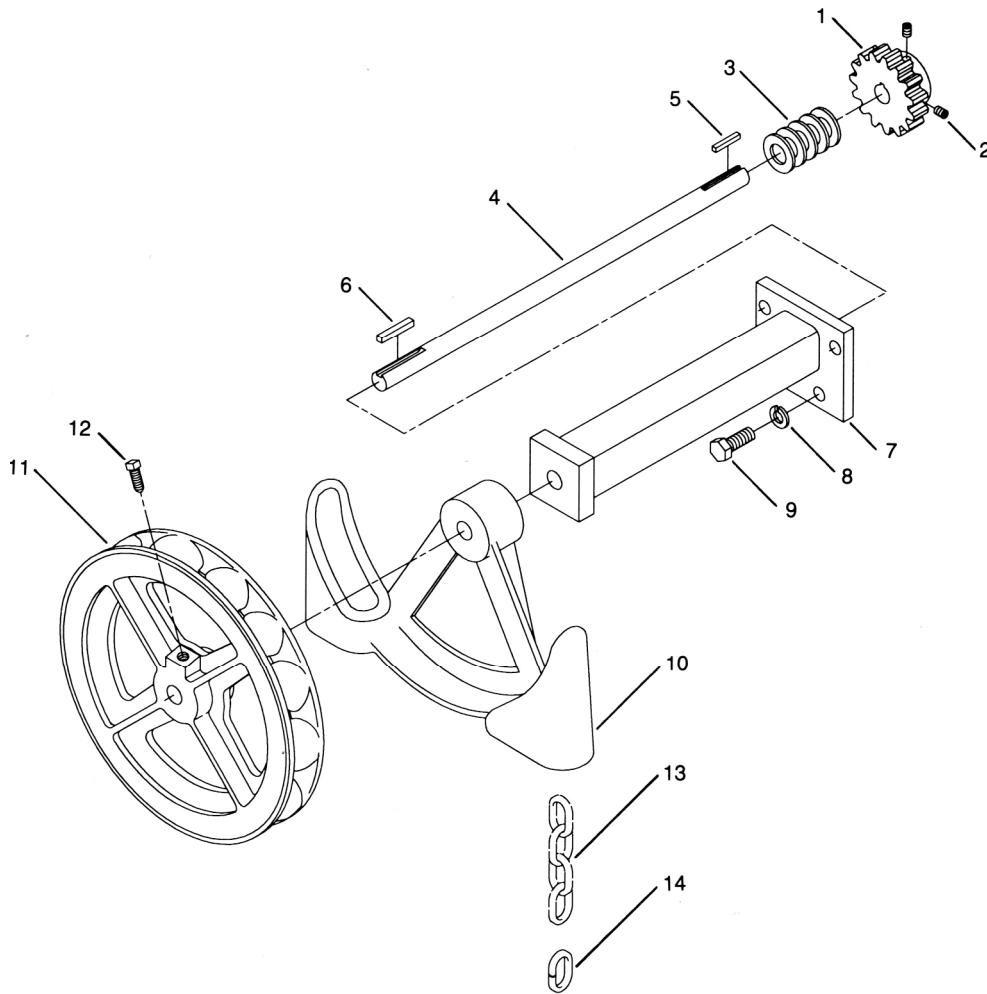

HAND-GEARED TROLLEY DRIVE PARTS

ITEM NO.	PART NUMBER	DESCRIPTION	QTY
1	69788	Pinion 15T	1
2	12-5-4	Set Screw 5/16-18x1/4	2
3	15-12-1C	Washer	5
4	69798-03	Shaft	1
5	52674	Key 3/16 Sq.x1-1/4	1
6	PA6956	Key 1/4 Sq.x1-5/8	1
7	69803-03	Bearing	1

ITEM NO.	PART NUMBER	DESCRIPTION	QTY
8	17-8C	Lockwasher 1/2	4
9	35-8-20C	Bolt 1/2-13x1-1/4	4
10	B2143-1	Handchain Guide	1
11	B464-4	Handwheel	1
12	14-6-16	Set Screw	1
13	(a)	Handchain	1
14	(a)	Open Link	1

No Recommended Spare Parts

NOTES:

- (a) When ordering handchain, order Part Number (see below) and specify length.
- (b) Federal Specification QQ-Z-325, Type I, Class 3.
- (c) Federal Specification QQ-Z-325, Type I, Class 2.

TYPE OF TROLLEY	CHAIN MATERIAL	HANDCHAIN	OPEN LINK
Steel Wheels	Steel, Zinc Electro Plated (Acco/Harrington Std) (b)	48158-1	60252-01
Steel Wheels	Steel, Zinc Electro Plated (c)	48158-11	60252-11
Bronze Wheels	Aluminum	48159-1	PA3985

PARTS LIST - PRODUCT SERIES 35

MOTORIZED MONORAIL TROLLEY DRIVE

MOTORIZED MONORAIL TROLLEY DRIVE PARTS

ITEM NO.	PART NO.	DESCRIPTION	QTY.
1	69788	Pinion (15 teeth)	1
2	12-5-4	Set Screw	2
3	17-8C	Lockwasher	4
4	35-8-20C	Hex Head Bolt	4
5	(a)	Right-Angle Gear Reducer	1
6	(b)	Motor	1
Not Shown	69807	EP Moly D Grease	(c)

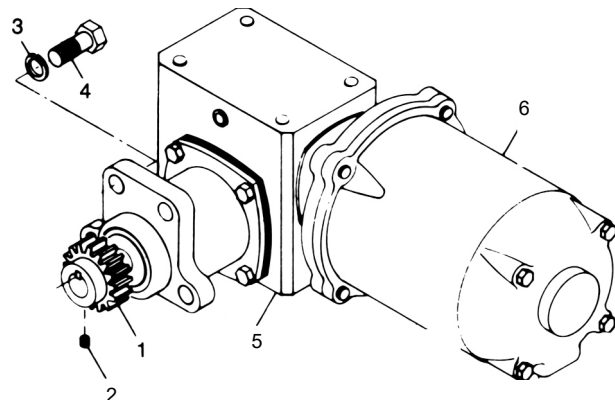

No Recommended Spare Parts

NOTES:

- (a) Select right-angle gear reducer as specified from the following:

50 FPM, Part No. 60823-42, 20:1 Reduction, (standard speed).
 100 FPM, Part No. 60823-52, 10:1 Reduction, (standard speed).
 33 FPM, Part No. 60823-72, 30:1 Reduction, (non-standard speed).
 65 FPM, Part No. 60823-82, 15:1 Reduction, (non-standard speed).
 125 FPM, Part No. 60823-92, 7.5:1 Reduction, (non-standard speed).

- (b) Trolley motor brake is optional on motorized right-angle gear reducer monorail trolley drive. Motors for trolley drive without motor brake have one shaft extension. Motors for trolley drive with motor brake have two shaft extensions. Select motor as specified from the following:

Motors for standard drive without motor brake.

Part No. 61010-01, Single speed, 1/2 hp, 1800 rpm, frame 56C, 200 volt.
 Part No. 61010-02, Single speed, 1/2 hp, 1800 rpm, frame 56C, 208/230/460 volt.
 Part No. 61010-03, Single speed, 1/2 hp, 1800 rpm, frame 56C, 575 volt.
 Part No. 61010-04, Single speed, 1 hp, 1800 rpm, frame 56C, 200 volt.
 Part No. 61010-05, Single speed, 1 hp, 1800 rpm, frame 56C, 208/230/460 volt.
 Part No. 61010-06, Single speed, 1 hp, 1800 rpm, frame 56C, 575 volt.
 Part No. 61012-01, Two speed, 1/2 hp, 1800/600 rpm, frame 56C, 200 volt.
 Part No. 61012-02, Two speed, 1/2 hp, 1800/600 rpm, frame 56C, 230 volt.
 Part No. 61012-03, Two speed, 1/2 hp, 1800/600 rpm, frame 56C, 460 volt.
 Part No. 61012-04, Two speed, 1/2 hp, 1800/600 rpm, frame 56C, 575 volt.
 Part No. 61012-05, Two speed, 1 hp, 1800/600 rpm, frame 56C, 200 volt.
 Part No. 61012-06, Two speed, 1 hp, 1800/600 rpm, frame 56C, 230 volt.
 Part No. 61012-07, Two speed, 1 hp, 1800/600 rpm, frame 56C, 460 volt.
 Part No. 61012-08, Two speed, 1 hp, 1800/600 rpm, frame 56C, 575 volt.

Motors for drive with optional motor brake.

Part No. 65818-04, Single speed, 1/2 hp, 1800 rpm, frame 56C, 200 volt.
 Part No. 65818-05, Single speed, 1/2 hp, 1800 rpm, frame 56C, 208/230/460 volt.
 Part No. 65818-06, Single speed, 1/2 hp, 1800 rpm, frame 56C, 575 volt.
 Part No. 65818-10, Single speed, 1 hp, 1800 rpm, frame 56C, 200 volt.
 Part No. 65818-11, Single speed, 1 hp, 1800 rpm, frame 56C, 208/230/460 volt.
 Part No. 65818-12, Single speed, 1 hp, 1800 rpm, frame 56C, 575 volt.
 Part No. 65819-01, Two speed, 1/2 hp, 1800/600 rpm, frame 56C, 200 volt.
 Part No. 65819-02, Two speed, 1/2 hp, 1800/600 rpm, frame 56C, 230 volt.
 Part No. 65819-03, Two speed, 1/2 hp, 1800/600 rpm, frame 56C, 460 volt.
 Part No. 65819-04, Two speed, 1/2 hp, 1800/600 rpm, frame 56C, 575 volt.
 Part No. 65819-09, Two speed, 1 hp, 1800/600 rpm, frame 56C, 200 volt.
 Part No. 65819-10, Two speed, 1 hp, 1800/600 rpm, frame 56C, 230 volt.
 Part No. 65819-11, Two speed, 1 hp, 1800/600 rpm, frame 56C, 460 volt.
 Part No. 65819-12, Two speed, 1 hp, 1800/600 rpm, frame 56C, 575 volt.

For other specified special motors, refer to additional information pages supplied with manual.

- (c) Exposed gears and pinions on trolleys are shipped from the factory without lubricant. Lyondell® EP Moly D Grease, packaged in a 4-ounce bottle container, is furnished with all hoists that have trolleys specified. Refer to LUBRICATION section of Manual 69833: Installation, Operation, and Maintenance Manual for WRIGHT® WORK-RATED® Wire Rope Electric Hoists. Additional containers of Lyondell® EP Moly D Grease, packaged in a 4-ounce bottle, can be obtained by ordering Acco/Harrington part no. 69807.

PARTS LIST - PRODUCT SERIES 35

MOTORIZED MONORAIL TROLLEY RIGHT-ANGLE GEAR REDUCER

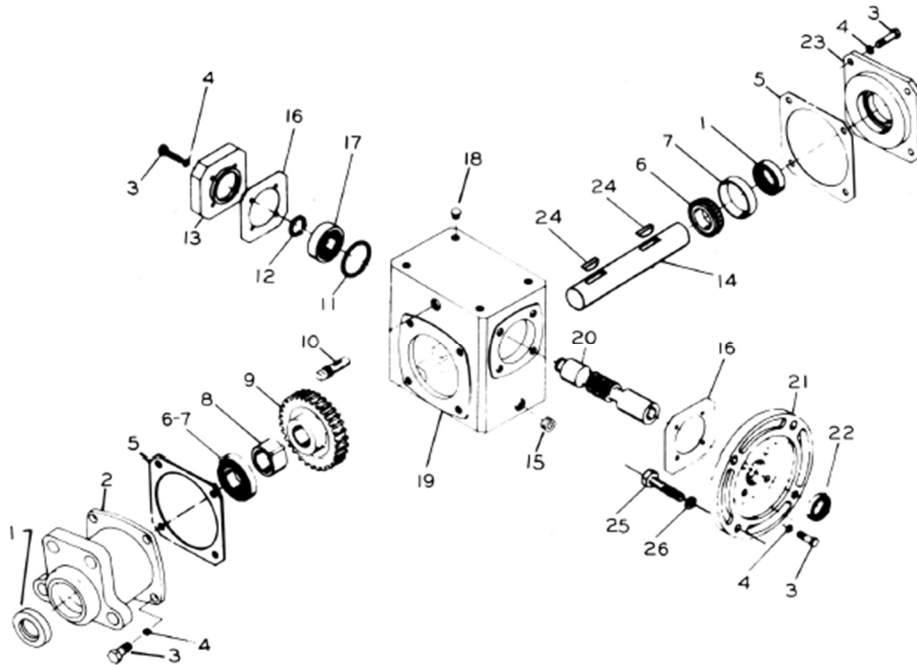

RIGHT-ANGLE GEAR REDUCER PARTS

ITEM NO.	PART NUMBER	DESCRIPTION	QTY/ ASSY
1*	V93005	Oil Seal	2
2	V28256C	Adapter	1
3	35-4-14	Hex Head Cap Screw, 1/4-20x7/8	16
4	17-4C	Lock Washer, 1/4	16
	V49020A	Output Cover Gasket	2
5	V49021A	Gasket Cover .010 Vellumoid	AR
	V49022A	Gasket Cover .015 Vellumoid	AR
6	V40831	Output Bearing (Cone)	2
7	V40832	Output Bearing (Cup)	2
8	V41526A	Gear Spacer	1
9	V25014B	Worm Gear 5:1	1
	V25015B	Worm Gear 10:1	1
	V25017B	Worm Gear 20:1	1
10	V41752	Vent Plug	1
11	V40260	Retaining Ring (Housing) Internal	1
12	V41050	Retaining Ring (Shaft) External	1

ITEM NO.	PART NUMBER	DESCRIPTION	QTY/ ASSY
13	V48002B	Input Cover (Bearing)	1
14	V36732B	Output Shaft	1
15	V40411	Pipe Plug	6
	V49017A	Input Cover Gasket	2
16	V49018A	Gasket Cover .010 Vellumoid	AR
	V49019A	Gasket Cover .015 Vellumoid	AR
17	V40257	Input Bearing	1
18	V40813	Protective Plug	8
19	V29000D	Gear Housing	1
NS	V95102A	Splash Guard	1
	V12034B	Quill Input Shaft 5:1	1
20	V12035B	Quill Input Shaft 10:1	1
	V12037B	Quill Input Shaft 20:1	1
21	V28046D	Quill Motor Flange	1
22*	V40770	Oil Seal	1
23	V48049B	Output Cover (Bearing)	1
24	PA1357	Woodruff Key	2
25	35-6-16	Hex Head Cap Screw, 3/8-16x1	4
26	17-6C	Lock Washer, 3/8	4

*Recommended Spare Parts

NOTE:

For worm gear (Item No. 9) and quill input shaft (Item No. 20) for 7.5:1, 15:1 and 30:1 ratios, contact Acco/Harrington or the distributor of the hoist.

PARTS LIST - PRODUCT SERIES 35

MOTORIZED TOP-RUNNING TROLLEY DRIVE ASSEMBLY

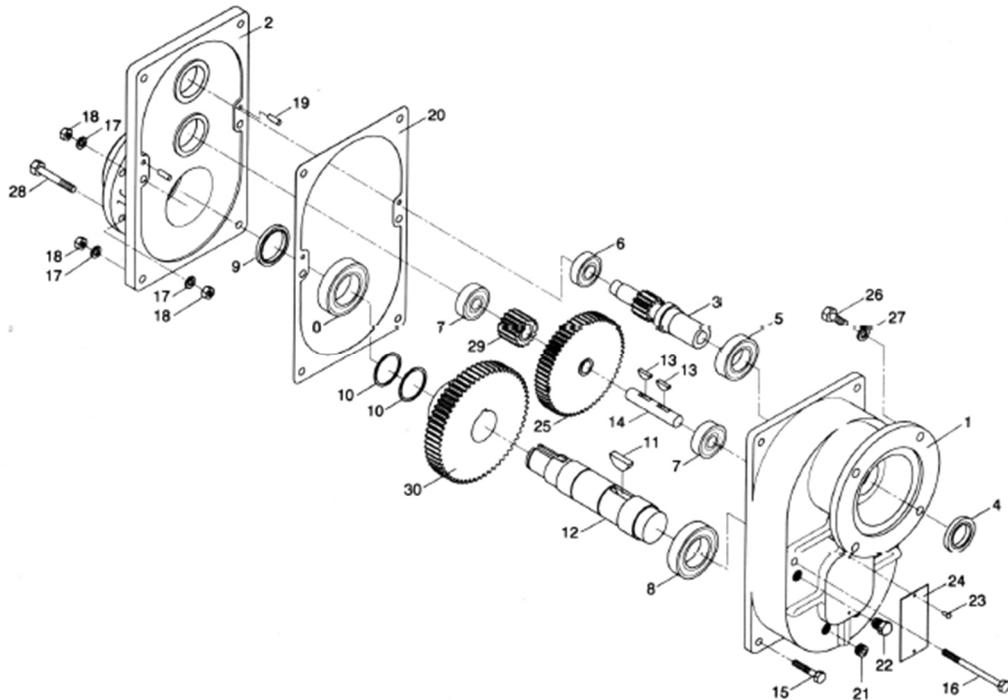

MOTORIZED TOP-RUNNING TROLLEY DRIVE PARTS

ITEM NO.	PART NUMBER	DESCRIPTION	QTY/ ASSY
1	69407	Input Reducer Housing	1
2	69409	Output Reducer Housing	1
3	69415	Motor Pinion Shaft	1
4*	PA6662	Oil Seal	1
5	PA6655	Bearing	1
6	PA2464	Bearing	1
7	PA1129	Bearing	2
8	PA1569	Bearing	2
9*	PA1993	Oil Seal	1
10	PA7349	Retaining Ring	2
11	PA1416	Woodruff Key	1
12	69417	Output Shaft	1
13	PA1175	Woodruff Key	2
14	69416	Intermediate Shaft	1
15	35-5-24	Bolt 5/16-18 x 1-1/2	4
16	35-5-60	Bolt 5/16-18 x 3-3/4	2
17	17-5C	Lockwasher 5/16	10

ITEM NO.	PART NUMBER	DESCRIPTION	QTY/ ASSY
18	22-5C	Hex Nut 5/16-18	10
19	PA5439	Dowel Pin	2
20*	69405	Gasket	1
21	PA786	Hex Socket Pipe Plug	3
22	PA7350	Breather Plug	1
23	PA897	Drive Pin	2
24	69106	Serial Plate	1
25	69414	Intermediate Gear	1
26	35-6-16	Motor Mounting Bolt 3/8-16 x 1	4
27	17-6C	Lockwasher 3/8	4
28	35-5-24	Reducer Mtg. Bolt 5/16-18 x 1-1/2	4
	35-5-36	Reducer Mtg. Bolt 5/16-18 x 2-1/4	

TROLLEY SPEED	40-50 FPM	65-75 FPM	95-110 FPM
GEAR BOX RATIO	23:1	15:1	10:1
ITEM 29 PART NO.	69411	69412	69413
ITEM 30 PART NO.	B4073	B4074	B4075

*Recommended Spare Parts

NOTES:

- Pinion assembled on top-running trolley drive output shaft that meshes with top-running trolley geared wheel is not shown. Parts required are one each of: 51291, Pinion; 68290, key, and PA3269, Retaining Ring.
- Trolley motor brake is standard on motorized top-running trolley drive. Motors for trolley drive with motor brake have two shaft extensions. Select motor with two shaft extensions as specified on page 31.
- Exposed gears and pinions on trolleys are shipped from the factory without lubricant. Lyondell® EP Moly D Grease, packaged in a 4-ounce bottle container, is furnished with all hoists that have trolleys specified. Refer to LUBRICATION section of Manual 69833: Installation, Operation, and Maintenance Manual for WRIGHT® WORK-RATED® THE NEW CENTURY SERIES® Wire Rope Electric Hoists. Additional containers of Lyondell® EP Moly D Grease, packaged in a 4-ounce bottle, can be obtained by ordering Acco/Harrington part no. 69807.

PARTS LIST - PRODUCT SERIES 35

TROLLEY MOTOR BRAKE ASSEMBLY

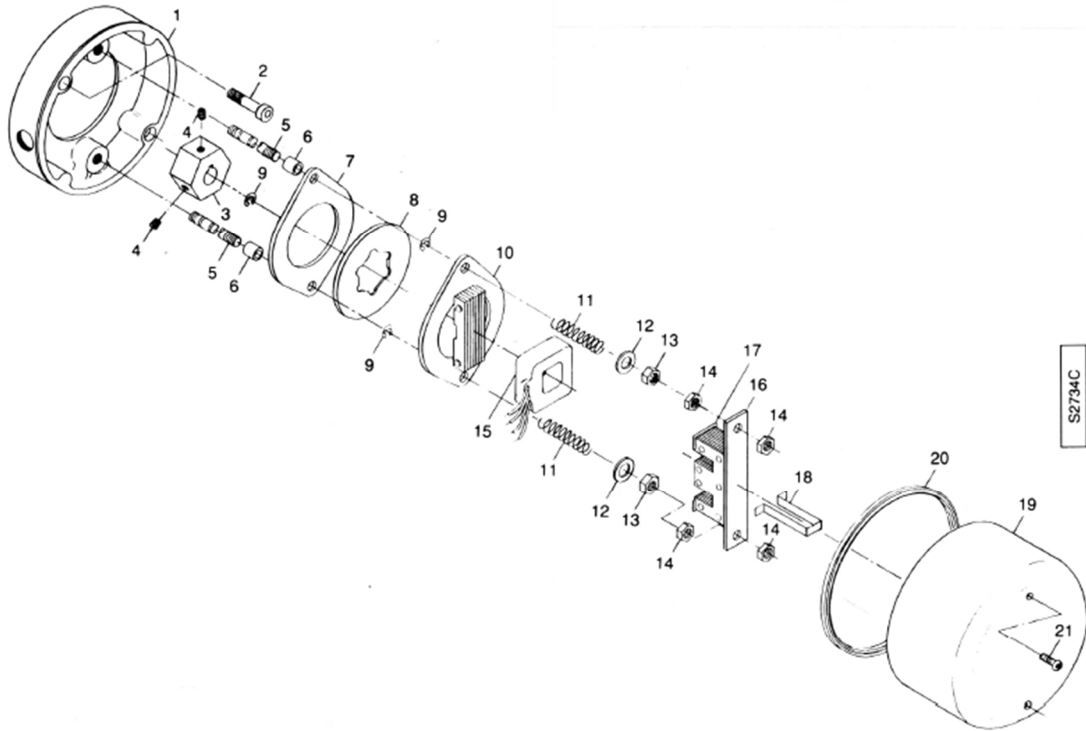

TROLLEY MOTOR BRAKE PARTS

ITEM NO.	PART NUMBER	DESCRIPTION	QTY/ ASSY
1	65653	Adapter	1
2	1-6-24	Bolt, 3/8-16 x 1-1/2 lg	2
3	65654	Hub	1
4	12-4-6	Set Screw	2
5	65655	Stud	2
6	61459	Spacer	2
7	39794	Brake Plate	1
8*	39649	Brake Lining	1
9	PA5623	Retaining Ring	2
10	39781	Pressure Unit	1
11	PA5823	Spring	2
12	15-6-1	Flat Washer	2

ITEM NO.	PART NUMBER	DESCRIPTION	QTY/ ASSY
13	PA2377	Locknut	2
14	24-6	Jam Nut, 3/8	4
15*	39783-2 39783-3 39783-6	Coil 575 VAC 230/460 VAC 208 VAC	1
16	39780	Magnet Unit	1
17	39784	Shading Coil (a)	2
18	39877	Coil Strap	1
19	69161	Brake Cover	1
20	PA7110	Gasket	1.77ft
21*	PA7323	Screw, LOC-WEL, #10-24 (b)	2

*Recommended Spare Parts

(a) Shading Coil is furnished with Magnet Unit, but also available as a spare.

(b) Screw with self-locking feature must be utilized. Substitutes are not permissible.

PARTS LIST - PRODUCT SERIES 35

DECK MOUNTED FRAME

DECK MOUNTED FRAME PARTS

ITEM NO.	DESCRIPTION	QUANTITY	PART NO.
1	End Plate, Deck Mounted Gear End	1	70427
2	End Plate, Deck Mounted Control End	1	70428
3	Frame, 2-Part Single, Drum 1 Frame, 2-Part Single, Drum 2 Frame, 2-Part Single, Drum 3 Frame, 2-Part Single, Drum 4 Frame, 2-Part Single, Drum 5 Frame, 2-Part Single, Drum 6	1	70382-01 70382-02 70425-03 70425-04 70425-05 70425-06
3	Frame, 2-Part Double, Drum 2 Frame, 2-Part Double, Drum 3 Frame, 2-Part Double, Drum 4 Frame, 2-Part Double, Drum 5 Frame, 2-Part Double, Drum 6	1	70397 70393-03 70393-04 70416-05 70416-06
3	Frame, 4-Part Single, Drum 3 Frame, 4-Part Single, Drum 4 Frame, 4-Part Single, Drum 5 Frame, 4-Part Single, Drum 6	1	70319-03 70319-04 70426-05 70426-06
3	Frame, 4-Part Double, Drum 4 Frame, 4-Part Double, Drum 5 Frame, 4-Part Double, Drum 6	1	70422-04 70422-05 70423

Note:

For part numbers of other parts shown, refer to page 9 for 2PS reeving, page 10 for 4PS reeving, page 11 for 2PD reeving, or page 12 for 4PD reeving.

No Recommended Spare Parts

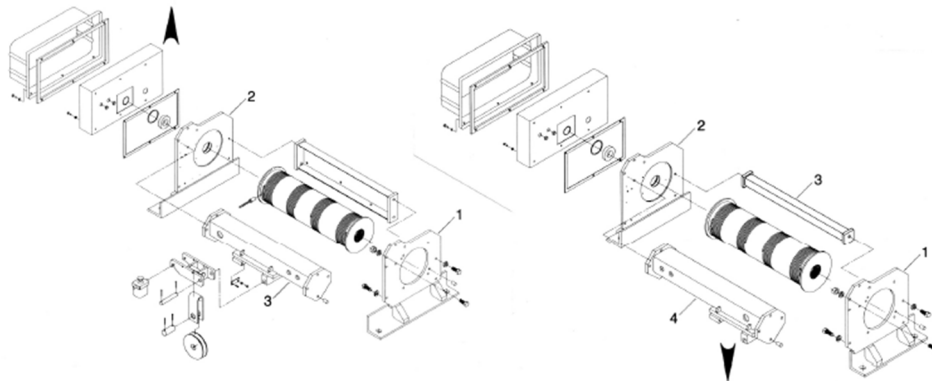

WINCH UNIT FRAME

WINCH UNIT FRAME PARTS

ITEM NO.	DESCRIPTION	QUANTITY	PART NO.
1	End Plate, Winch Gear End	1	70429
2	End Plate, Winch Control End	1	70430
3	Side Frame, Winch	1	(a)
4	Frame, Winch	1	(a)

No Recommended Spare Parts

Note:

For part numbers of other parts shown, refer to page 9 for 2PS reeving, page 10 for 4PS reeving, page 11 for 2PD reeving, or page 12 for 4PD reeving.

(a) Winch side frame part number 70210-XX and winch frame part number 70432-XX are available in various lengths. Contact Acco/Harrington or the distributor of the hoist with hoist product number and/or hoist serial number.

PARTS LIST - PRODUCT SERIES 35

TOP-RUNNING TROLLEY

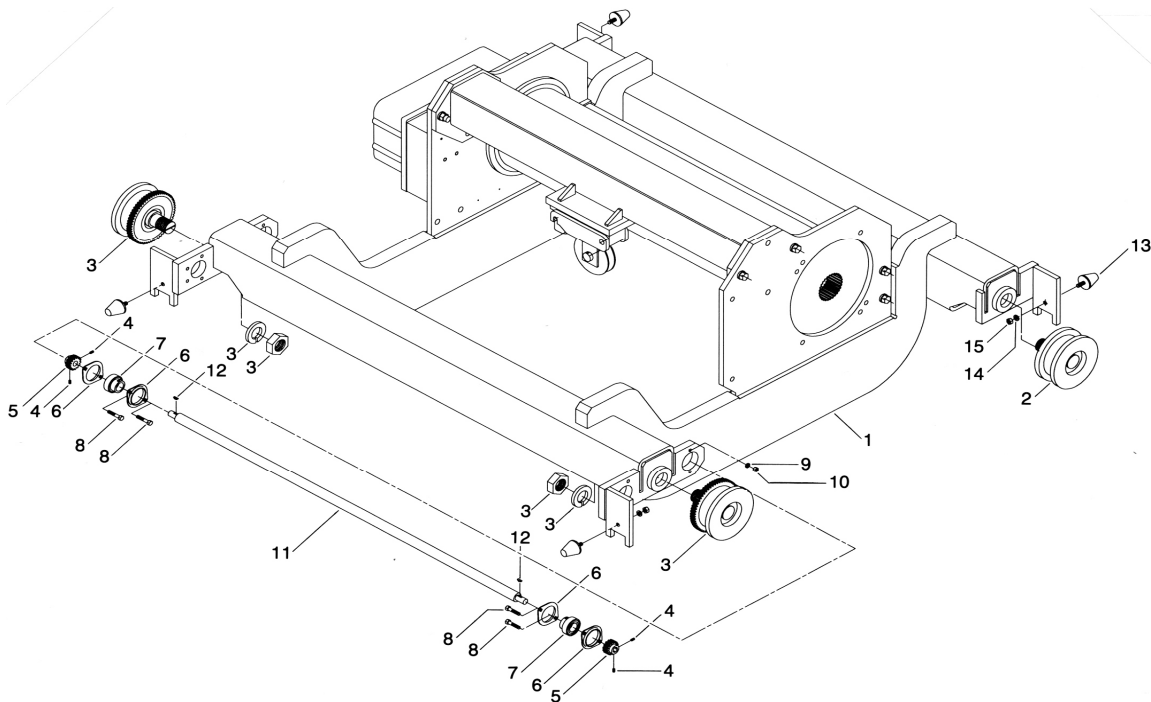

TOP-RUNNING TROLLEY FRAME PARTS

ITEM NO.	DESCRIPTION	QUANTITY	PART NO.
1	Trolley Frame, Trolley End Beams, End Plates, Gear End and Control End	1	(a)
2	Plain Wheel Assembly	2	70237-02
3	Geared Wheel Assembly	2	70237-01
4	Set Screw	4	12-4-4C
5	Pinion	2	62214
6	Bearing Flange	4	PA6154
7	Bearing	2	PA6153
8	Hex Head Bolt	4	35-6-28
9	Lockwasher	4	17-6C
10	Nut	4	22-6
11	Shaft, Wheel Gage 60"	1	69335-03
11	Shaft, Wheel Gage 78"	1	69335-04
11	Shaft, Wheel Gage 96"	1	69335-05
12	Woodruff Key	2	PA1357
13	Bumper (Optional)	4	65226
14	Lockwasher (Optional)	4	17-7
15	Nut (Optional)	4	22-7

Notes:

For part numbers of other suspension frame parts, refer to page 10 for 4PS reeving, page 11 for 2PD reeving, or page 12 for 4PD reeving.

(a) Trolley side frame, trolley end beams, and hoist end plates are a single welded unit. Contact Acco/Harrington or the distributor of the hoist with hoist product number and/or hoist serial number; and wheel gage of trolley.

(b) When dual motorized trolley drives are used, item numbers 4, 5, 6, 7, 8, 9, 10, 11 and 12 are not used.

No Recommended Spare Parts

PARTS LIST - PRODUCT SERIES 35

LOADBAR ASSEMBLY – FOR SWIVELING TROLLEYS

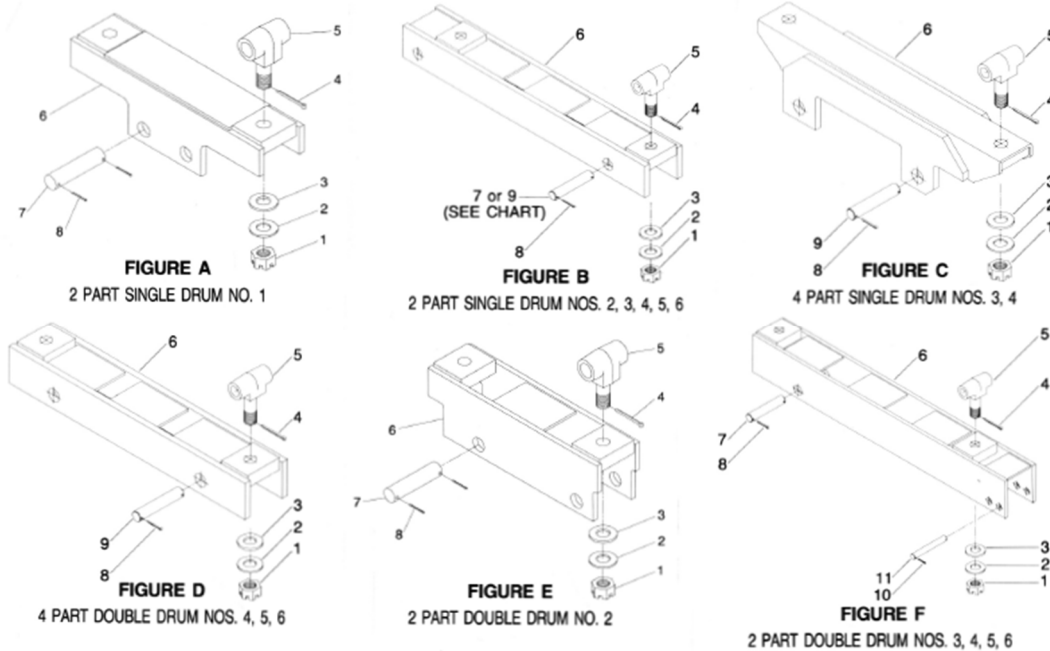

REFER TO FIGURE		A, B (DRUM 2), E		B (DRUMS 3, 4, 5, 6), C, D		F	
ITEM. NO.	DESCRIPTION	PART NUMBER	QTY	PART NUMBER	QTY	PART NUMBER	QTY
1	Hex Slotted Nut	26-28	2	26-28	2	26-28	2
2	Thrust Washer	A4421	2	A4421	2	A4421	2
3	Thrust Bearing	A4420	2	A4420	2	A4420	2
4	Cotter Pin	PA1484	2	PA1484	2	PA1484	2
5	Suspension Stud	63161	2	63161	2	63161	2
6	Loadbar	(a) (b)	1	(a) (b)	1	(a) (b)	1
7	Pin	63029-05	2	-	-	63029-05	1
8	Cotter Pin	PA1484	4	PA1484	4	PA1484	2
9	Pin	-	-	63029-01	2	-	-
10	Cotter Pin	-	-	-	-	PA1771	4
11	Pin	-	-	-	-	63295-03	2

No Recommended Spare Parts

NOTES:

For trolley parts, refer to pages 26, 27, and 28.

(a) Loadbar part numbers for:

FIGURE A	FIGURE B	FIGURE C	FIGURED	FIGURE E	FIGURE F
70438-01	70439-02	70444-03	70449-04	70445-02	70286-13
	70440-03	70444-04	70449-05		70286-14
	70440-04		70449-06		70286-15
	70440-05				70286-16
	70440-06				

(b) Dash number (-03, -04, etc.) indicates corresponding hoist drum length.

Example: For Figure C: 70444-03 for Drum No. 3, 70444-04 for Drum No. 4, etc.

For Figure F: 70286-13 for Drum No. 3, 70286-14 for Drum No. 4, etc.

PARTS LIST - PRODUCT SERIES 35

OPTIONAL ELECTRICAL CONTROL ENCLOSURE

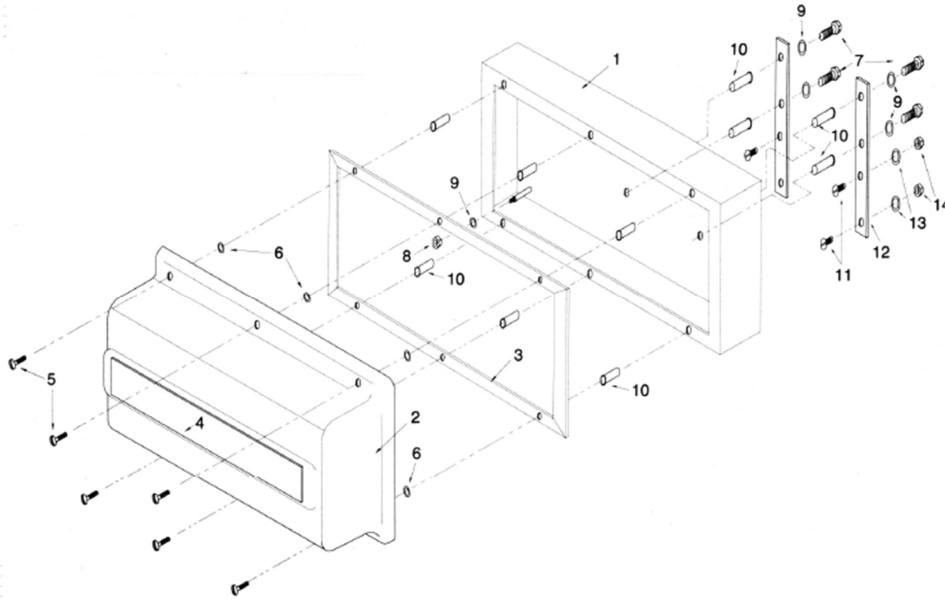

REPLACEMENT PARTS

ITEM NO.	PART NO.	DESCRIPTION	QUANTITY BY ENCLOSURE SIZE		
			11" x 21"	15" x 21"	21" x 21"
1	69829-1	Enclosure, 11" x 21"	1	N/A	N/A
	69828-1	Enclosure, 15" x 21"	N/A	1	N/A
	69875-1	Enclosure, 21" x 21"	N/A	N/A	1
2	52823	Cover, 11" x 21"	1	N/A	N/A
	52826	Cover, 15" x 21"	N/A	1	N/A
	54268	Cover, 21" x 21"	N/A	N/A	1
3	58531	Gasket, 11" x 21"	1	N/A	N/A
	55204	Gasket, 15" x 21"	N/A	1	N/A
	55206	Gasket, 21" x 21"	N/A	N/A	1
4	55224-2	Label	1	1	1
5	58597	Screw, Captive	6	6	8
6	PA6634	Ring, Retaining	6	6	8
7	35-4-12	Hex Head Bolt	4	4	4
8	22-4C	Hex Nut	4	4	4
9	17-4C	Lockwasher	8	8	8
10	PA7343	Nut Insert, Closed End	10	10	12
11	5-6-20	Flathead Screw	4	4	4
12	69808	Enclosure Mounting Strap	2	2	2
13	17-6C	Lockwasher	4	4	4
14	22-6	Hex Nut	4	4	4

GENERAL CONDITIONS OF WARRANTY

Buyer must notify HHI in writing within sixty (60) days of discovery of any alleged defect, if within the applicable warranty period.

All products sold by HHI are warranted to be free from defects in material and workmanship from date of shipment by HHI for the following periods:

- 1 year – Air Powered Hoists, SNER, TNER, NER030L, and ED Electric Chain Hoists, Powered Trolleys, Powered Tiger Track Jibs and Gantries, Crane Components, Below the Hook Devices, Spare / Replacement Parts**
- 2 years – Manual Hoists & Trolleys, Beam Clamps, ACCO Wire Rope Hoists, ACCOLIFT Electric Chain Hoists, Louden and Trambeam Patented Track**
- 3 years – (N)ER2 Hoists, EQ/SEQ Hoists, (T)EM/(T)SEM hoists, and RY Hoists**
- 5 years – Manual Tiger Track Jibs and Gantries, Hoist Motor Brakes for EQ/SEQ, (T)EM/(T)SEM, and RY**
- 10 years – (N)ER2 Brake, TNER Hoist Motor Brake, Tiger Track Workstation Cranes and Monorails**

The product must be used in accordance with manufacturer's recommendations and must not have been subject to abuse, lack of maintenance, misuse, negligence, or unauthorized repairs or alterations.

Should any defect in material or workmanship occur during the above time period in any product, as determined by HHI's inspection of the product, HHI agrees, at its discretion, either to replace (not including installation) or repair the part or product free of charge. For customers in the U.S., delivery shall be made F.O.B. HHI's place of business. For international customers, delivery shall be made FCA HHI place of business, United States of America (Incoterms 2010).

No warranty claim will be honored without a valid proof of purchase. Customers must obtain a Return Goods Authorization as directed by HHI or its published repair center prior to shipping product for warranty evaluation. An explanation of the complaint must accompany the product. Product must be returned freight prepaid. Upon repair, the product will be covered for the remainder of the original warranty period. Replacement parts installed after the original warranty period will only be eligible for replacement (not including installation) for a period of one year from the installation date. If it is determined there is no defect, or that the defect resulted from causes not within the scope of HHI's warranty, the customer will be responsible for the costs of returning the product.

HHI DISCLAIMS ANY AND ALL OTHER WARRANTIES OF ANY KIND, EXPRESSED OR IMPLIED, AS TO THE PRODUCT'S MERCHANTABILITY OR FITNESS FOR A PARTICULAR PURPOSE. HHI WILL NOT BE LIABLE FOR DEATH, INJURIES TO PERSONS OR PROPERTY OR FOR INCIDENTAL, CONTINGENT, SPECIAL OR CONSEQUENTIAL DAMAGES, LOSS OR EXPENSE ARISING IN CONNECTION WITH THE USE OR MISUSE OF THE PRODUCTS, REGARDLESS OF WHETHER THE DAMAGE, LOSS OR EXPENSE RESULTS FROM ANY ACT OR FAILURE TO ACT BY HHI, WHETHER NEGLIGENT OR WILLFUL, OR FROM ANY OTHER CAUSE.



Harrington Hoists, Inc.
401 West End Avenue
Manheim, PA 17545

www.harringtonhoists.com

Toll Free: 800-233-3010
Phone: 717-665-2000
Fax: 717-665-2861

© HARRINGTON HOISTS, INC.
ALL RIGHTS RESERVED

ACC69837-20