

Acco[®] WRIGHT[®]

WORK-RATED[®]
THE NEW CENTURY SERIES[®]

wire rope electric hoists

installation
operation and
maintenance
manual

SERIAL NUMBER

⚠ WARNING

This equipment should not be installed, operated or maintained by any person who has not read all the contents of these instructions. Failure to read and comply with these instructions or any one of the limitations noted herein can result in serious bodily injury or death, and/or property damage.

There are no other warranties which extend beyond the description on the Order Acknowledgment and as it may apply to the specifications provided in this publication. THE IMPLIED WARRANTIES OF MERCHANTABILITY AND FITNESS FOR A PARTICULAR PURPOSE ARE EXCLUDED. Acco shall in no event be liable for any special, direct, indirect, incidental or consequential damages to anyone beyond the cost of replacement of the goods sold hereby.

TABLE OF CONTENTS

<u>SUBJECT</u>	<u>PAGE</u>
IMPORTANT INFORMATION AND WARNINGS	3
INSTALLATION	5
OPERATION	14
MOTOR OVERLOAD FEATURES	18
MAINTENANCE AND INSPECTION PROCEDURES	20
INSPECTION	22
TEST	26
MAINTENANCE AND REPAIR	31
LUBRICATION	32
HOOKS	38
LIMIT SWITCHES	42
MECHANICAL LOAD BRAKE	52
HOIST MOTOR BRAKE	56
ELECTRICAL COMPONENTS	67
ACCELERATION CONTROL MODULE V	72
OVERLOAD CUTOFF DEVICE	74
WIRE ROPE	76
UNIVERSAL JOINTS	83
TROLLEYS	87
TROUBLE SHOOTING	90
TYPICAL WIRING DIAGRAM	94
PARTS IDENTIFICATION PAGES	Refer to Parts Manual

IMPORTANT INFORMATION AND WARNINGS

SAFETY ALERT SYMBOL

The Safety Alert Symbol is used in this manual to indicate hazards and to alert the reader to information that should be known, understood, and followed in order to avoid DEATH or SERIOUS INJURY.

Read and understand this manual before using the hoist.

Important issues to remember during operation are provided at the hoist control stations, at various locations on the hoist and in the manuals by DANGER, WARNING, or CAUTION instructions or placards, that alert the personnel to potential hazards, proper operation, load limitations, and more.

DANGER

Indicates an imminently hazardous situation which, if not avoided, will result in death or serious injury.

WARNING

Indicates a potentially hazardous situation which, if not avoided, could result in death or serious injury.

CAUTION

Indicates a potentially hazardous situation which, if not avoided, may result in minor or moderate injury. It may also be used to alert against unsafe practices.

CAUTION

These general instructions deal with the normal installation, operation, and maintenance situations encountered with the equipment described herein. The instructions should not be interpreted to anticipate every possible contingency or to anticipate the final system, crane, or configuration that uses this equipment.

This manual includes instructions and parts information for a variety of hoist types. Therefore, all instructions and parts information may not apply to any one type or size of specific hoist. Disregard those portions of the instructions that do not apply.

Record hoist serial number on the front cover of this manual for identification and future reference to avoid referring to the wrong manual for information or instructions on installation, operation, inspection, maintenance, or parts.

Use only Wright® authorized replacement parts in the service and maintenance of this hoist.

WARNING

Equipment described herein is not designed for and should not be used for lifting, supporting, or transporting humans.

Equipment described herein should not be used in conjunction with other equipment unless necessary and/or required safety devices applicable to the system, crane, or application are installed by the system designer, system manufacturer, crane manufacturer, installer, or user.

Modifications to upgrade, rerate, or otherwise alter this equipment shall be authorized only by the original equipment manufacturer or qualified professional engineer.

Equipment described herein may be used in the design and manufacture of cranes or monorails. Additional equipment or devices may be required for the crane or monorail to comply with applicable crane design and safety standards. The crane designer, crane manufacturer, or user is responsible to furnish these additional items for compliance. Refer to ASME B30.17, Safety Standard for Cranes and Monorails (with Underhung Trolley or Bridge); and ASME B30.2 Safety Standard for Top-Running Double-Girder Cranes. If a below-the-hook lifting device or sling is used with a hoist, refer to ASME B30.9, Safety Standard for Slings, or ASME B30.20, Safety Standard for Below-the-Hook Lifting Devices.

Hoists and cranes, used to handle hot molten material may require additional equipment or devices. Refer to ANSI Z241.2, Safety Requirements for Melting and Pouring of Metals in the Metalcasting Industry.

Electrical equipment described herein is designed and built in compliance with Acco Material Handling Solutions interpretation of ANSI/NFPA 70, National Electrical Code. The system designer, system manufacturer, crane designer, crane manufacturer, installer, or user is responsible to assure that the installation and associated wiring of these electrical components is in compliance with ANSI/NFPA 70, and all applicable Federal, State, and Local Codes.

Failure to read and comply with any of the limitations noted herein can result in serious bodily injury or death, and/or property damage.

IMPORTANT INFORMATION AND WARNINGS

DANGER

HAZARDOUS VOLTAGES ARE PRESENT IN THE CONTROL ENCLOSURE, OTHER ELECTRICAL COMPONENTS, AND CONNECTIONS BETWEEN THESE COMPONENTS.

Before performing ANY mechanical or electrical maintenance on the equipment, de-energize (disconnect) the main switch supplying power to the equipment; and lock and tag the main switch in the de-energized position. Refer to ANSI Z244.1, Personnel Protection — Lockout/Tagout of Energy Sources.

Do not operate the equipment without control enclosure cover or covers in place.

Only trained and competent personnel should inspect and repair this equipment.

NOTICE

It is the responsibility of the owner/user to install, inspect, test, maintain, and operate a hoist in accordance with ASME B30.16, Safety Standard for Overhead Hoists, OSHA Regulations, and ANSI/NFPA 70, National Electrical Code. If the hoist is installed as part of a total lifting system, such as an overhead crane or monorail, it is also the responsibility of the owner/user to comply with the applicable ASME B30 volume that addresses that type of equipment.

It is the responsibility of the owner/user to have all personnel that will install, inspect, test, maintain, and operate a hoist read the contents of this manual and applicable portions of ASME B30.16, Safety Standard for Overhead Hoists, OSHA Regulations, and ANSI/NFPA 70, National Electrical Code. If the hoist is installed as part of a total lifting system, such as an overhead crane, the applicable ASME B30 volume that addresses that type of equipment must also be read by all personnel.

Any ANSI Standards referenced in this manual may be obtained from the American National Standards Institute, 1430 Broadway, New York, New York 10018.

This manual contains information for safe operation of an overhead hoist. Taking precedence over any specific rule, however, is the most important rule of all "USE COMMON SENSE." Operation of an overhead hoist involves more than operating the controls. The operator must consider and anticipate the motions and actions that will occur as a result of operating the controls.

If the hoist owner/user requires additional information, or if any information in the manual is not clear, contact Acco Material Handling Solutions, York, Pennsylvania or the distributor of the hoist. Do not install, inspect, test, maintain, or operate the hoist unless this information is fully understood.

When contacting Acco Material Handling Solutions or the distributor of the hoist, always make reference to the serial number of the hoist.

A regular schedule of inspection of the hoist in accordance with the requirements of the ASME B30.16 should be established and records maintained.

WARNING

Before installing, removing, inspecting, or performing any maintenance on a hoist, the main switch shall be de-energized. Lock and tag the main switch in the de-energized position in accordance with ANSI Z244.1. Follow other maintenance procedures outlined in this manual and applicable ASME B30 volumes.

Additional WARNINGS are listed in various portions of this manual. Personnel shall read and follow these WARNINGS. Failure to read and comply with these WARNINGS as well as other instructions or any limitations noted in this manual and applicable ASME B30 volumes could result in serious bodily injury or death, and/or property damage.

INSTALLATION

PRIOR TO INSTALLING HOIST:

1. Read and observe the instructions and warnings contained in this manual. Read and observe any instructions and warning tags attached to the hoist.
2. Check for any damage to the hoist during shipment. If any damage has occurred, place a claim with the carrier. DO NOT install a damaged hoist.
3. Check wire rope for damage and spooling on drum. Be sure rope is properly seated in drum grooves and sheaves.
4. Locate any vent plugs attached to or included with the hoist and trolley. Remove solid shipping plug or plugs and replace with a vent plug.
5. Check lubricant in gear housing. Oil level should be even with oil level plug in housing. If additional gear housing lubricant is required, refer to the LUBRICATION section of this manual. Lubricate any exposed gears and pinions on the trolley with the open gear lubricant supplied with the trolley.
6. Remove drain plug, if provided, from the lowest position of the motor. This will allow moisture to escape so that it does not condense and accumulate inside the motor housing.
7. Check that the crane, monorail, or other supporting structure where the hoist will be installed has a load rating capable to handle loads equal to the rated load capacity of the hoist.
8. If hoist has a trolley, check that the crane bridge beam or monorail beam is level, straight, and clean. Check that trolley stops are installed, or install trolley stops, at the open end or ends of the beam to prevent the trolley from traveling off the beam. Trolley stops that engage trolley wheels are not recommended. Check that trolley stops will prevent overhanging parts of the hoist and trolley from interfering with other equipment beyond the ends of the beam or monorail.
9. If hoist is to be installed on an existing crane, the crane should be run to a location where it will cause the least interference with other cranes and operations in the area; and all controllers placed in the off position.
10. Warning signs and barriers shall be utilized on the floor beneath the crane or area where the hoist will be installed.

DANGER

11. The main switch (disconnect) supplying power to the crane, monorail, or other piece of equipment where the hoist is to be installed, shall be de-energized. Lock and tag the main switch in the de-energized position in accordance with ANSI Z244.1.
12. If the hoist is to be installed on an existing crane, and the crane runway remains energized because of other cranes operating on the same runway; stops or a signal person(s), located full-time at a visual vantage point for observing the approach of an active crane(s), shall be provided to prohibit contact by the active crane(s) with the idle crane.
13. If personnel will be required to work on the runway during installation, a guard or barrier shall be installed between adjacent runways for the length of the established work area to prevent contact between persons performing installation and a crane on the adjacent runway.
14. If personnel are required to work at elevations in excess of 6 feet above floor or ground level, a fall prevention policy and procedure shall be developed, documented, and implemented prior to installation being started.
15. Check power supply that will be furnished to the hoist. It must be the same as shown on the hoist serial plate.
 - a. Standard hoist single-speed motors are reconnectable for 230 volt or 460 volt, three phase, 60 Hz. operation. Standard trolley single-speed motors are reconnectable for 208/230 volt or 460 volt, three-phase, 60 Hz. operation. Such motors and control will be connected at the factory for 460 volt unless otherwise specified.
 - b. All two-speed motors, 200 volt single-speed motors, and 575 volt single-speed motors are single voltage motors, and are not reconnectable.

INSTALLATION

- c. If the power supply that will be furnished to the hoist is not the same as shown on the hoist serial plate for two-speed, 200 volt single-speed, and 575 volt single-speed hoists; **DO NOT INSTALL**. Contact Acco Material Handling Solutions or the distributor of the hoist.
 - d. If reconnection of a 230/460 volt motor is required, proceed as follows:
 - (1) If hoist is connected to the main power supply, de-energize, lock, and tag the main switch (disconnect) in accordance with step 11 of "PRIOR TO INSTALLING HOIST" instructions.
 - (2) Reconnect the control circuit transformer, located inside the brake and limit switch control enclosure. Connection instructions are located on the transformer and in the ELECTRICAL COMPONENTS section of this manual.
 - (3) Reconnect the hoist motor leads inside the hoist motor junction box. Connection instructions are located in the ELECTRICAL COMPONENTS section of this manual. The hoist motor brake is powered from the control circuit transformer and does not require reconnection.
 - (4) Reconnect the trolley motor leads (and trolley motor brake leads, if so equipped) inside the trolley motor junction box. Connection instructions are located in the ELECTRICAL COMPONENTS section of this manual.
 - (5) If the hoist is equipped with optional motor circuit fuses or overload relays sized for the original connection voltage, they must be replaced with ones properly sized for the reconnected voltage.
 - (6) If the hoist is equipped with other optional features effected by power supply voltage, reconnect as per instructions included on the component.
16. Conductors supplying power to the hoist and associated equipment must be sized to maintain the operating voltage at the hoist at plus or minus 10% of the nominal operating voltage at all times. Standard nominal operating voltages are 200, 208, 230, 460, and 575 volts.
 17. Conductors supplying power to the hoist and associated equipment must be protected against short circuit and over-current conditions in compliance with ANSI/NFPA 70, National Electrical Code. These requirements are listed in Article 610 and are the responsibility of the owner/user. It is also the responsibility of the owner/user to insure that all protective devices and associated wiring comply with applicable Federal, State, and Local Codes.

INSTALLING HOIST:

1. **Stationary or Lug Mounting:** Fasten securely with wall or base mounting fixtures or lug suspension pins. Check that there are no obstructions to the operation of the hoist including the path of the rope. On winch type units, the fleet angle of the rope feeding off the drum should not exceed 4°.
2. **Top Running Trolley Hoist Units:** Place trolley hoist in correct position adjacent to bridge beams, orienting it for proper end approach in accordance with specification requirements. Be sure collectors and conductors are properly positioned and aligned. Place trolley hoist unit in position on bridge beams. Check that trolley bumpers, if provided, meet trolley stops on crane, and reposition if necessary.
3. **Under Running Trolley Hoist Unit:** Trolley or trolleys are mounted on hoist unit and shipped as one unit. Trolley wheels have a dual tread and will operate on standard S-shapes having 9 1/2° slope flanges or W-shapes having flat flanges. Proceed as follows:
 - a. If trolley hoist is mounted on a skid, do not remove it immediately. The skid will hold the trolley hoist unit in an upright position until assembled on the crane or monorail.
 - b. Trolley shipping restraining rods are used on some of the single stud 4-wheel trolleys. If present, these rods will be located below the wheels and above the trolley stud. Remove and dispose of these rods before placing the hoist in operation.
 - c. Check trolley wheel spacing between wheel flanges even if the unit was ordered for a specific beam size or beam flange width.
 - d. Check trolley dimension D between wheel flanges at tread of wheel as shown in Figure 1. Dimension D must be at least 1/8 inch (3.2 mm) greater than the beam flange width, and not more than 1/4 inch (6.4 mm) greater than the beam flange width. Rearrange washers, if necessary, to achieve proper spacing. Distribute washers equally between positions B and C so that the hoist will be centered between trolley side plates and under beam. A difference of one washer between positions B and C is permissible. **NOTE:** Some trolleys, especially two-wheel swiveling trolleys, do not have washers for adjustment. The trolley crosshead varies in width according to the beam size and flange width. If this type trolley is furnished and the wheel spacing between flanges does not fit the beam flange width to be mounted upon, contact Acco Material Handling Solutions or the distributor of the hoist.

INSTALLATION

FIGURE 1

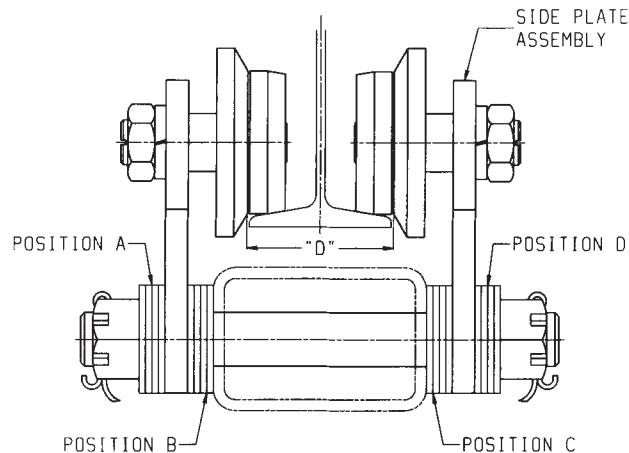

- e. Place trolley hoist in correct position relative to bridge beam or monorail, orienting it for proper end approach in accordance with specification requirements. Be sure collectors and conductors are properly positioned and aligned.
- f. Place trolley hoist unit in position on bridge beam or monorail. Check that trolley bumpers, if provided, meet trolley stops on beam, and reposition if necessary.

The simplest way to mount the trolley hoist on the beam, if crane or building construction permits it, is to remove the trolley stops on an open end of the beam, run the trolley onto the beam, and replace the trolley stops. If this method is not possible because of crane or building interference, mount the trolley hoist according to the following instructions, referring to Figure 1.

- (1) Remove side plate assembly, with wheels intact, from one side of trolley only. On geared and motorized trolleys, it is recommended that the side with the plain wheels be removed.
- (2) Be sure that distribution of washers at positions B and C will allow the proper clearance between beam flange width and wheel flanges.
- (3) Position wheels of side plate assembly still attached to hoist on the beam flange.
- (4) Replace side plate assembly removed in step (1) by sliding it over protruding trolley studs, with washers distributed as prior to dis-assembly at positions A and D, and positioning wheels on the beam flange. Secure trolley stud nuts as follows:
 - Tighten slotted nuts using a wrench until snug.
 - Back off to next slot in nut that aligns with cotter pin hole and secure with cotter pins.

Trolleys using variable width crossheads in place of washers have bolts through side plates that screw into tapped holes in the crosshead. Replace bolts using a lock washer under the bolt head. Tighten bolt until lock washer flattens.

- (5) Check that hoist is centered between trolley side plates and centered under beam.
- (6) Check clearance between wheel flange and beam flange at tread of wheel. Clearance should be $\frac{1}{16}$ inch (1.6 mm) to $\frac{1}{8}$ inch (3.2 mm) on each side, or $\frac{1}{8}$ inch (3.2 mm) to $\frac{1}{4}$ inch (6.4 mm) total.
- (7) Check that all studs, bolts, lock washers, nuts, and cotter pins have been replaced.
- (8) Check that collectors are positioned for proper contact with conductors.

SPRING LOADED COLLECTORS - Set midway between free state and collapsed state.

TOW TYPE COLLECTORS - Make sure they are properly seated. Check that towing harness allows collector shoes to operate freely and will not foul on other objects.

INSTALLATION

4. If top running trolley hoist unit or under running hoist unit was installed on a crane prior to installing the crane, the trolley wheels should be blocked to keep the trolley hoist from moving until the crane is completely installed. If stop angles are welded to the beam to act as blocks and to be removed after crane installation, DO NOT weld them on surfaces where wheels or rollers will operate.
5. On hand chain operated trolleys, unless otherwise specified, the length of the trolley hand chain is based on the standard lift of the hoist model. If the hand chain length must be shortened, find the open link in the chain and open enough to release the adjoining link. Cut the hand chain to required length, remove any twist in chain and reassemble to open link, and close the open link.
6. If pendant control cable is too long, it may be shortened only under the following conditions:
 - a. Only a qualified electrician should perform this work.
 - b. If hoist is connected to the main power supply, de-energize, lock, and tag the main switch (disconnect) in accordance with step 11 of "prior to installing hoist" instructions.
 - c. Shorten cable at the hoist end. DO NOT disturb connections inside the pendant station.
 - d. Check that all wires shortened are reconnected the same as originally connected. Refer to electrical wiring diagram located inside control enclosure.
 - e. Shorten the strain chain an amount equal to the length the cable was shortened. This is to assure that any strain caused by pulling on the pendant control will be absorbed by the strain chain. To check, pull firmly on the pendant station. When strain chain becomes taut, there should be some slack in the cable. If cable is taut and strain chain is slack, remove additional length of strain chain. DO NOT USE until a condition of taut strain chain and slack cable is achieved.
7. Trolley hoists are balanced at the factory based upon the condition of the hoist "as ordered" and "as shipped". Auxiliary equipment or devices furnished and mounted by others may require additional counterweight to balance the hoist and is the responsibility of the party mounting such auxiliary equipment or devices. Lug mounted, deck mounted, top running trolley hoists, winch units, and all hoists furnished without components, such as motors, control, etc., are not balanced at the factory. Hoist must hang level without a load.
8. Load block must hang straight and directly under the hoist drum. Check that limit switch weight hangs freely suspended by its cable, and that nothing interferes with its normal movement. Wire rope must be free of kinks or twists or any other damage that has distorted the rope structure. If rope is damaged, DO NOT USE hoist until rope is replaced. Check any sheaves mounted in the hoist frame for free and unobstructed rotation and movement. The hook throat opening should be measured and recorded for future reference in hook inspection and replacement. Refer to the HOOKS section of this manual.

CONNECTING POWER SUPPLY TO HOIST:



1. DISCONNECT POWER AND LOCKOUT DISCONNECTING MEANS BEFORE CONNECTING POWER SUPPLY TO HOIST.
2. Only a qualified electrician should connect the power supply to the hoist.

INSTALLATION

3. Check power supply that will be furnished to the hoist. It must be the same as shown on the hoist serial number plate. If the power supply that will be connected to the hoist is not the same as shown on the hoist serial number plate, **DO NOT** connect power supply to hoist. Refer to step 15 of "PRIOR TO INSTALLING HOIST" instructions.
4. Make all electrical connections in accordance with wiring diagram located in control enclosure.

BEFORE OPERATING HOIST:

1. Before energizing the power supply, and inspecting and testing the hoist prior to initial operational use, check that all electrical connections are in accordance with the wiring diagram located in hoist control enclosure.
2. ASME B30.16 requires that all new, altered, or modified hoists be inspected by a designated person prior to initial use to verify that the equipment and installation comply with applicable provisions of the standard. Such an inspection should be performed at this time, using ASME B30.16 as the basis for inspection procedures.
3. Energize the power supply to the hoist.
4. Check hoist travel for correct hook motion (hoist motor is properly phased). Since motor rotation of a three-phase AC motor can be changed by reversing any two of the lines feeding power to the motor, the direction of hook motion must be checked to verify that it is correct in accordance with the hoist control device markings.

To check hook motion direction or motor phasing:

DO NOT ACTIVATE THE DOWN BUTTON OR LEVER OF THE HOIST CONTROL DEVICE. MOMENTARILY activate the UP button or lever of the hoist control device and observe the direction of hook motion. If direction of hook travel agrees with the direction marking of the hoist control device activated (i.e., hook direction is UP when the hoist UP control device is activated), hoist motor is properly phased and proceed to step 5. If the direction of hook travel does not agree with the direction marking of the hoist control device activated (i.e., hook direction is DOWN when the hoist UP control device is activated), hoist motor is improperly phased and must be corrected. **DO NOT USE HOIST** until motor phasing is corrected.

WARNING

DO NOT OPERATE HOIST IF DIRECTION OF HOOK MOTION DOES NOT AGREE WITH THE DIRECTION MARKING ON THE HOIST CONTROL DEVICE ACTIVATED.

WARNING

DO NOT ATTEMPT TO CORRECT AN IMPROPERLY PHASED HOIST BY CHANGING ANY WIRING IN THE HOIST CONTROL DEVICE OR AT THE HOIST CONTACTORS; OR BY CHANGING THE MARKINGS ON THE HOIST CONTROL DEVICE.

To correct hoist motor phasing:

DANGER

- a. **DISCONNECT POWER AND LOCKOUT DISCONNECTING MEANS BEFORE RECONNECTING (REVERSING) POWER LINES TO HOIST.**
- b. Only a qualified electrician should reconnect the power lines to the hoist.

INSTALLATION

- c. Interchange any two lines supplying power to the hoist.
 - d. Re-energize power supply to the hoist.
 - e. Re-check hoist travel for correct hook motion. If direction of hook travel agrees with the direction marking of the hoist control device activated (i.e., hook direction is UP when the hoist UP control device is activated), hoist motor is properly phased and proceed to step 5. If the direction of hook travel does not agree with the direction marking of the hoist control device activated (i.e., hook direction is DOWN when the hoist UP control device is activated), hoist motor is improperly phased and must be corrected by repeating steps a through e.
5. If hoist has a motorized trolley, check trolley travel motion for agreement with the direction marking of the trolley control device.

To check trolley motion direction or trolley motor phasing:

MOMENTARILY activate one button or lever of the trolley control device and observe the direction of trolley motion. If direction of trolley travel agrees with the direction marking of the trolley control device activated (i.e., trolley direction is EAST when the trolley EAST control device is activated), trolley motor is properly phased. If the direction of trolley travel does not agree with the direction marking of the trolley control device activated (i.e., trolley direction is WEST when the trolley EAST control device is activated), trolley motor is improperly phased and must be corrected. **DO NOT USE TROLLEY** until motor phasing is corrected.

WARNING

DO NOT OPERATE TROLLEY IF DIRECTION OF TROLLEY MOTION DOES NOT AGREE WITH THE DIRECTION MARKING ON THE TROLLEY CONTROL DEVICE ACTIVATED.

WARNING

DO NOT ATTEMPT TO CORRECT AN IMPROPERLY PHASED TROLLEY BY CHANGING ANY WIRING IN THE TROLLEY CONTROL DEVICE OR AT THE TROLLEY CONTACTORS; OR BY CHANGING THE MARKINGS ON THE TROLLEY CONTROL DEVICE.

To correct trolley motor phasing:

DANGER

- a. DISCONNECT POWER AND LOCKOUT DISCONNECTING MEANS BEFORE RECONNECTING (REVERSING) POWER LINES TO TROLLEY.
 - b. Only a qualified electrician should reconnect the power lines to the trolley.
- c. Interchange any two lines supplying power to the trolley motor only. DO NOT reverse main power leads to the hoist as this will also effect the phasing of the hoist motor.
 - d. Re-energize power supply to the hoist.
 - e. Re-check trolley travel for correct trolley motion. If direction of trolley travel agrees with the direction marking of the trolley control device activated (i.e., trolley direction is LEFT when the trolley LEFT control device is activated), trolley motor is properly phased. If the direction of trolley travel does not agree with the direction marking of the trolley control device activated (i.e., trolley direction is RIGHT when the trolley LEFT control device is activated), trolley motor is improperly phased and must be corrected by repeating steps a through e.

INSTALLATION

6. If hoist is trolley mounted, check that end stops are installed on all open ends of the monorail or bridge girder. If end stops are not present on all open ends, DO NOT operate trolley until end stops are installed.
7. Operate hoist in the raising and lowering direction, without load on the hook, and stop motion to check operation of the motor brake. The drift of the hook should not exceed one inch in either direction.
8. Complete hoists are furnished standard with a gravity type upper limit switch. An optional geared limit switch will be furnished when specified in addition to the standard gravity upper limit switch. All limit switches must be operating and must be checked.

The optional geared type limit switch operates in relation to drum turns. If the wire rope does not track in the drum grooves or if the wire rope over wraps on the drum, the relationship between turns of the drum and turns of the upper geared limit device circuit become out of sequence; and the load block will travel up to the hoist frame and drum area of the hoist before the upper limit device circuit is activated. While the hoist should never be operated with the wire rope not seated in the drum grooves or with over wrapping of the wire rope on the drum, the gravity type limit switch is furnished with the optional geared limit switch in case such a situation occurs wherein the upper geared limit device becomes out of sequence with drum turns. For this reason, the optional geared upper limit device circuit must trip prior to the load block hitting the gravity-type limit switch weight.

Check operation of limit switch or switches as follows:

- a. All checking of limit switches should be accomplished without a load on the hook. All checking of limit switches should be accomplished by using the low speed of multiple-speed hoists, or inched into the limit if the hoist is a single-speed unit.



DISCONNECT POWER AND LOCKOUT DISCONNECTING MEANS BEFORE ADJUSTING LIMIT SWITCHES. LIMIT SWITCHES SHOULD BE ADJUSTED USING A CONTINUITY TESTER OR OTHER TYPE OF TESTER THAT WILL INDICATE OPEN OR CLOSED CIRCUITS WITHOUT THE NEED OF ELECTRICAL POWER.

Only a qualified electrician should adjust switches.

- b. Hoists with the standard gravity type upper limit switch:

- (1) Check the gravity type upper limit switch by operating the hoist in the lifting direction. While the load block is raising, lift the weight of the upper gravity type limit switch manually until motion of the load block stops. Lifting the weight higher should cause the load block to lower until the weight is released. If raising motion does not stop when the weight is lifted, STOP hoist motion as the upper gravity limit switch requires adjustment or replacement. The lowering motion achieved by lifting the weight after raising motion of the load block has stopped is a reverse plugging feature to minimize the possibility of the load block striking the hoist frame or drum if the motor brake is out of adjustment. If adjustment of the gravity type upper limit switch is required, refer to the LIMIT SWITCHES section of this manual.
- (2) Operate hoist in the lifting direction to a point where the block is about 12 inches below the hoist drum. If the hoist has more than one speed, continue to raise at low speed or; if hoist is a single-speed unit, inch the load block in the lifting direction until motion of the load block stops. This is to check that load block stops when striking the weight of the gravity upper limit switch before striking any other part of the hoist. If the load block will hit any part of the hoist prior to striking the weight of the gravity type limit switch, STOP hoist motion as the upper gravity limit switch requires adjustment or replacement. If adjustment of the gravity type upper limit device is required, refer to the LIMIT SWITCHES section of this manual.
- (3) Operate the hoist in the lowering direction until the load block reaches its lowest point of travel. At this location of the load block two wraps of wire rope must remain at each anchorage on the hoist drum. IF LESS THAN TWO WRAPS REMAIN AT EACH ANCHORAGE ON THE DRUM, DO NOT USE THE HOIST AT THIS LOCATION. Contact Acco Material Handling Solutions or the distributor of the hoist.

INSTALLATION

WARNING

HOISTS THAT ARE LOCATED WHERE THE LOAD BLOCK CAN BE LOWERED INTO PITS OR LOWERED TO OTHER LEVELS BELOW THE OPERATING FLOOR LEVEL OF THE HOIST MUST HAVE A LOWER LIMIT SWITCH IN ACCORDANCE WITH ANSI B30.16. IF THE HOIST IS TO BE USED IN SUCH AN APPLICATION AND IT DOES NOT HAVE A LOWER LIMIT SWITCH, DO NOT USE THE HOIST; CONTACT ACCO MATERIAL HANDLING SOLUTIONS OR THE DISTRIBUTOR OF THE HOIST.

c. Hoists with the standard gravity type upper limit switch and an optional geared type upper and lower limit switch:

- (1) Operate hoist in the lowering direction until motion of the load block stops to check lower geared limit device circuit. While lowering the load block, watch the wire rope paying off the drum. If all the wire rope will pay off the drum before the lower geared limit device stops load block motion, STOP hoist motion as the lower geared limit device requires adjustment. The hoist lower geared limit device is set at the factory to stop lower travel of the load block with two wraps of wire rope remaining at each anchorage on the drum. ASME B30.16 allows one wrap of wire rope remaining at each anchorage on the drum when a lower limit device is used. It is recommended that the lower geared limit device be set to prevent the load block from resting on the floor and allowing the hoisting ropes to go slack. If adjustment of the lower geared limit device is required, refer to the LIMIT SWITCHES section of this manual.
- (2) Operate hoist in the lifting direction to a point where the block is about 12 inches below the hoist drum. If the hoist has more than one speed, continue to raise at low speed or; if hoist is a single-speed unit, inch the load block in the lifting direction until motion of the load block stops to check upper geared limit switch circuit. If the load block will hit the weight of the gravity type limit switch before the upper geared limit device stops load block motion, STOP hoist motion as the upper geared limit device requires adjustment. The hoist upper geared limit device is set at the factory to stop upper hook travel when the top of the load block is two inches below the weight of the gravity type limit switch. If adjustment of the upper geared limit device is required, refer to the LIMIT SWITCHES section of this manual.

WARNING

OPTIONAL GEARED UPPER LIMIT DEVICE MUST BE ADJUSTED SO THAT WHEN IT IS TRIPPED, THERE IS A MINIMUM OF 2 INCHES BETWEEN THE TOP OF THE LOAD BLOCK AND THE WEIGHT OF THE GRAVITY TYPE UPPER LIMIT SWITCH.

- d. An optional hoist power-circuit limit switch is available when specified. A power circuit limit switch is checked in the same manner as the gravity type upper limit switch by manually lifting the limit switch tripping device while operating the hoist in the lifting direction.

WARNING

NEVER OPERATE HOIST WITHOUT THE PROTECTION OF PROPERLY FUNCTIONING LIMIT SWITCHES.

HOIST LIMIT SWITCHES SHALL NOT BE USED AS A NORMAL MEANS OF STOPPING TRAVEL MOTION OR THE LOAD. THESE ARE EMERGENCY DEVICES ONLY.

THE PRIMARY UPPER AND LOWER LIMIT SWITCH SHOULD BE CHECKED WITHOUT LOAD ON THE HOOK AT THE START OF EACH SHIFT, OR THE FIRST TIME HOIST IS TO BE OPERATED DURING EACH SHIFT.

THESE INSTRUCTIONS APPLY TO LIMIT SWITCH ADJUSTMENT FOR AN UNLOADED LOAD BLOCK ONLY. LIMIT SWITCHES MUST BE ADJUSTED TO PREVENT THE LOAD BLOCK OR THE LOAD BEING LIFTED FROM COMING INTO CONTACT WITH ANY PART OF THE HOIST; OR THE CRANE, HOIST SUPPORT STRUCTURE, OR OTHER EQUIPMENT WHERE THE HOIST IS INSTALLED.

INSTALLATION

9. Winch type units may be furnished with only an optional geared type limit switch or without any type of limit switch depending upon ordering specifications. The majority of winch units are furnished without wire rope, or with wire rope lengths to be reeved into a system of sheaves designed by others. Therefore, the standard gravity type limit switch mounted on the hoist frame has no effect on the relative upper limit position of the load block or load. **THEREFORE,**

WARNING

SYSTEM DESIGNERS, MANUFACTURERS, AND/OR OWNERS/USERS OF SYSTEMS USING A WINCH TYPE UNIT ARE RESPONSIBLE FOR THE INSTALLATION AND ADJUSTMENT OF LIMIT SWITCHES IN THE LIFTING SYSTEM TO PREVENT THE LOAD BLOCK OR THE LOAD BEING LIFTED FROM COMING INTO CONTACT WITH ANY PART OF THE WINCH; OR THE SYSTEM, SYSTEM SUPPORT STRUCTURE, OR OTHER EQUIPMENT THAT IS PART OF THE SYSTEM WHERE THE WINCH IS INSTALLED.

10. Operate the hoist without a load on the hook through the entire lifting range to check that limit switches function properly and that load block and hook do not interfere with any other items or pieces of equipment located in the operating area.
11. If hoist has a trolley, operate the trolley, without a load on the hoist hook, for the entire travel distance of the trolley to check that trolley, hoist, load block, and hook do not interfere with any other items or pieces of equipment located in the path of travel.
12. Hoist is now ready to be load tested, if required.

HOIST LOAD TEST:

1. Complete hoists are load tested by Acco in accordance with ASME B30.16. Exceptions to this procedure could occur if special design features of the hoist do not permit it to be placed in the Acco hoist load test stand. In such cases, the purchaser shall be notified of this fact, and it is the responsibility of the owner/user to load test the hoist in accordance with ASME B30.16.
2. Hoists furnished in an uncompleted condition (i.e. less controls, less motor, less wire rope, etc.) as hoist components, and winch units are not load tested by Acco. Therefore, it is the responsibility of the owner/user to load test the final lifting system using such hoist components or winches in accordance with ASME B30.16.
3. If the hoist is installed on a crane, load testing of the crane in accordance with, as applicable, ASME B30.2, ASME B30.11, or ASME B30.17 may be required.
4. If a load test in accordance with one of the B30 Standards is not required, the hoist should still be operated with a load on the hoist hook prior to being released for operating purposes.
 - a. Attach a load to the hoist hook. Load shall not exceed the rated load capacity of the hoist.
 - b. Before lifting the load, operate the hoist in the raising direction to take any slack out of the hoist wire rope.
 - c. Raise the load a few inches and stop the hoist. If brakes stop and hold the load, continue raising and lowering the load several feet, stopping the hoist several times in each direction to check that the hoist braking system stops and holds the load.
 - d. If the hoist braking system stops and holds the load, the hoist operates in accordance with the control devices, and no unusual sounds are present during operation, the hoist is ready to be released for operating purposes.
 - e. If the hoist braking system does not stop and hold the load, the hoist does not operate in accordance with the control devices, or any unusual sounds are present during operation, the hoist is not ready to be released for operating purposes; and corrective action must be taken.
5. All personnel that will operate the hoist shall read the OPERATION section of this manual, the WARNINGS contained in this manual, and instruction and WARNING labels on the hoist before operating the hoist or lifting system.

OPERATION

Operation of an overhead hoist involves more than activating the buttons or levers of the hoist control device. It is emphasized in the ASME B30 Standards that the use of overhead hoists is subject to certain hazards that cannot be met by mechanical means, but only by the exercise of intelligence, care, common sense, and experience in anticipating the motions that will occur as a result of activating the hoist controls. Certain precautions are necessary before moving the load and this includes the proper rigging of loads to the hoist hook.

WARNING

HOIST OPERATORS SHALL BE REQUIRED TO READ THE OPERATION SECTION OF THIS MANUAL, THE WARNINGS CONTAINED IN THIS MANUAL, INSTRUCTION AND WARNING LABELS ON THE HOIST OR LIFTING SYSTEM, AND THE OPERATION SECTION OF ASME B30.16; AND TO BE FAMILIAR WITH THE HOIST AND HOIST CONTROLS BEFORE BEING AUTHORIZED TO OPERATE THE HOIST OR LIFTING SYSTEM.

HOIST OPERATORS SHOULD BE TRAINED IN PROPER RIGGING PROCEDURES TO BE FOLLOWED IN THE ATTACHMENT OF LOADS TO THE HOIST HOOK.

HOIST OPERATORS SHOULD BE TRAINED TO BE AWARE OF POTENTIAL MALFUNCTIONS OF THE EQUIPMENT THAT REQUIRE ADJUSTMENT OR REPAIR, AND TO BE INSTRUCTED TO STOP OPERATION IF SUCH MALFUNCTIONS OCCUR, AND TO IMMEDIATELY ADVISE THEIR SUPERVISOR SO CORRECTIVE ACTION CAN BE TAKEN.

HOIST OPERATORS SHOULD HAVE NORMAL DEPTH PERCEPTION, FIELD OF VISION, REACTION TIME, MANUAL DEXTERITY, AND COORDINATION.

HOIST OPERATORS SHOULD NOT BE SUBJECT TO SEIZURES, LOSS OF PHYSICAL CONTROL, PHYSICAL DEFECTS, OR EMOTIONAL INSTABILITY THAT COULD RESULT IN ACTIONS OF THE OPERATOR BEING A HAZARD TO THE OPERATOR OR OTHERS.

HOIST OPERATORS SHOULD NOT OPERATE A HOIST OR LIFTING SYSTEM WHEN UNDER THE INFLUENCE OF ALCOHOL, DRUGS, OR MEDICATION.

OVERHEAD HOISTS ARE INTENDED ONLY FOR VERTICAL LIFTING SERVICE OF FREELY SUSPENDED UNGUIDED LOADS. DO NOT USE HOIST FOR LOADS THAT ARE NOT LIFTED VERTICALLY, LOADS THAT ARE NOT FREELY-SUSPENDED, OR LOADS THAT ARE GUIDED. IF SUCH CONDITIONS EXIST, CONTACT ACCO MATERIAL HANDLING SOLUTIONS.

BEFORE EACH SHIFT OR BEFORE THE FIRST TIME THE HOIST IS TO BE USED EACH SHIFT:

THE OPERATOR:

- SHALL visually inspect wire rope for broken wires, broken strands, kinks, and any type of deformation or damage of the rope structure.
- SHALL visually inspect hooks for nicks, gouges, deformation of the throat opening, wear on saddle or load bearing point, and twisting.
- SHALL visually inspect hook latches for proper operation or damage that does not allow proper operation.
- SHALL replace warning label if missing or illegible.

OPERATION

SHALL report any damage or malfunctions to the supervisor.

SHALL NOT operate hoist if any damage or malfunctions exist.

SHALL NOT operate hoist if it is tagged with an out-of-order sign.

BEFORE OPERATING THE HOIST AND APPLYING THE LOAD:

THE OPERATOR:

SHALL be familiar with all operating controls of the hoist.

SHALL be familiar with the OPERATION Section of this manual, the WARNINGS contained in this manual, instructions and WARNING labels on the hoist and lifting system, and the OPERATION Section of ASME B30.16.

SHALL be instructed in the operation or operations to be performed.

SHALL NOT operate hoist if any damage or malfunctions exist; and SHALL report any damage or malfunctions to the supervisor.

SHALL NOT operate hoist if it is tagged with an out-of-order sign.

SHALL center hoist over load.

SHALL NOT use the hoist wire rope as a sling to wrap around the load.

SHALL attach the load to the hoist hook by suitable means such as slings or lifting devices.

SHALL only attach loads to the hoist hook that do not exceed the rated load capacity of the hoist.

SHALL verify that the size of the attachment of the sling or other lifting device to be used is compatible with the size of the hoist hook.

SHALL verify that the attachment part of the sling or other lifting device is properly seated in the base, bowl, or saddle of the hoist hook.

SHALL verify that the hook latch operates properly and that the hook latch properly bridges and closes the hook throat opening.

SHALL verify that the latch of the hoist hook will not support any part of the load.

SHALL verify that the load or any part of the load will not be applied to and/or not supported by the tip or point of the hook.

SHALL verify that load will be properly balanced when it is lifted.

SHALL verify that side loads will not be applied to the hoist when the load is lifted.

SHALL verify that hoist wire rope is not kinked or twisted, and that wire rope parts are not twisted about each other.

SHALL verify that hoist wire rope is properly seated in the drum grooves and sheaves.

SHALL notify personnel in the area that a load will be lifted and verify that all personnel are clear of the load.

SHALL verify that when the load is lifted, it will clear all material, machinery, or other obstructions in the area.

OPERATION

WHILE OPERATING THE HOIST AND MOVING THE LOAD:

THE OPERATOR:

- SHALL NOT engage in any activity that will divert the attention of the operator.
- SHALL NOT lift, lower, or transport a load with the hoist until the operator and all other personnel are clear of the load and the path of the load.
- SHALL verify that the load and hoist will clear all obstacles before moving or rotating the load.
- SHALL avoid moving loads over personnel.
- SHALL NOT lift, lower, or transport personnel by means of the hoist, trolley, hoist hook, or load.
- SHALL slowly inch the hook into engagement with the load to eliminate wire rope slack and reduce impact loading of the hoist.
- SHALL avoid unnecessary inching and quick reversals of direction.
- SHALL only lift the load a few inches to verify that the load is properly balanced before continuing with the lift.
- SHALL only lift the load a few inches to verify that the hoist braking system is functioning properly before continuing with the lift.
- SHALL avoid swinging of the load or hoist hook when the hoist is traveling.
- SHALL avoid sharp contact between trolleys or between trolleys and stops.
- SHALL NOT use hoist limit switches or devices as a normal means of stopping the hoist.
- SHALL NOT lower the load beyond the point where less than two wraps of wire rope remain at each anchorage on the drum, unless a lower limit device is provided, in which case no less than one wrap of wire rope shall remain at each anchorage on the drum.

PARKING THE LOAD:

THE OPERATOR:

- SHALL NOT lower a load with the hoist until the operator and all other personnel are clear of the load and the path of the load.
- SHALL verify that the load will clear all obstacles before lowering the load.
- SHALL block loads before landing if slings or other lifting devices must be removed from under the landed load.
- SHALL exercise care when removing a sling from under a landed and blocked load.
- SHALL NOT leave a suspended load unattended unless specific precautions to prevent the load from inadvertent lowering have been instituted and are in place.
- SHALL position the hoist load block and hook above head level for storage when the hoist is not in use.

OPERATION

GENERAL:

THE OPERATOR:

SHALL know hand signals used for hoist and crane operations if a signal-person is used in the operation, and accept signals of only persons authorized to give hand signals EXCEPT to obey a stop signal regardless who gives it.

SHALL NOT adjust or repair a hoist unless qualified and authorized to perform maintenance.

SHALL NOT use a hoist load limiting device as a means to measure the load.

GENERAL DO'S AND DO NOT'S:

DO establish a regular inspection schedule and maintain a record of all inspections performed with special attention directed to wire ropes, hooks, and brakes.

DO remove the hoist from service and perform necessary maintenance and repair.

DO follow recommended maintenance procedures for taking a hoist out of service to inspect and perform maintenance and repair.

DO use the original hoist manufacturer's recommended parts when repairing a hoist and replacing worn or damaged parts.

DO NOT allow unqualified or unauthorized personnel to operate, inspect, maintain, or repair the hoist.

DO NOT operate a hoist that is damaged or has any actual or suspected mechanical or electrical malfunction.

DO NOT attempt to lengthen wire rope or repair damaged wire rope.

DO NOT use the wire rope, any part of the hoist, or the load block and hook as a ground for welding.

DO NOT allow a welding electrode to be touched to the wire rope.

DO NOT remove or obscure any warnings or warning labels on the hoist.

DO NOT walk under a suspended load.

DO NOT perform ANY work on a suspended load that requires a worker to be positioned under the suspended load.

⚠ WARNING

DO NOT WALK UNDER A SUSPENDED LOAD.

DO NOT PERFORM ANY WORK ON A SUSPENDED LOAD THAT REQUIRES A WORKER TO BE POSITIONED UNDER THE SUSPENDED LOAD.

IF IT IS ESSENTIAL THAT A WORKER BE POSITIONED UNDER A SUSPENDED LOAD TO PERFORM WORK ON THE SUSPENDED LOAD; SUCH WORK SHALL NOT BE STARTED OR PERFORMED UNTIL OTHER AUXILIARY SUPPORTING MEANS ARE PLACED UNDER THE SUSPENDED LOAD. FAILURE TO USE OTHER AUXILIARY SUPPORTING MEANS COULD RESULT IN SERIOUS BODILY INJURY OR DEATH, AND/OR PROPERTY DAMAGE.

MOTOR OVERLOAD FEATURES

Complete hoists are furnished with several motor overload features. These features de-energize the hoist motor or the hoist control circuit for the purpose of stopping operation of the hoist when a condition arises that makes it unwise, or even hazardous, for continued operation. Therefore, if the hoist should stop during operation, or if the hoist should fail to pick up a load, first consider and investigate these motor overload features. Standard features, unless otherwise specified, on complete hoists include:

- Overload Cutoff Device
- Limit Switches
- Motor Thermostats
- Motor Brake Interlock Switch

OVERLOAD CUTOFF DEVICE:

The WRIGHT® overload cutoff device is standard on all complete hoists, unless otherwise specified. The WRIGHT® overload cutoff device is not supplied with winch type units or single line units.

The WRIGHT® overload cutoff device is an electro-mechanical device designed to interrupt the hoist lifting circuit if the load it senses exceeds the preset capacity of the overload cutoff device. When the device interrupts the hoist lifting circuit, the lowering circuit remains intact to allow the hoist load to be lowered and removed. When the excessive overload, that has caused the device to trip, is removed from the hoist hook, the hoist lifting circuit is automatically restored. Under normal operating conditions, the WRIGHT® overload cutoff device will allow the hoist to lift 110% of rated load, but will not allow the hoist to lift 125% of rated load. Refer to the OVERLOAD CUTOFF DEVICE section of this manual for instructions if adjustment of the overload cutoff device is required.

WARNING

THE WRIGHT® OVERLOAD CUTOFF DEVICE IS DESIGNED TO PERMIT THE HOIST TO LIFT A FREELY SUSPENDED LOAD WITHIN ITS RATED LOAD CAPACITY AND TO LIMIT THE AMOUNT OF OVERLOAD THAT CAN BE LIFTED BY A PROPERLY MAINTAINED HOIST, UNDER NORMAL OPERATING CONDITIONS.

VARIABLES EXPERIENCED WITHIN THE HOISTING SYSTEM, SUCH AS, BUT NOT LIMITED TO, ACCELERATION OF THE LOAD, DYNAMICS OF THE SYSTEM, TYPE AND LENGTH OF WIRE ROPE, AND OPERATOR EXPERIENCE, DO NOT PERMIT THE ADJUSTMENT OF AN OVERLOAD CUTOFF DEVICE THAT WOULD PREVENT THE LIFTING OF ANY OVERLOAD OR LOAD IN EXCESS OF RATED LOAD CAPACITY.

PROPER ADJUSTMENT OF THE WRIGHT® OVERLOAD CUTOFF DEVICE WILL ALLOW THE LIFTING OF AN OVERLOAD OF SUCH MAGNITUDE THAT WILL NOT CAUSE PERMANENT DAMAGE TO A PROPERLY MAINTAINED HOIST, TROLLEY, OR CRANE; AND WILL PREVENT THE LIFTING OF AN OVERLOAD OF SUCH MAGNITUDE THAT COULD CAUSE PERMANENT DAMAGE TO A PROPERLY MAINTAINED HOIST, TROLLEY, OR CRANE.

THE WRIGHT® OVERLOAD CUTOFF DEVICE IS ACTUATED ONLY BY LOADS INCURRED WHEN LIFTING A FREELY SUSPENDED LOAD ON THE HOIST HOOK. THEREFORE, THE WRIGHT® OVERLOAD CUTOFF DEVICE CANNOT BE RELIED UPON TO RENDER THE HOISTING MECHANISM INOPERATIVE IF OTHER SOURCES, SUCH AS, BUT NOT LIMITED TO, SNAGGING OF THE LOAD, TWO BLOCKING OF THE LOAD BLOCK, OR SNATCHING A LOAD, INDUCE LOADS INTO THE HOISTING SYSTEM.

THE WRIGHT® OVERLOAD CUTOFF DEVICE IS CONNECTED IN THE HOIST LIFTING CONTROL CIRCUIT AND, THEREFORE, WILL NOT PREVENT DAMAGE TO THE HOIST, TROLLEY, OR CRANE IF EXCESSIVE OVERLOADS ARE INDUCED INTO THE HOISTING SYSTEM WHEN THE HOISTING MECHANISM IS IN A NON-OPERATING OR STATIC MODE.

THE WRIGHT® OVERLOAD CUTOFF DEVICE IS AN EMERGENCY DEVICE ONLY AND SHALL NOT BE USED TO MEASURE THE MAXIMUM LOAD TO BE LIFTED, OR TO SENSE ANY OVERLOAD IMPOSED BY A CONSTRAINED LOAD.

MOTOR OVERLOAD FEATURES

LIMIT SWITCHES:

A gravity type upper limit switch is standard on all complete hoists, unless otherwise specified. An optional upper and lower geared limit switch is available when specified. Limit switches are not supplied with winch type units or single line units unless specified.

These limit switches are described in item 8 of "BEFORE OPERATING HOIST" instructions of the INSTALLATION section of this manual. If the hoist should stop during operation, or if the hoist should fail to pick up a load, check to determine if one of the limit switches has tripped. Refer to the LIMIT SWITCHES section of this manual for instructions if adjustment of either the geared type limit switch or the gravity type limit switch is required.

MOTOR THERMOSTATS:

A bi-metallic, automatic thermostat is built into the motor windings. This thermostat will cause the motor control to be de-energized when the temperature of the motor winding exceeds a predetermined temperature limit. It provides full running protection against motor overheating. The motor control will continue to be de-energized until the temperature of the winding is reduced below the temperature cutoff point and then the hoist may be operated as before.

HOIST MOTOR BRAKE INTERLOCK SWITCH:

The WRIGHT® hoist motor brake is a direct-acting, disc-type brake, operated by rectified direct current. Unless otherwise specified, it is equipped with an interlocking switch designed to reduce the coil voltage after the brake has opened to reduce coil heating; and to prevent the motor from starting before the brake is released or if the brake does not release. The switch is activated when the brake armature plate moves against the brake magnet. If the brake does not open because adjustment is required, the brake interlock switch will not be activated and the hoist motor will not start. Refer to the HOIST MOTOR BRAKE section of this manual for instructions if adjustment of the hoist motor brake is required.

WARNING

THE HOIST MOTOR BRAKE INTERLOCK SWITCH FEATURE IS NOT FURNISHED ON HOISTS SPECIFIED FOR OPERATION IN HAZARDOUS LOCATIONS; HOISTS SPECIFIED WITH HOIST MOTOR BRAKE TYPES OTHER THAN THE WRIGHT® HOIST MOTOR BRAKE; OR INVERTER-CONTROLLED HOISTS. THE HOIST MOTOR BRAKE INTERLOCK SWITCH IS PRESENT ON INVERTER-CONTROLLED HOISTS, BUT WILL NOT PREVENT THE MOTOR FROM STARTING IF THE HOIST MOTOR BRAKE DOES NOT OPEN.

OPTIONAL ITEMS:

Other motor overload features may be furnished on the hoist as specified; furnished by others as part of a crane or lifting system that utilizes the hoist; or installed as part of the system or building by the installer or owner/user of the hoist as required by ANSI/NFPA 70, National Electrical Code, or applicable Federal, State, or Local Codes. Such items could include thermal overload relays, branch circuit fuses, or main line fuses. Refer to wiring diagram located in the hoist control enclosure to determine if any additional motor overload features are furnished with the hoist. If the hoist is installed in a crane or lifting system designed and manufactured by others, refer to the wiring diagram for the crane or lifting system to determine if any additional motor overload features are furnished as part of the crane or lifting system.

MAINTENANCE AND INSPECTION PROCEDURES

Hoists shall be maintained, inspected, and tested in accordance with the MAINTENANCE AND REPAIR section and INSPECTION AND TEST section of this manual and in accordance with the intervals and requirements of ASME B30.16. Cranes shall be maintained, inspected, and tested in accordance with the manual furnished by the crane manufacturer and in accordance with the intervals and requirements of, as applicable, ASME B30.2, ASME B30.11, or ASME B30.17.

Before maintenance or inspections are performed on a hoist, trolley, crane, crane runway, crane runway or monorail support, or crane runway or monorail conductors, the following precautions shall be taken as applicable.

1. The hoist, trolley, or crane to be inspected, tested, or repaired shall be run to a location where it will cause the least interference with other hoists, cranes, and operations in the area.
2. If a load is attached to the hoist hook, it shall be landed.
3. All controllers shall be placed in the off position.
4. If hoist is trolley suspended, the trolley shall be blocked to prevent trolley movement.
5. If hoist is installed on a crane, the crane shall be blocked to prevent crane movement.

DANGER

6. HAZARDOUS VOLTAGES ARE PRESENT IN THE CONTROL BOX, OTHER ELECTRICAL COMPONENTS, AND CONNECTIONS BETWEEN THESE COMPONENTS.

The main switch (disconnect) of the hoist, crane, or lifting system shall be de-energized. Lock and tag the main switch in the de-energized position in accordance with ANSI Z244.1.

7. Warning signs and barriers shall be utilized on the floor beneath the hoist, crane, or lifting system where overhead maintenance, repair, or inspection work creates a hazardous area on the floor beneath the hoist, crane, or lifting system.
8. If the crane runway or monorail remains energized because other hoists or cranes on the same runway or monorail are in operation, rail stops or a signal person(s), located full-time at a visual vantage point for observing the approach of an active hoist(s) or an active crane(s), shall be provided to prohibit contact by the active hoist(s) or crane(s) with the idle hoist or crane; with persons performing maintenance, repair, or inspection; and with equipment used in performing the maintenance, repair, or inspection.
9. A guard or barrier shall be installed between adjacent runways for the length of the established work area to prevent contact between persons performing maintenance, repair, or inspection and a crane on the adjacent runway.
10. Safe access to the hoist, crane, or lifting system, such as scaffolding, work platforms, etc., shall be provided for personnel that will perform maintenance, repair, or inspection. If personnel are required to work at elevations in excess of 6 feet above floor or ground level, a fall prevention policy and procedure shall be developed, documented, and implemented by the owner/user.
11. After maintenance, repair, or inspection work is completed, and before the hoist, crane, or lifting system is returned to normal operation:
 - a. Any guards on the hoist, crane, or lifting system that were removed to perform maintenance, repair, or inspection work shall be reinstalled.
 - b. Any safety devices on the hoist, crane, or lifting system that were deactivated to perform maintenance, repair, or inspection work shall be reactivated.
 - c. Any parts that were replaced and other loose material shall be removed.
 - d. All equipment used in the maintenance, repair, or inspection work shall be removed.

MAINTENANCE AND INSPECTION PROCEDURES

12. Warning signs, barriers, and guards shall be removed only by authorized personnel.
13. Lock and tag on the main switch (disconnect) of the hoist, crane, or lifting device shall be removed only by the person that locked and tagged the main switch originally, or an authorized person.
14. If the extent of the maintenance or repair work requires any testing as outlined in the INSPECTION AND TEST SECTION of this manual; the manual furnished by the crane manufacturer; or as required by, as applicable, the provisions of ASME B30.16, ASME B30.2, ASME B30.11, or ASME B30.17; such tests shall be conducted before the hoist, crane, or lifting system is returned to normal operation.

INSPECTION

Inspection procedure for hoists in regular service is divided into two general classifications as outlined in ASME B30.16. These two general classifications are based upon the intervals at which inspections should be performed. The intervals are dependent upon the nature of the critical components of the hoist, and the degree of exposure of hoist components and parts to wear and deterioration. The degree of exposure is dependent upon hoist activity, severity of hoist service, and the environment of hoist location. These two general classifications of hoist inspection are designated as frequent and periodic. In addition, daily inspections are required to be performed by the operator at the start of each shift, or at the time the hoist is first used during each shift.

FREQUENT INSPECTION: Frequent inspections are visual inspections and examinations by the operator or other designated personnel with records not required. Nominal inspection intervals are as follows:

Normal service - monthly

Heavy service - weekly to monthly

Severe service - daily to weekly

PERIODIC INSPECTION: Periodic inspections are visual and audio inspections and examinations by designated personnel making records of external conditions to provide the basis for a continuing evaluation of the hoist and components. If the external inspection indicates the need, some disassembly may be required to make a more detailed inspection and examination. Nominal inspection intervals are as follows:

Normal service - annually

Heavy service - semiannually

Severe service - quarterly

WARNING

THE INSPECTION INTERVALS LISTED ABOVE ARE NOMINAL RECOMMENDATIONS FOR REFERENCE PURPOSES ONLY. THEY ARE BASED ON SINGLE SHIFT OPERATION UNDER NORMAL OPERATING CONDITIONS AND NORMAL ENVIRONMENTAL CONDITIONS. ACTUAL OPERATING AND ENVIRONMENTAL CONDITIONS SHOULD BE REVIEWED BY A QUALIFIED PERSON AND INSPECTION INTERVALS ESTABLISHED ON THE RECOMMENDATIONS OF THE QUALIFIED PERSON.

Definitions of service from ASME B30.16 are as follows:

Normal service involves operation of the hoist with randomly distributed loads within the rated load limit, or uniform loads less than 65% of rated load, for not more than 25% of the time for a single work shift.

Heavy service involves operation of the hoist within the rated load limit that exceeds normal service.

Severe service involves operation of the hoist in normal service or heavy service with abnormal operating conditions.

A hoist that is not in regular service, that has been idle for a period of one month or more, but less than one year, shall be inspected in accordance with the requirements for frequent inspection before being placed into service.

A hoist that is not in regular service, that has been idle for a period of one year or more, shall be inspected in accordance with the requirements for periodic inspection before being placed into service.

INSPECTION

Required daily inspection items to be performed by the operator at the start of each shift, or at the time the hoist is first used during each shift are shown in Table 1.

**TABLE 1
DAILY INSPECTIONS BY THE OPERATOR**

INSPECTION ITEM	DESCRIPTION OF INSPECTION CHECK POINTS
Tagged Hoist	Check that hoist is not tagged with an out-of-order sign.
Control Devices	Check that travel motions agree with control device markings.
Hook	Check for damage, cracks, nicks, gouges, deformation of the throat opening, wear on saddle or load bearing point, and twist. Refer to HOOK section of this manual.
Hook Latch	Check that hook latch is not missing and that it operates properly.
Wire Rope	Check for broken wires, broken strands, kinks, and any type of deformation or damage to the rope structure. Refer to WIRE ROPE section of this manual.
Reeving	Check that wire rope is properly reeved and that rope parts are not twisted about each other. Refer to WIRE ROPE section of this manual.
Brakes	Check that hoist and trolley motions do not have excessive drift.
Limit Switches	Check that gravity type upper limit switch stops lifting motion of the hoist load block before striking any part of the hoist. If supplied, check that the upper geared limit device stops lifting motion of the hoist load block two inches below the weight of the gravity type limit switch. If supplied, check that the lower geared limit device stops lowering motion of the hoist hook with two wraps of wire rope at each anchorage on the drum (unless the lower geared limit device is set for one wrap at each anchorage).
Oil Leakage	Check for any sign of oil leakage on the hoist and on the floor area beneath the hoist.
Unusual Sounds	Check for any unusual sounds from the hoist and hoist mechanism while operating the hoist.
Warning Label	Check that warning label is not missing and that it is legible.

⚠ WARNING

IF ANY DAMAGE OR MALFUNCTIONS ARE NOTED BY THE DAILY INSPECTION ITEMS OF TABLE 1, THE OPERATOR SHALL NOT OPERATE THE HOIST, AND SHALL IMMEDIATELY ADVISE THE SUPERVISOR SO CORRECTIVE ACTION CAN BE TAKEN. IF THE HOIST IS TAGGED WITH AN OUT-OF-ORDER SIGN, THE OPERATOR SHALL NOT OPERATE THE HOIST.

HOIST OPERATORS SHOULD BE TRAINED TO BE AWARE OF MALFUNCTIONS OF THE EQUIPMENT DURING OPERATION, AND TO IMMEDIATELY STOP OPERATION IF SUCH MALFUNCTIONS OCCUR, AND TO IMMEDIATELY ADVISE THE SUPERVISOR SO CORRECTIVE ACTION CAN BE TAKEN.

INSPECTION

Recommended items to be checked for deficiencies or damage during frequent and periodic inspections are shown in Table 2. Detailed inspection procedures for some items will be found in specific sections of this manual. These inspections may be performed with the hoist in its normal location and do not require that the hoist be disassembled. Covers and other items normally supplied to allow inspection of components should be opened or removed for these inspections. Any deficiencies or damage such as those listed in Table 2 shall be examined by a designated person to determine whether they constitute a hazard, or whether any disassembly is necessary for a more detailed examination. The hoist operator should make observations during regular operation for any deficiencies or damage that might appear between inspections.

**TABLE 2
FREQUENT AND PERIODIC INSPECTIONS**

INSPECTION ITEM	FREQUENCY		DEFICIENCIES OR DAMAGE TO LOOK FOR
	FREQUENT	PERIODIC	
All functional operating mechanisms	•	•	Maladjustment that interferes with operating mechanisms proper operation and unusual sounds
Control devices	•	•	Improper operation
Limit switch devices (For detailed inspection procedures, refer to LIMIT SWITCH section of this manual)	•	•	Maladjustment or malfunction
Hook (For detailed inspection procedures, refer to HOOK section of this manual. Also refer to ASME B30.10)	•	•	Chemical damage, cracks, deformation, excessive throat opening, twist, and wear on load bearing surface
Hook latch	•	•	Missing or damage that prevents proper operation
Hook retaining members (Nuts, collars, pins, etc.)	•	•	Not properly secured (tightened), damaged or missing parts
Wire rope reeving	•	•	Reeving not in accordance with the WIRE ROPE section of this manual
Wire rope (For detailed inspection procedures, refer to WIRE ROPE section of this manual)	•	•	Broken wires, broken strands, wear, twist, kinks, distortion of rope structure, end connections, deposits of foreign material, heat damage, and in adequate lubrication
WARNING label	•	•	Missing or illegible
Control device markings	•	•	Missing or illegible
Lubricant levels (For detailed inspection procedures, refer to LUBRICATION section of this manual)	•	•	Lubricant must be added or replaced
Fastening devices (bolts, nuts, pins, etc.)	•	•	Not properly secured (tightened), damaged or missing parts

INSPECTION

Drums and sheaves	•	•	Cracks, damage to grooves, and excessive wear
Motor brake (For detailed inspection procedures, refer to MOTOR BRAKE section of this manual)	•	•	Drift and excessive wear
Load brake (For detailed inspection procedures, refer to LOAD BRAKE section of this manual)	•	•	Drift
Load block, suspension frame	•	•	Cracks, damage and distortion
Supporting structure and trolley	•	•	Cracks, damage and distortion
Trolley wheels	•	•	Flat spots, damage excessive wear
Electrical apparatus	•	•	Pitting, deterioration, wear and improper operation
Wiring and fittings	•	•	Loose connections, abraded, cut, or nicked insulation

⚠ WARNING

IF ANY DAMAGE OR MALFUNCTIONS ARE NOTED BY THE FREQUENT OR PERIODIC INSPECTION ITEMS OF TABLE 2, THE HOIST SHALL BE TAGGED WITH AN OUT-OF-ORDER SIGN AND SHALL NOT BE RETURNED TO REGULAR OPERATION UNTIL MAINTENANCE AND REPAIR OF THE DAMAGE OR DEFICIENCIES FOUND DURING THE INSPECTION HAVE BEEN CORRECTED.

Records of the condition of critical components such as wire rope, hooks, and brakes observed during frequent and periodic inspections should be established. This record should also record replacement, maintenance, and repair information. Use of this recorded information will allow a preventative maintenance program to be established for replacement of wearing components on a regular basis, thereby eliminating or reducing unscheduled downtime situations.

If maintenance, adjustment, replacement of parts, or repair of the hoist is required because of any damage or malfunctions noted during the frequent or periodic inspections, refer to the MAINTENANCE AND REPAIR section of this manual and other sections of this manual for specific instructions or parts identification. Before performing any maintenance on the hoist, refer to the MAINTENANCE AND INSPECTION PROCEDURES section of this manual. After performing maintenance, adjustment, or replacement of parts or components, refer to the TEST section of this manual.

TEST

All new complete hoists are load tested by Acco in accordance with ASME B30.16. Exceptions to this procedure could occur if special design features of the hoist do not permit it to be placed in the Acco hoist load test stand. In such cases, the purchaser shall be notified of this fact, and it is the responsibility of the owner/user to load test the hoist in accordance with ASME B30.16.

Hoists furnished in an uncompleted condition (i.e. less controls, less motor, less wire rope, etc.) as hoist components, and winch units are not load tested by Acco. Therefore, it is the responsibility of the owner/user to load test the final lifting system using such hoist components or winches in accordance with ASME B30.16. Refer to the "HOIST LOAD TEST" portion of the INSTALLATION section of this manual for instructions for performing a load test on new hoists or new hoists used in a lifting system.

If the hoist is installed on a crane, load testing of the crane in accordance with, as applicable, ASME B30.2, ASME B30.11, or ASME B30.17 may be required.

Testing of hoists after original installation is required when the hoist has been altered or repaired; has been idle for a period of 12 months or longer; or in accordance with specific testing requirements established by the owner/user. General testing requirements are outlined in ASME B30.16 and should be followed. ASME B30.16 lists two types of hoist tests as follows:

1. Operational test
2. Load Test

ASME B30.16 uses the words **SHALL** and **SHOULD** in listing requirements, and defines these two words as follows:

SHALL - indicates that the rule is mandatory and must be followed.

SHOULD - indicates that the rule is a recommendation, the advisability of which depends on the facts in each situation.

OPERATIONAL TEST:

All altered or repaired hoists, or hoists that have not been used within the preceding 12 months, **SHALL** be tested by the owner/user before being placed in operational service. The operational test is performed without a load on the hook and includes: (1) operation of control devices; (2) lifting and lowering; (3) operation of brakes; and (4) operation and setting of limit switch devices.

Operational test steps are as follows:

1. Check hoist travel for correct hook motion (hoist motor is properly phased). Since motor rotation of a three-phase AC motor can be changed by reversing any two of the lines feeding power to the motor, the direction of hook motion must be checked to verify that it is correct in accordance with the hoist control device markings.

To check hook motion direction or motor phasing:

MOMENTARILY activate the **UP** button or lever of the hoist control device and observe the direction of hook motion. If direction of hook travel agrees with the direction marking of the hoist control device activated (i.e., hook direction is UP when the hoist UP control device is activated), hoist motor is properly phased and proceed to step 5. If the direction of hook travel does not agree with the direction marking of the hoist control device activated (i.e., hook direction is DOWN when the hoist UP control device is activated), hoist motor is improperly phased and must be corrected. **DO NOT USE HOIST** until motor phasing is corrected.

WARNING

DO NOT OPERATE HOIST IF DIRECTION OF HOOK MOTION DOES NOT AGREE WITH THE DIRECTION MARKING ON THE HOIST CONTROL DEVICE ACTIVATED.

TEST

WARNING

DO NOT ATTEMPT TO CORRECT AN IMPROPERLY PHASED HOIST BY CHANGING ANY WIRING IN THE HOIST CONTROL DEVICE OR AT THE HOIST CONTACTORS; OR BY CHANGING THE MARKINGS ON THE HOIST CONTROL DEVICE.

To correct hoist motor phasing:

DANGER

- a. DISCONNECT POWER AND LOCKOUT DISCONNECTING MEANS BEFORE RECONNECTING (REVERSING) POWER LINES TO HOIST.
 - b. Only a qualified electrician should reconnect the power lines to the hoist.
 - c. Interchange any two lines supplying power to the hoist.
 - d. Re-energize power supply to the hoist.
 - e. Re-check hoist travel for correct hook motion. If direction of hook travel agrees with the direction marking of the hoist control device activated (i.e., hook direction is UP when the hoist UP control device is activated), hoist motor is properly phased and proceed to step 5. If the direction of hook travel does not agree with the direction marking of the hoist control device activated (i.e., hook direction is DOWN when the hoist UP control device is activated), hoist motor is improperly phased and must be corrected by repeating steps a through e.
2. If hoist has a motorized trolley, check trolley travel motion for agreement with the direction marking of the trolley control device.

To check trolley motion direction or trolley motor phasing:

MOMENTARILY activate one button or lever of the trolley control device and observe the direction of trolley motion. If direction of trolley travel agrees with the direction marking of the trolley control device activated (i.e., trolley direction is EAST when the trolley EAST control device is activated), trolley motor is properly phased. If the direction of trolley travel does not agree with the direction marking of the trolley control device activated (i.e., trolley direction is RIGHT when the trolley LEFT control device is activated), trolley motor is improperly phased and must be corrected. DO NOT USE TROLLEY until motor phasing is corrected.

WARNING

DO NOT OPERATE TROLLEY IF DIRECTION OF TROLLEY MOTION DOES NOT AGREE WITH THE DIRECTION MARKING ON THE TROLLEY CONTROL DEVICE ACTIVATED.

WARNING

DO NOT ATTEMPT TO CORRECT AN IMPROPERLY PHASED TROLLEY BY CHANGING ANY WIRING IN THE TROLLEY CONTROL DEVICE OR AT THE TROLLEY CONTACTORS; OR BY CHANGING THE MARKINGS ON THE TROLLEY CONTROL DEVICE.

TEST

To correct trolley motor phasing:



- a. **DISCONNECT POWER AND LOCKOUT DISCONNECTING MEANS BEFORE RECONNECTING (REVERSING) POWER LINES TO TROLLEY.**
 - b. Only a qualified electrician should reconnect the power lines to the trolley.
 - c. Interchange any two lines supplying power to the trolley motor only. **DO NOT** reverse main power leads to the hoist as this will also effect the phasing of the hoist motor.
 - d. Re-energize power supply to the hoist.
 - e. Re-check trolley travel for correct trolley motion. If direction of trolley travel agrees with the direction marking of the trolley control device activated (i.e., trolley direction is LEFT when the trolley LEFT control device is activated), trolley motor is properly phased. If the direction of trolley travel does not agree with the direction marking of the trolley control device activated (i.e., trolley direction is RIGHT when the trolley LEFT control device is activated), trolley motor is improperly phased and must be corrected by repeating steps a through e.
3. Operate hoist in the raising and lowering direction, without load on the hook, and stop motion to check operation of the motor brake. The drift of the hook should not exceed one inch in either direction. If hook drift exceeds one inch, the motor brake requires adjustment. Refer to the MOTOR BRAKE section of this manual for instructions on motor brake adjustment.
 4. Check operation of limit switches as follows:
 - a. All checking of limit switches should be accomplished without a load on the hook. All checking of limit switches should be accomplished by using the low speed of multiple-speed hoists, or inched into the limit if the hoist is a single-speed unit.



DISCONNECT POWER AND LOCKOUT DISCONNECTING MEANS BEFORE ADJUSTING LIMIT SWITCHES. LIMIT SWITCHES SHOULD BE ADJUSTED USING A CONTINUITY TESTER OR OTHER TYPE OF TESTER THAT WILL INDICATE OPEN OR CLOSED CIRCUITS WITHOUT THE NEED OF ELECTRICAL POWER.

Only a qualified electrician should adjust switches.

- b. Hoists with the standard gravity type upper limit switch:
 - (1) Check the gravity type upper limit switch by operating the hoist in the lifting direction. While the load block is raising, lift the weight of the upper gravity type limit switch manually until motion of the load block stops. Lifting the weight higher should cause the load block to lower until the weight is released. If raising motion does not stop when the weight is lifted, STOP hoist motion as the upper gravity limit switch requires adjustment or replacement. The lowering motion achieved by lifting the weight after raising motion of the load block has stopped is a reverse plugging feature to minimize the possibility of the load block striking the hoist frame or drum if the motor brake is out of adjustment. If adjustment of the gravity type upper limit switch is required, refer to the LIMIT SWITCHES section of this manual.
 - (2) Operate hoist in the lifting direction to a point where the block is about 12 inches below the hoist drum. If the hoist has more than one speed, continue to raise at low speed or; if hoist is a single-speed unit, inch the load block in the lifting direction until motion of the load block stops to check that load block stops when striking the weight of the gravity upper limit switch before striking any other part of the hoist. If the load block will hit any part of the hoist prior to striking the weight of the gravity type limit switch, STOP hoist motion as the upper gravity limit switch requires adjustment or replacement. If adjustment of the gravity type upper limit device is required, refer to the LIMIT SWITCHES section of this manual.

TEST

- (3) Operate the hoist in the lowering direction until the load block reaches its lowest point of travel. At this location of the load block two wraps of wire rope must remain at each anchorage on the hoist drum. **IF LESS THAN TWO WRAPS REMAIN AT EACH ANCHORAGE ON THE DRUM, DO NOT USE THE HOIST AT THIS LOCATION.** Contact Acco Material Handling Solutions or the distributor of the hoist.
- c. If a geared limit switch is specified and furnished on the hoist, operate hoist in the lowering direction until motion of the load block stops to check lower geared limit device circuit. While lowering the load block, watch the wire rope paying off the drum. If all the wire rope will pay off the drum before the lower geared limit device stops load block motion, STOP hoist motion as the lower geared limit device requires adjustment. The hoist lower geared limit device is set at the factory to stop lower travel of the load block with two wraps of wire rope remaining at each anchorage on the drum. ASME B30.16 allows one wrap of wire rope remaining at each anchorage on the drum when a lower limit device is used. It is recommended that the lower geared limit device be set to prevent the load block from resting on the floor and allowing the hoisting ropes to go slack. If adjustment of the lower geared limit device is required, refer to the LIMIT SWITCHES section of this manual.
- d. If a geared limit switch is specified and furnished on the hoist, operate hoist in the raising direction to a point where the block is about 12 inches below the hoist drum. If the hoist has more than one speed, continue to raise at low speed or; if hoist is a single-speed unit, inch the load block in the raising direction until motion of the load block stops to check upper geared limit switch circuit. If the load block will hit the weight of the gravity type upper limit switch before the upper geared limit device stops load block motion, STOP hoist motion as the upper geared limit device requires adjustment. The hoist upper geared limit device is set at the factory to stop upper hook travel when the top of the load block is two inches below the weight of the gravity type limit switch. If adjustment of the upper geared limit device is required, refer to the LIMIT SWITCHES section of this manual.

WARNING

GEARED UPPER LIMIT DEVICE MUST BE ADJUSTED SO THAT WHEN IT IS TRIPPED, THERE IS A MINIMUM OF 2 INCHES BETWEEN THE TOP OF THE LOAD BLOCK AND THE GRAVITY TYPE UPPER LIMIT SWITCH

WARNING

NEVER OPERATE HOIST WITHOUT THE PROTECTION OF PROPERLY FUNCTIONING LIMIT SWITCHES.

LOAD TEST:

All hoists in which load suspension parts have been altered, replaced, or repaired SHALL be dynamically tested by the owner/user before being placed in operational service. The load test shall be conducted under the direction of a designated person and a record of the test should be made. The test load applied to the hoist shall be at least equal to the rated load capacity of the hoist, or greater as approved by the hoist manufacturer. Functions to be performed during the load test include: (1) operation of control devices; (2) lifting and lowering; and (3) operation of brakes.

Load test steps are as follows:

1. Attach test load to the hoist hook. Test load shall be at least equal to the rated load capacity of the hoist. Acco will authorize the use of a hoist test load equal to 125% of the rated load capacity of the hoist for load test purposes only.
2. Before lifting the load, operate the hoist in the lifting direction to take any slack out of the hoist wire rope.

TEST

3. Lift the load a few inches and stop the hoist. If brakes stop and hold the load, continue lifting and lowering the load several feet, stopping the hoist several times in each direction to check that the hoist braking system stops and holds the load.
4. If the hoist braking system stops and holds the load, the hoist operates in accordance with the control devices, and no unusual sounds are present during operation, the hoist is ready to be released for operating purposes.
5. If the hoist braking system does not stop and hold the load, the hoist does not operate in accordance with the control devices, or any unusual sounds are present during operation, the hoist is not ready to be released for operating purposes; and corrective action must be taken.

MAINTENANCE AND REPAIR

If maintenance, adjustment, replacement of parts, or repair of the hoist is required because of any damage or malfunctions noted during the daily, frequent, or periodic inspections outlined in the INSPECTION section of this manual; because of conditions found during a hoist test as outlined in the TEST section of this manual; or based upon specific instructions outlined in other sections of this manual; the hoist shall be taken out of service, and maintenance performed as required.

WARNING

BEFORE PERFORMING ANY MAINTENANCE OR ADJUSTMENTS ON THE HOIST, REFER TO THE MAINTENANCE AND INSPECTION PROCEDURES SECTION OF THIS MANUAL.

DANGER

HAZARDOUS VOLTAGES ARE PRESENT IN THE CONTROL BOX, OTHER ELECTRICAL COMPONENTS, AND CONNECTIONS BETWEEN THESE COMPONENTS.

The main switch (disconnect) of the hoist, crane, or lifting system shall be de-energized. Lock and tag the main switch in the de-energized position in accordance with ANSI Z244.1.

CAUTION

DO NOT USE COTTER PINS, GROOVE PINS, OR LOCKNUTS THAT HAVE BEEN REMOVED DURING DISASSEMBLY. THEY MAY BE DAMAGED DURING REMOVAL AND WILL NOT FUNCTION PROPERLY IF REUSED. ALWAYS INSTALL COMPONENTS USING NEW COTTER PINS, GROOVE PINS, OR LOCKNUTS.

Follow the instructions outlined in various sections of this manual for specific components or portions of the hoist where maintenance or adjustment is required. Refer to the parts identification pages for the specific portion of the hoist where maintenance or adjustment is being performed and to identify any part numbers requiring replacement.

If any instructions are not clear; or if any additional information is required in reference to adjustment, maintenance, or identification of parts; contact Acco Material Handling Solutions or the distributor of the hoist.

LUBRICATION

All moving parts of the hoist or trolley for which lubrication is specified should be inspected, checked, and lubricated on a regular basis. The method used to deliver lubricant should be checked for proper delivery of the lubricant. This section applies to the hoist and trolley only. If the hoist is installed as part of a crane or as part of a lifting system, lubrication instructions covered in the manual furnished by the crane or lifting system manufacturer should be followed.

Hoist and trolley drive unit gear housings are enclosed and provide a liberal oil reservoir from which gears and bearings inside the housing are splash-lubricated. Check oil level in gear housings periodically, with intervals determined by use and operating conditions. Refer to INSPECTION section of this manual.

Hoist and trolley machinery shall be stationary when inspecting, checking, adding or changing lubricants. The main switch (disconnect) of the hoist, crane, or lifting system shall be de-energized. Lock and tag the main switch in the de-energized position in accordance with ANSI Z244.1.

WARNING

BEFORE INSPECTING, CHECKING, ADDING, OR CHANGING LUBRICANTS OF THE HOIST OR TROLLEY, REFER TO THE MAINTENANCE AND INSPECTION PROCEDURES SECTION OF THIS MANUAL.

CAUTION

DO NOT USE LUBRICANTS THAT DO NOT MEET THE SPECIFICATIONS OF THE RECOMMENDED LUBRICANTS.

WARNING

NEVER USE GEAR OILS IN THE HOIST GEAR HOUSINGS IF THEY CONTAIN ADDITIVES FOR FRICTION REDUCTION. GEAR OILS THAT CONTAIN FRICTION REDUCTION ADDITIVES WILL EFFECT THE OPERATION OF THE LOAD BRAKE, AND COULD RENDER THE LOAD BRAKE INOPERATIVE. FOR EXAMPLE, DO NOT USE WORM GEAR OILS IN HOIST GEAR HOUSINGS.

WARNING

ALL LUBRICANTS:
MAY CAUSE MILD EYE IRRITATION - AVOID CONTACT WITH EYES.
MAY CAUSE MODERATE SKIN IRRITATION - AVOID PROLONGED OR REPEATED CONTACT WITH SKIN. WASH THOROUGHLY AFTER HANDLING.
ARE SLIGHTLY COMBUSTIBLE - KEEP AWAY FROM EXTREME HEAT AND OPEN FLAME.

LUBRICATION

HOIST GEAR HOUSING:

The gear housing contains the oil fill hole and breather plug, oil level hole and plug, and oil drain hole and plug as shown in Figure 2.

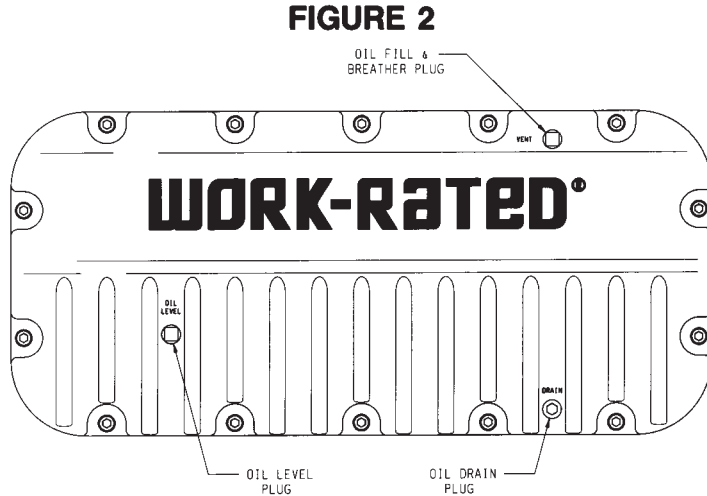

Product Series	Approximate Gear Housing Oil Capacity (Quart)
32	9 1/2
33	16
34	25
35	29

When the hoist is shipped from the factory, the oil fill hole is closed by use of a breather plug. When the breather plug is removed to add oil, it must be re-installed with the breather hole on one side of the square head on the outside of the plug directed upward. During hoist inspection, clean the breather plug and check that the breather hole in the plug is not closed because of foreign matter or dirt. If the breather hole is closed, either clean the plug to open the breather hole or replace with a new breather plug.

The oil level plug is a clear plastic plug that should allow the level of the oil inside the housing to be viewed through the plug. If the oil level cannot be viewed through the oil level plug, check oil level by removing the oil level plug and checking the oil level. The level of the oil in the housing should be level with the bottom of the oil level hole. If the level of the oil in the housing is below this point, add oil. Add oil through the oil fill hole until oil level in the housing is level with the bottom of the oil level hole or as noted through the clear oil level plug. Refer to Table 3 for recommended lubricants. AGMA stands for American Gear Manufacturers Association. Table 5 lists lubricants of some lubricant manufacturers in accordance with AGMA lubricant numbers.

**TABLE 3
HOIST GEAR HOUSING LUBRICANTS**

AMBIENT TEMPERATURE	AGMA LUBRICANT
Below 15° F (-9° C)	Contact Acco
15° to 60° F (-9° to 16° C)	AGMA No. 4 EP
50° to 125° F (10° to 52° C)	AGMA No. 6 EP
Above 100° F (38° C)	Contact Acco

Based on Mineral Oil which is standard.

For normal service, replace hoist gear housing gear oil after 300 operational hours or 6 months, whichever comes first. Replace oil more frequently for heavy duty service or as required. Select lubricant from Table 3. The hoist is shipped from the factory with AGMA No. 6 EP oil. Remove oil from housing through the drain hole and replace plug. Add oil through the oil fill hole until oil level in the housing is level with the bottom of the oil level hole or as noted through the clear oil level plug. Make sure all plugs have been replaced before operating hoist.

LUBRICATION

TROLLEY GEAR HOUSING (RIGHT-ANGLE WORM GEAR REDUCER UNIT):

The location of the breather plug, oil level plug, and drain plugs on the gear housing of the right-angle worm gear reducer unit are shown in Figure 3. Note that the trolley drive unit can be assembled or mounted with the motor input shaft either above or below the output shaft of the unit. The location of the motor determines which plugs are identified as breather, oil level, and drain. Refer to the portion of Figure 3 that applies to the reducer assembly on the hoist and trolley.

FIGURE 3

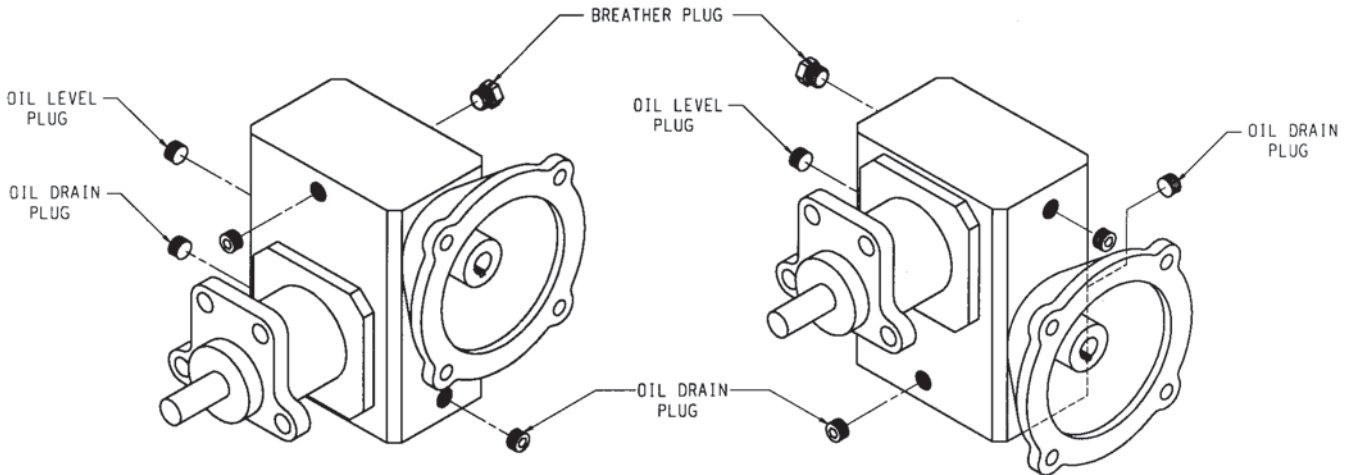

When the trolley is shipped from the factory, the breather plug hole is closed by use of a breather plug. If the breather plug is removed, it must be re-installed with the breather hole on the outside of the plug directed upward. During hoist and trolley inspection, clean the breather plug and check that the breather hole in the plug is not closed because of foreign matter or dirt. If the breather hole is closed, either clean the plug to open the breather hole or replace with a new breather plug.

The level of the oil in the housing should be level with the bottom of the oil level hole. If the level of the oil in the housing is below this point, add oil. Add oil through the oil fill hole at the breather plug until oil level in the housing is level with the bottom of the oil level hole. Refer to Table 4 for recommended lubricants. Capacity of the right-angle worm gear reducer unit housing is 1 pint (0.5 liter). AGMA stands for American Gear Manufacturers Association. Table 5 lists lubricants of some lubricant manufacturers in accordance with AGMA lubricant numbers.

**TABLE 4
TROLLEY GEAR HOUSING LUBRICANTS
RIGHT-ANGLE WORM REDUCER UNIT**

AMBIENT TEMPERATURE	AGMA LUBRICANT
Below 15° F (-9° C)	Contact Acco
15° to 60° F (-9° to 16° C)	AGMA No. 7 Comp.
50° to 125° F (10° to 52° C)	AGMA No. 8 Comp.
Above 100° F (38° C)	Contact Acco

Based on Mineral Oil which is standard pre 2017.

LUBRICATION

For Units shipped before 2017:

After original installation, the oil in the trolley right-angle worm gear reducer unit should be changed after 80 operational hours. Select lubricant from Table 4. The trolley is shipped from the factory with AGMA No. 8 Comp. oil. Remove oil from housing through the drain hole and replace plug. Add oil through the oil fill hole until oil level in the housing is level with the bottom of the oil level hole. Make sure all plugs have been replaced before operating trolley.

For normal service, replace trolley right-angle worm gear housing gear oil after 300 operational hours or 6 months, whichever comes first. Replace oil more frequently for heavy duty service or as required. Select lubricant from Table 4. The trolley is shipped from the factory with AGMA No. 8 Comp. oil. Remove oil from housing through the drain hole and replace plug. Add oil through the oil fill hole until oil level in the housing is level with the bottom of the oil level hole. Make sure all plugs have been replaced before operating trolley.

For Units shipped 2017 or later:

As of 2017, the trolley is shipped from the factory with AGMA No. 7 Comp. PAG (polyglycol) synthetic oil. The trolley gear housing nameplate will be stamped PAG460 to indicate the PAG synthetic oil was installed. The factory installed PAG synthetic oil should be changed only when performing maintenance that requires gear housing disassembly. PAG synthetic oil is not compatible with mineral oil or non-PAG synthetic oil. So, when changing or adding oil, do not use any oil other than PAG synthetic oil. See Table 5 for specific PAG synthetic oil installed at the factory.

**TABLE 5
AGMA LUBRICANTS BY MANUFACTURER**

MANUFACTURER	Hoist Gear Housings with Spur and Helical Gears		Trolley Gear Housings with Worm Gears		
	AGMA 4EP	AGMA 6EP	AGMA 7 Compound	AGMA 8 Compound	
AGMA Designation					
ISO Viscosity Grade	150	320	460	680	
MINERAL OIL	Amoco Oil Co.	Perma Gear EP 150	Perma Gear EP 320	Worm Gear Oil	Cylinder Oil 680
	ARCO	Pennant NL Oil 150	Pennant NL Oil 320	Modoc 175	Modoc 175
	Chevron USA, Inc.	Meropa 150	Meropa 320	Cylinder Oil W460	Cylinder Oil W680
	Conoco Inc.	Extra Duty 150 Gear Lube	Extra Duty 320 Gear Lube	Compounded Gear Oil 460	Compounded Gear Oil 680
	Exxon Co. USA	Spartan EP Grade 150	Spartan EP Grade 320	Cylestic TK-460	Cyiestic TK-680
	Gulf Oil Co.	EP Lubricant HD 150	EP Lubricant HD 320	Senate 460	Senate 680
	Mobil Oil Corp.	Mobilgear 600 XP 150	Mobilgear 600 XP 320	600W Super Cylinder Oil	Extra Hecla Super Cylinder Oil
	Shell Oil Co.	Omala 150	Omala 320	Valvata Oil J460	Valvata Oil J680
	Sun Oil Co.	Sun EP 150 Gear Oil	Sun EP 320 Gear Oil	Gear Oil C460	Gear Oil C680
	Texaco	Meropa 150	Meropa 320	Cylinder Oil W460	Cylinder Oil W680
	Ambient Temperature	15 to 60 F (-9 to 16 C)	50 to 125 F (10 to 52 C)	15 to 60 F (-9 to 16 C)	50 to 125 F (10 to 52 C)
SYNTHETIC OIL	Mobil Oil Corp.	N/A	Mobil SHC Gear 320	Glygoyle 460	N/A
	Ambient Temperature	N/A	-10 to 125 F (-20 to 52 C)	-10 to 120 F (-20 to 50 C)	N/A
	Note:	Not compatible with mineral oil. Optional at an additional price. Must specify on order.		This is a PAG (polyglycol) synthetic oil and is not compatible with mineral oil or non-PAG synthetic oil. Standard in Trolley Gear Housings with Worm Gears as of 2017. PAG460 is stamped on the gear housing name plate.	

LUBRICATION

BEARINGS:

Bearings not located inside gear housings are pre-lubricated and provided with shields or seals. This includes bearings located in the motor and sheaves. No additional lubrication is required.

HOOK THRUST BEARING:

For normal service, apply light machine oil to the thrust bearing that supports the load hook every 6 months. Apply oil more frequently for heavy duty service or as required.

EXPOSED OR OPEN GEARS AND PINIONS:

Exposed gears and pinions on trolleys are shipped from the factory without lubricant. Lyondell® EP Moly D Grease, packaged in a 4-ounce squeeze bottle container, is furnished with all hoists that have trolleys specified. During installation, the Lyondell® EP Moly D Grease should be applied to all exposed gears and pinions so that a coating of lubricant is on all pinion and gear teeth.

For normal service, apply Lyondell® EP Moly D Grease or equivalent to all exposed gears and pinions every 3 months to maintain a coating of lubricant on all pinion and gear teeth. Apply grease more frequently for heavy duty service or as required.

In applications where foreign matter or dirt combines with the grease on exposed gears and pinions, the dirty grease should be cleaned off the teeth prior to applying new grease.

Additional containers of Lyondell® EP Moly D Grease, packaged in a 4-ounce squeeze bottle, can be obtained by ordering Acco® part no. 69807.

WIRE ROPE:

Lubrication for wire rope operating over Polyamide sheaves is not recommended. Wire rope operating over steel sheaves should be maintained in a lubricated condition to reduce internal friction and prevent corrosion. Sections of rope located over sheaves or hidden during inspection and maintenance procedures require special attention when lubricant is applied. Wire rope should be lubricated with Crown Heavy-Duty Rope Lube or equivalent. Fitting on the loaded end of wire rope assemblies should be lubricated with Lubriplate 630-AA or 630-2.

For normal service, apply lubricant to wire rope and end fitting every 3 months. Apply lubricant more frequently for heavy duty service or as required.

In applications where foreign matter or dirt combines with the lubricant applied to the wire rope, the dirty lubricant should be cleaned off the rope prior to applying new lubricant.

LUBRICATION

UNIVERSAL JOINTS:

Universal joints on hoists are shipped from the factory with lubricant. The individual parts of universal joints should be well lubricated at all times. This allows the parts to easily oscillate or slide on each other.

Remove universal joint boots and lubricate universal joints by injecting Lyondell EP Moly D Grease or equivalent into the large pin via the lube fitting in the end of the pin. Grease should also be applied to the external surfaces of the center block and the pins (especially where they engage the forks). If a grease gun is not available, the universal joint should be disassembled and the contact surfaces of the pins, center block and forks should be greased. After reassembly of joints, reinstall boots. See pages 83 through 86 for depiction of parts and assembly and disassembly instructions.

For normal service, apply lubricant to universal joints every 3 months. Apply lubricant more frequently for heavy duty service or as required.

The universal joint boot should keep foreign matter or dirt away from the grease. If for some reason the grease has become contaminated, the dirty grease should be cleaned out of the universal joints prior to applying new grease.

Containers of Lyondell EP Moly D Grease, packaged in a 4-ounce squeeze bottle, can be obtained by ordering Acco part number 69807.

REASSEMBLY:

When hoist or trolley is disassembled for overhaul or major repair, apply Lubriplate 630-AA or 630-2 to the following during reassembly:

1. On the spline teeth of the spline connection between the drum and output shaft of the hoist gear housing.
2. Inside the bores of the coupling or universal joints connecting the motor shaft to the input shaft of the hoist gear housing or the input shaft of the trolley gear housing.

WARNING

NEVER APPLY ANY LUBRICANTS TO PARTS OF THE HOIST OR TROLLEY MOTOR BRAKE.

HOOKS

Load hooks on hoists in regular service should be visually inspected daily by the operator. If the hoist is used in multiple shift operations, load hooks should be visually inspected by the operator at the start of each shift. When visual inspection indicates that a more detailed inspection is required, follow the procedure outlined below. This procedure also applies to scheduled frequent and periodic inspections.

1. Measure hook throat opening from metal to metal of the hook as shown by dimension E in Figure 5. DO NOT measure from latch to metal. Hook must be replaced when throat opening measurement has increased 5%, not to exceed 1/4 inch, over the original throat opening dimension of a new hook. Refer to Table 7 for original dimensions and replacement dimensions for throat openings of standard hooks specified for the WORK-RATED® hoist line. To aid in measuring the throat opening, it is recommended the hoist owner/user make a gage of the dimensions shown in Table 7. This will allow quick measurement of the throat opening and immediate indication that hook replacement is required.

When WORK-RATED® hoists are specified with special hooks not covered in Table 7, the hook throat opening should be measured by the owner/user prior to installing the hoist. This will establish a reference point to use in future inspections for determination when the throat opening dimension has increased 5%, not to exceed 1/4 inch, requiring hook replacement. A gage similar to the one discussed above is recommended. The gage should have the throat opening dimension measured prior to installation, and a dimension 5%, not to exceed 1/4 inch, greater than the throat opening dimension measured prior to installation.

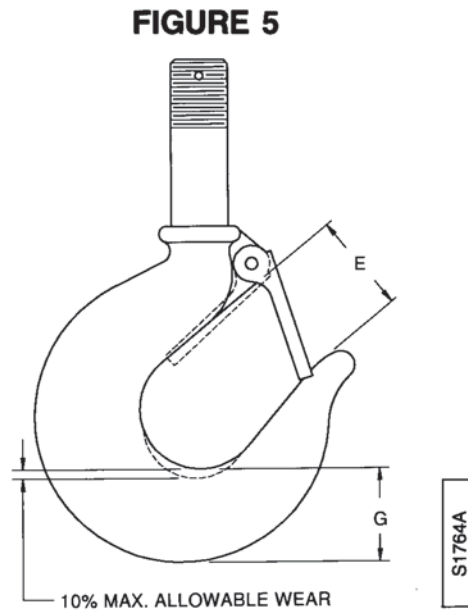

2. Measure hook depth at load bearing point (base, bowl, or saddle) of the hook as shown by dimension G in Figure 5. Hook must be replaced when wear at load bearing point is 10% of the original depth of the hook load bearing point. Refer to Table 8 for original dimensions and replacement dimensions for depth at load bearing point of standard hooks specified for the WORK-RATED® hoist line.

When WORK-RATED® hoists are specified with special hooks not covered in Table 8, the hook depth at load bearing point should be measured by the owner/user prior to installing the hoist. This will establish a reference point to use in future inspections for determination when wear at the load bearing point has reached 10% requiring hook replacement.

3. Any bend or twist of the hook from the plane of the unbent hook requires replacement of the hook.
4. A hook latch, when required, that is missing shall be replaced.
5. A hook latch, when required, that is inoperative shall be repaired or replaced.

HOOKS

**TABLE 7
HOOK THROAT OPENING DIMENSIONS
FIGURE 5, DIMENSION E
WORK—RATED® HOIST STANDARD HOOKS**

ROPE DIA.	REEVING	MAX. CAP. TONS	HOOK TYPE	HOOK PART NO.	NEW HOOK DIM. E	REPLACE HOOK DIM. E		
3/8	2PS	3	Steel Latch Type	69324	1.50	1.58		
				70891 (a)	1.50	1.58		
3/8	2PS	3	Bullard Gate Type	69326	1.50	1.58		
3/8	2PS	3	Bronze Latch Type	69548	1.88	1.98		
				70899 (a)	1.78	1.87		
3/8 1/2	2PD 2PS	5	Steel Latch Type	41732	1.88	1.98		
				70892 (a)	1.78	1.87		
3/8 1/2	2PD 2PS	5	Bullard Gate Type	41794	1.88	1.98		
3/8 1/2	2PD 2PS	5	Bronze Latch Type	42643	2.25	2.36		
				70900 (a)	2.41	2.53		
3/8 1/2 1/2 5/8 3/4	4PD 2PD 4PS 2PS 2PS	10 10 10 7.5 10	Steel Latch Type	58012	2.25	2.36		
				70893 (a)	2.41	2.53		
					58013	2.50	2.62	
						2.41	2.53	
3/8 1/2 1/2 5/8 3/4	4PD 2PD 4PS 2PS 2PS	10 10 10 7.5 10	Bullard Gate Type	58014	3.38	3.55		
					70901 (a)	3.41	3.58	
						43518	2.50	2.62
							70943 (a)	2.62
5/8	4PS	15	Steel Latch Type	59824	3.38	3.55		
1/2 3/4	4PD 4PS	20	Steel Latch Type	43577	3.38	3.55		
				70944 (a)	3.41	3.58		
1/2	4PD	20	Bullard Gate Type	71074	4.00	4.20		
3/4	4PS	20		71073	4.00	4.20		
9/16	4PD	25	Steel Latch Type	71213	4.00	4.20		
9/16	4PD	25	Bullard Gate Type	71214	4.00	4.20		

NOTE: (a) These are Spring Latch Hooks with a hole in the tip of the hook. Other listed Spring Latch Hooks do not have a hole in the tip of the hook. See paragraph 9 on page 41.

HOOKS

**TABLE 8
HOOK DEPTH DIMENSIONS AT LOAD POINT
FIGURE 5, DIMENSION G
WORK—RATED® HOIST STANDARD HOOKS**

ROPE DIA.	REEVING	MAX. CAP. TONS	HOOK TYPE	HOOK PART NO.	NEW HOOK DIM. G	REPLACE HOOK DIM. G
3/8	2PS	3	Steel Latch Type	69324	1.44	1.28
				70891 (a)	1.44	1.28
3/8	2PS	3	Bullard Gate Type	69326	1.44	1.28
3/8	2PS	3	Bronze Latch Type	69548	1.81	1.62
				70899 (a)	1.81	1.62
3/8 1/2	2PD 2PS	5	Steel Latch Type	41732	1.81	1.62
				70892 (a)	1.81	1.62
3/8 1/2	2PD 2PS	5	Bullard Gate Type	41794	1.81	1.62
3/8 1/2	2PD 2PS	5	Bronze Latch Type	42643	2.25	2.00
				70900 (a)	2.25	2.00
3/8 1/2 1/2 5/8 3/4	4PD 2PD 4PS 2PS 2PS	10	Steel Latch Type	58012	2.25	2.00
		10				
		10				
		7.5				
		10				
3/8 1/2 1/2 5/8 3/4	4PD 2PD 4PS 2PS 2PS	10	Bullard Gate Type	58013	2.59	2.33
		10				
		10				
		7.5				
		10				
3/8 1/2 1/2 5/8 3/4	4PD 2PD 4PS 2PS 2PS	10	Bronze Latch Type	58014	3.00	2.70
		10				
		10				
		7.5				
		10				
5/8	4PS	15	Steel Latch Type	43518	2.59	2.33
				70943 (a)	2.59	2.33
5/8	4PS	15	Bullard Gate Type	59824	3.00	2.70
1/2 3/4	4PD 4PS	20	Steel Latch Type	43577	3.00	2.70
				70944 (a)	3.00	2.70
1/2	4PD	20	Bullard Gate Type	71074	3.62	3.26
3/4	4PS	20		71073	3.62	3.26
9/16	4PD	25	Steel Latch Type	71213	3.62	3.26
9/16	4PD	25	Bullard Gate Type	71214	3.62	3.26

NOTE: (a) These are Spring Latch Hooks with a hole in the tip of the hook. Other listed Spring Latch Hooks do not have a hole in the tip of the hook. See paragraph 9 on page 41.

HOOKS

6. A hook with a hook latch that does not close the throat opening of the hook shall be removed from service or moused until the latch is replaced or repaired.
7. Hooks having damage from chemicals, corrosion, or deformation shall be repaired or replaced. Damage in the form of cracks, nicks, and gouges may be repaired by a designated person by grinding longitudinally, following the contour of the hook, provided no dimension of the hook is reduced by more than 10% of the original dimension of a new hook. If the repair reduces the dimension of the hook by more than 10% of the original dimension of a new hook, the hook shall be replaced.

NOTICE

ANY HOOK THAT REQUIRES REPLACEMENT BECAUSE OF EXCESSIVE BENDS, TWISTS, OR THROAT OPENING INDICATES ABUSE OR OVERLOADING OF THE HOIST. THEREFORE, OTHER LOAD-SUPPORTING COMPONENTS OF THE HOIST SHOULD BE INSPECTED FOR POSSIBLE DAMAGE WHEN SUCH CONDITIONS ARE FOUND.

⚠ CAUTION

NEVER REPAIR HOOKS BY WELDING OR RESHAPING. HEAT APPLIED TO THE HOOK WILL ALTER THE ORIGINAL HEAT TREATMENT OF THE HOOK MATERIAL AND REDUCE THE STRENGTH OF THE HOOK.

⚠ CAUTION

NEVER WELD HANDLES OR OTHER ATTACHMENTS TO THE HOOK. HEAT APPLIED TO THE HOOK WILL ALTER THE ORIGINAL HEAT TREATMENT OF THE HOOK MATERIAL AND REDUCE THE STRENGTH OF THE HOOK. IF HANDLES OR OTHER ATTACHMENTS ARE REQUIRED ON THE HOOK, CONTACT ACCO OR THE DISTRIBUTOR OF THE HOIST.

8. When replacing a hook, do not use the cotter pin that was removed from the hook nut. ALWAYS use a new cotter pin.

⚠ CAUTION

DO NOT USE COTTER PINS, GROOVE PINS, OR LOCKNUTS THAT HAVE BEEN REMOVED DURING DISASSEMBLY. THEY MAY BE DAMAGED DURING REMOVAL AND WILL NOT FUNCTION PROPERLY IF REUSED. ALWAYS INSTALL HOOK NUTS USING NEW COTTER PINS.

9. Previous style Spring Latch Hooks (up to and including 20 tons capacity) were phased out by Acco's supplier. The current style Spring Latch Hooks (up to and including 20 tons capacity) have a hole in the tip of the hook. This hole allows the addition of a cotter pin to prevent the latch from opening. Cotter pin is not supplied by Acco. Current style hooks are interchangeable with old style hooks, but current style hooks have a thicker cross section. Latches are not interchangeable between the two style hooks. Previous style hooks are no longer available. Latches for previous style hooks continue to be available. When ordering, identify whether or not hook has a hole in the tip and select part numbers accordingly from the applicable load block page in the applicable parts manual.

LIMIT SWITCHES

Complete WRIGHT® WORK-RATED® hoists are furnished standard with a gravity type upper limit switch. An optional geared limit switch will be furnished when specified in addition to the standard gravity upper limit switch. All limit switches must be operating and must be checked.

The optional geared type limit switch operates in relation to drum turns. If the wire rope does not track in the drum grooves or if the wire rope over wraps on the drum, the relationship between turns of the drum and turns of the upper geared limit device circuit become out of sequence; and the load block will travel up to the hoist frame and drum area of the hoist before the upper limit device circuit is activated. While the hoist should never be operated with the wire rope not seated in the drum grooves or with over wrapping of the wire rope on the drum, the gravity type limit switch is furnished with the optional geared limit switch in case such a situation occurs wherein the upper geared limit device becomes out of sequence with drum turns. For this reason, the optional geared upper limit device circuit must trip prior to the load block hitting the gravity-type limit switch weight. On hoists having both gravity and geared upper limit switches, the gravity limit switch must NEVER be deactivated or removed from the circuit.

The primary (gravity if it is the only limit switch furnished, or geared upper and lower if both gravity and geared furnished) limit switch on hoists in regular service should be checked without load on the hook by the operator at the start of each shift, or the first time the hoist is to be operated during each shift.

Both the primary (gravity if it is the only limit switch furnished, or geared upper and lower if both gravity and geared furnished), and the secondary (gravity upper if both gravity and geared furnished) limit switches are to be checked during scheduled frequent and periodic inspections.

WARNING

ALL CHECKING OF LIMIT SWITCHES SHOULD BE ACCOMPLISHED WITHOUT A LOAD ON THE HOOK. ALL CHECKING OF LIMIT SWITCHES SHOULD BE ACCOMPLISHED BY USING THE LOW SPEED OF MULTIPLE-SPEED HOISTS, OR INCHED INTO THE LIMIT IF THE HOIST IS A SINGLE-SPEED UNIT.

DANGER

DISCONNECT POWER AND LOCKOUT DISCONNECTING MEANS BEFORE ADJUSTING LIMIT SWITCHES. LIMIT SWITCHES SHOULD BE ADJUSTED USING A CONTINUITY TESTER OR OTHER TYPE OF TESTER THAT WILL INDICATE OPEN OR CLOSED CIRCUITS WITHOUT THE NEED OF ELECTRICAL POWER.

Only a qualified electrician should adjust switches.

CHECK OPERATION - GRAVITY LIMIT SWITCH:

Check operation of gravity limit switch as follows:

1. Check the gravity type upper limit switch by operating the hoist in the lifting direction. While the load block is raising, lift the weight of the upper gravity type limit switch manually until motion of the load block stops. Lifting the weight higher should cause the load block to lower until the weight is released. If raising motion does not stop when the weight is lifted, STOP hoist motion as the upper gravity limit switch requires adjustment or replacement. The lowering motion achieved by lifting the weight after raising motion of the load block has stopped is a reverse plugging feature to minimize the possibility of the load block striking the hoist frame or drum if the motor brake is out of adjustment. If adjustment of the gravity type upper limit switch is required, refer to adjustment instructions outlined below.

LIMIT SWITCHES

2. Operate hoist in the lifting direction to a point where the block is about 12 inches below the hoist drum. If the hoist has more than one speed, continue to raise at low speed or; if hoist is a single-speed unit, inch the load block in the lifting direction until motion of the load block stops to check that load block stops when striking the weight of the gravity upper limit switch before striking any other part of the hoist. If the load block will hit any part of the hoist prior to striking the weight of the gravity type limit switch, STOP hoist motion as the upper gravity limit switch requires adjustment or replacement. If adjustment of the gravity type upper limit device is required, refer to adjustment instructions outlined below.
3. Operate the hoist in the lowering direction until the load block reaches its lowest point of travel. At this location of the load block two wraps of wire rope must remain at each anchorage on the hoist drum. IF LESS THAN TWO WRAPS REMAIN AT EACH ANCHORAGE ON THE DRUM, DO NOT USE THE HOIST AT THIS LOCATION. Contact Acco Material Handling Solutions or the distributor of the hoist.

WARNING

HOISTS THAT ARE LOCATED WHERE THE LOAD BLOCK CAN BE LOWERED INTO PITS OR LOWERED TO OTHER LEVELS BELOW THE OPERATING FLOOR LEVEL OF THE HOIST MUST HAVE A LOWER LIMIT SWITCH IN ACCORDANCE WITH ANSI B30.16. IF THE HOIST IS TO BE USED IN SUCH AN APPLICATION AND IT DOES NOT HAVE A LOWER LIMIT SWITCH, DO NOT USE THE HOIST; CONTACT ACCO MATERIAL HANDLING SOLUTIONS OR THE DISTRIBUTOR OF THE HOIST.

CHECK OPERATION - GEARED LIMIT SWITCH:

1. Operate hoist in the lowering direction until motion of the load block stops to check lower geared limit device circuit. While lowering the load block, watch the wire rope paying off the drum. If all the wire rope will pay off the drum before the lower geared limit device stops load block motion, STOP hoist motion as the lower geared limit device requires adjustment. The hoist lower geared limit device is set at the factory to stop lower travel of the load block with two wraps of wire rope remaining at each anchorage on the drum. ASME B30.16 allows one wrap of wire rope remaining at each anchorage on the drum when a lower limit device is used. It is recommended that the lower geared limit device be set to prevent the load block from resting on the floor and allowing the hoisting ropes to go slack. If adjustment of the lower geared limit device is required, refer to the adjustment instructions outlined below.
2. Operate hoist in the lifting direction to a point where the block is about 12 inches below the hoist drum. If the hoist has more than one speed, continue to raise at low speed or; if hoist is a single-speed unit, inch the load block in the lifting direction until motion of the load block stops to check upper geared limit switch circuit. If the load block will hit the weight of the gravity type limit switch before the upper geared limit device stops load block motion, STOP hoist motion as the upper geared limit device requires adjustment. The hoist upper geared limit device is set at the factory to stop upper hook travel when the top of the load block is two inches below the weight of the gravity type limit switch. If adjustment of the upper geared limit device is required, refer to the adjustment instructions outlined below.

WARNING

OPTIONAL GEARED UPPER LIMIT DEVICE MUST BE ADJUSTED SO THAT WHEN IT IS TRIPPED, THERE IS A MINIMUM OF 2 INCHES BETWEEN THE TOP OF THE LOAD BLOCK AND THE WEIGHT OF THE GRAVITY TYPE UPPER LIMIT SWITCH.

An optional hoist power-circuit limit switch is available when specified. A power circuit limit switch is checked in the same manner as the gravity type upper limit switch by manually lifting the limit switch tripping device while operating the hoist in the lifting direction.

LIMIT SWITCHES

⚠ WARNING

NEVER OPERATE HOIST WITHOUT THE PROTECTION OF PROPERLY FUNCTIONING LIMIT SWITCHES. HOIST LIMIT SWITCHES SHALL NOT BE USED AS A NORMAL MEANS OF STOPPING TRAVEL MOTION OR THE LOAD. THESE ARE EMERGENCY DEVICES ONLY.

THE PRIMARY UPPER AND LOWER LIMIT SWITCH SHOULD BE CHECKED WITHOUT LOAD ON THE HOOK AT THE START OF EACH SHIFT, OR THE FIRST TIME HOIST IS TO BE OPERATED DURING EACH SHIFT.

THESE INSTRUCTIONS APPLY TO LIMIT SWITCH ADJUSTMENT FOR AN UNLOADED LOAD BLOCK ONLY. LIMIT SWITCHES MUST BE ADJUSTED TO PREVENT THE LOAD BLOCK OR THE LOAD BEING LIFTED FROM COMING INTO CONTACT WITH ANY PART OF THE HOIST; OR THE CRANE, HOIST SUPPORT STRUCTURE, OR OTHER EQUIPMENT WHERE THE HOIST IS INSTALLED.

ADJUSTMENT - GRAVITY LIMIT SWITCH:

⚠ DANGER

DISCONNECT POWER AND LOCKOUT DISCONNECTING MEANS BEFORE ADJUSTING LIMIT SWITCHES. LIMIT SWITCHES SHOULD BE ADJUSTED USING A CONTINUITY TESTER OR OTHER TYPE OF TESTER THAT WILL INDICATE OPEN OR CLOSED CIRCUITS WITHOUT THE NEED OF ELECTRICAL POWER.

Only a qualified electrician should adjust switches.

The gravity type upper limit switch unit is mounted in a separate enclosure near the rope dead end on single reeved hoists, or near the equalizing sheave on double reeved hoists. Figure 6 shows the gravity limit switch unit enclosure and gravity-operated weight. Figure 7 shows the switch contact unit and operating cam located inside the gravity limit switch unit enclosure.

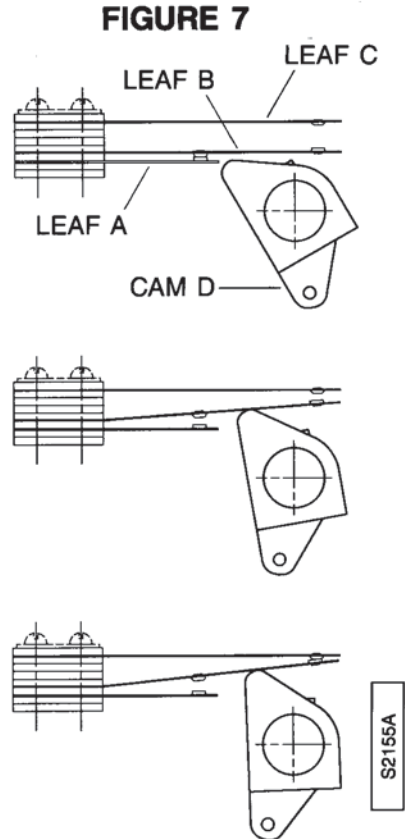
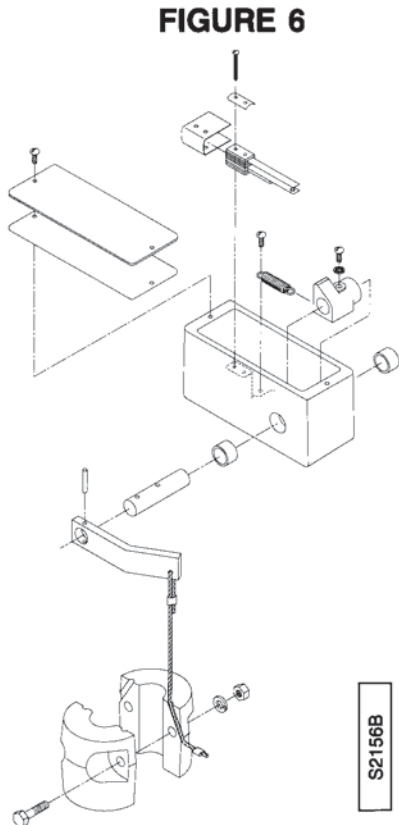

LIMIT SWITCHES

Adjust gravity limit switch as follows:

1. Disconnect power and lockout disconnecting means.
2. Referring to Figure 6, remove cover and gasket of the gravity limit switch enclosure by loosening and removing screws holding cover to housing.
3. Check that wires to leafs A, B, and C are connected.
4. Manually lift the gravity-operated weight and observe action of cam D opening the contacts on leafs A and B, and closing the contacts on leafs B and C by visual observation or with a continuity tester or other type of tester that will indicate open or closed circuits without the need of electrical power.

As gravity-operated weight is manually lifted, cam D should rotate against and lift leaf B, opening the lifting control circuit contacts on leafs A and B. Continuing the manual lifting of gravity-operated weight, cam D should continue to rotate against and lift leaf B, closing the control circuit reversing contacts on leafs B and C.

5. If contacts do not open and close properly, minor adjustment can be made to leafs A, B, or C by a slight bending of the leaf. If slight bending of the leafs does not correct the adjustment requirements, replace contact unit or the entire gravity limit switch unit.
6. After the gravity limit switch has been adjusted or replaced, the gravity limit switch should be rechecked in accordance with "CHECK OPERATION - GRAVITY LIMIT SWITCH" instructions.

OPTIONAL - GEARED LIMIT SWITCH:

When specified, a Wright® two-circuit geared limit switch or a commercial two-circuit or four-circuit geared rotary limit switch may be furnished on the hoist in addition to the gravity type limit switch. When specified, the Wright® geared limit switch or the commercial geared rotary limit switch is mounted in the enclosure at the drum end opposite the hoist gear reducer assembly.

ADJUSTMENT - WRIGHT® GEARED LIMIT SWITCH (WHEN SPECIFIED):



DISCONNECT POWER AND LOCKOUT DISCONNECTING MEANS BEFORE ADJUSTING LIMIT SWITCHES. LIMIT SWITCHES SHOULD BE ADJUSTED USING A CONTINUITY TESTER OR OTHER TYPE OF TESTER THAT WILL INDICATE OPEN OR CLOSED CIRCUITS WITHOUT THE NEED OF ELECTRICAL POWER.

Only a qualified electrician should adjust switches.

LIMIT SWITCHES

The WRIGHT® geared limit switch unit is mounted in the enclosure at the drum end opposite the hoist gear reducer assembly. Figure 8a illustrates the WRIGHT® geared limit switch unit. The lower limit is adjusted using limit gear (3) and limit switch (4) located at the right-hand end of the geared limit switch unit; and the upper limit is adjusted using limit gear (5) and limit switch (6) located at the left-hand end of the geared limit switch unit.

FIGURE 8a

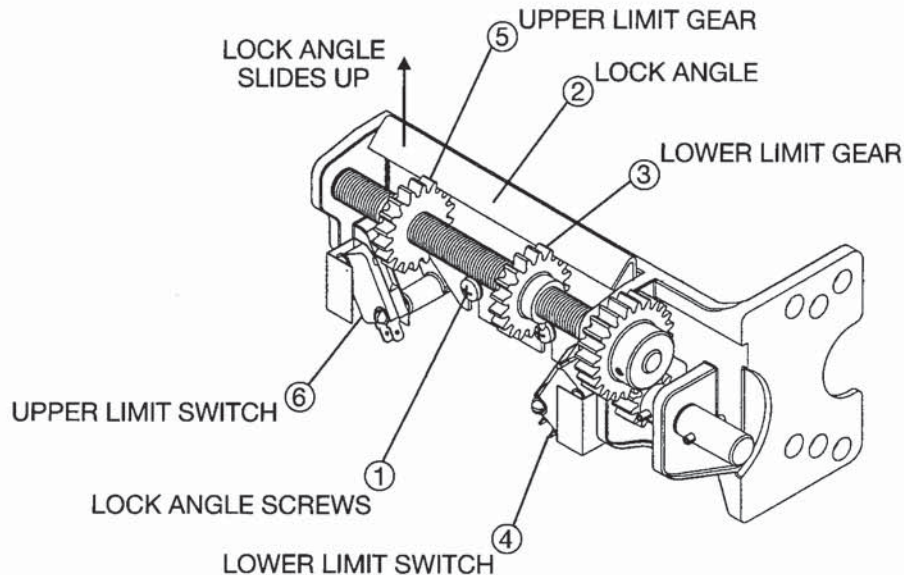

Adjust WRIGHT® geared limit switch as follows:

1. Disconnect power and lockout disconnecting means.
2. Remove the cover of the enclosure at the drum end opposite the hoist gear reducer assembly.
3. If the upper limit is to be set at a higher point than the current setting or the lower limit is to be set at a lower point than the current setting, the current settings must be deleted before adjustments are made as follows:
 - a. Loosen the two screws (1) holding the lock angle (2) to the limit switch housing until the lock angle (2) can be released from the limit gears (3 and 5).
 - b. Rotate upper limit gear (5) away from upper limit switch (6) and/or rotate lower limit gear (3) away from lower limit switch (4).
4. Adjust upper limit as follows:
 - a. Connect power to the hoist and operate hoist in the lifting direction until load block reaches position where upper limit is to operate. The minimum distance allowed between the top of the load block and the weight of the gravity type upper limit switch is two (2) inches.
 - b. Disconnect power and lockout disconnecting means before adjusting upper limit of geared limit switch.
 - c. Connect a continuity tester or other type of tester that will indicate open or closed circuits without the need of electrical power to upper limit switch (6).
 - d. Loosen the two screws (1) holding the lock angle (2) to the limit switch housing until the lock angle (2) can be released from the tooth spaces of the limit gears (3 and 5).
 - e. Rotate upper limit gear (5) toward upper limit switch (6) until the upper limit gear (5) actuates the upper limit switch (6) as indicated by the continuity tester.

LIMIT SWITCHES

- f. Position locking angle (2) in the tooth spaces of the limit gears (3 and 5). Secure locking angle in place using the two screws (1).
- g. Connect power to the hoist and operate hoist in the lifting direction to check operation of the geared upper limit switch. If geared upper limit switch does not operate at the desired position of the load block, repeat steps 4a through 4g.

WARNING

GEARED UPPER LIMIT DEVICE MUST BE ADJUSTED SO THAT WHEN IT IS TRIPPED, THERE IS A MINIMUM OF 2 INCHES BETWEEN THE TOP OF THE LOAD BLOCK AND THE WEIGHT OF THE GRAVITY TYPE UPPER LIMIT SWITCH.

5. Adjust lower limit as follows:

- a. Connect power to the hoist and operate hoist in the lowering direction until load block reaches position where lower limit is to operate. A minimum of one wrap of wire rope must remain at each anchorage on the drum.
- b. Disconnect power and lockout disconnecting means before adjusting lower limit of geared limit switch.
- c. Connect a continuity tester or other type of tester that will indicate open or closed circuits without the need of electrical power to lower limit switch (4).
- d. Loosen the two screws (1) holding the lock angle (2) to the limit switch housing until the lock angle (2) can be released from the tooth spaces of the limit gears (3 and 5).
- e. Rotate lower limit gear (3) toward lower limit switch (4) until the lower limit gear (3) actuates the lower limit switch (4) as indicated by the continuity tester.
- f. Position locking angle (2) in the tooth spaces of the limit gears (3 and 5). Secure locking angle in place using the two screws (1).
- g. Connect power to the hoist and operate hoist in the lowering direction to check operation of the geared lower limit switch. If geared lower limit switch does not operate at the desired position of the load block, repeat steps 5a through 5g.

WARNING

GEARED LOWER LIMIT DEVICE MUST BE ADJUSTED SO THAT WHEN IT IS TRIPPED, THERE IS A MINIMUM OF ONE WRAP OF WIRE ROPE REMAINING AT EACH ANCHORAGE ON THE DRUM.

6. After both the geared upper and lower limit devices have been adjusted, the geared limit switch should be rechecked in accordance with "CHECK OPERATION - GEARED LIMIT SWITCH" instructions.

CAUTION

AFTER ADJUSTING LIMIT SWITCHES, REPLACE AND TIGHTEN ALL LIMIT SWITCH ENCLOSURE COVERS BEFORE RETURNING THE HOIST TO REGULAR SERVICE.

LIMIT SWITCHES

ADJUSTMENT – GE® GEARED ROTARY LIMIT SWITCH (WHEN SPECIFIED):



DISCONNECT POWER AND LOCKOUT DISCONNECTING MEANS BEFORE ADJUSTING LIMIT SWITCHES. LIMIT SWITCHES SHOULD BE ADJUSTED USING A CONTINUITY TESTER OR OTHER TYPE OF TESTER THAT WILL INDICATE OPEN OR CLOSED CIRCUITS WITHOUT THE NEED OF ELECTRICAL POWER.

Only a qualified electrician should adjust switches.

The GE® geared rotary limit switch unit is mounted in the enclosure at the drum end opposite the hoist gear reducer assembly. Figure 8b is a diagram of the switch arrangement from the instructions on the inside of the cover on the enclosure of the GE® geared rotary limit switch unit.

FIGURE 8b

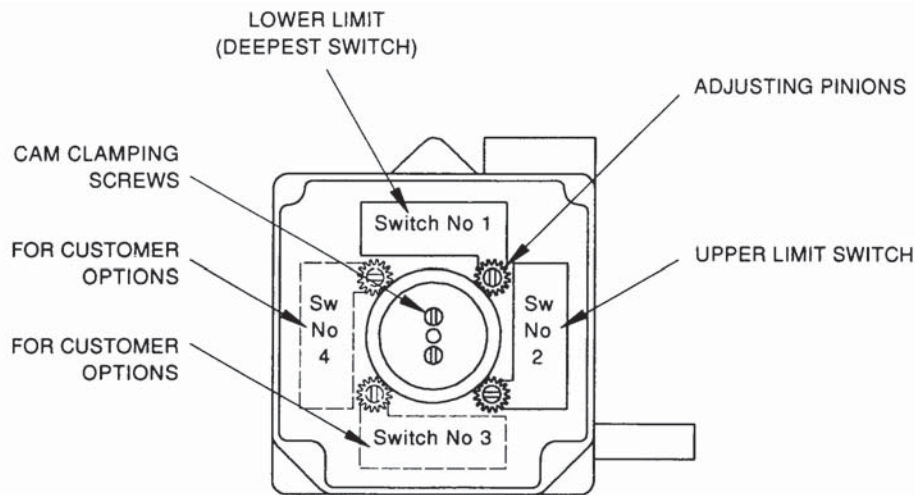

A two-circuit limit switch will have switches 1 and 2 as shown in Figure 8b. A four-circuit limit switch will have switches 1, 2, 3, and 4 as shown in Figure 8b. Switch no. 1 is the bottom or deepest switch in the enclosure and is operated by the bottom or deepest gear cam in the enclosure. Switch no. 1 is connected in the hoist control circuit to operate as the lower limit device. Switch no. 2 is the second switch from the bottom of the enclosure and is operated by the second gear cam from the bottom of the enclosure. Switch no. 2 is connected in the hoist control circuit to operate as the upper limit device. Switch no. 3 is the third switch from the bottom of the enclosure and is operated by the third gear cam from the bottom of the enclosure. Switch no. 3 is not connected in the hoist control circuit and is for the option of the owner/user. Switch no. 4 is the fourth switch from the bottom of the enclosure and is operated by the fourth gear cam from the bottom of the enclosure. Switch no. 4 is not connected in the hoist control circuit and is for the option of the owner/user.

Adjust GE® geared rotary limit switch as follows:

1. Disconnect power and lockout disconnecting means.
2. Remove the cover of the enclosure at the drum end opposite the hoist gear reducer assembly.
3. Remove the cover of the GE® geared rotary limit switch enclosure.
4. Adjust upper limit as follows:
 - a. Connect power to the hoist and operate hoist in the lifting direction until load block reaches position where upper limit is to operate. The minimum distance allowed between the top of the load block and the weight of the gravity type upper limit switch is two (2) inches.
 - b. Disconnect power and lockout disconnecting means before adjusting upper limit of geared rotary limit switch.
 - c. Connect a continuity tester or other type of tester that will indicate open or closed circuits without the need of electrical power to switch number 2.

LIMIT SWITCHES

- d. Loosen the two cam clamping screws on top of the cam assembly one-half turn each.
- e. Locate the adjusting pinion for cam no. 2 by referring to the indicating arrow on insulation shield.
- f. Depress adjusting pinion for cam no. 2 with a screwdriver until pinion teeth mesh with teeth of gear cam no. 2.
- g. Rotate cam in direction to operate switch no. 2.
- h. The white marker on the gear teeth is directly over the cam lobe that trips the switch. When the operating cam has been adjusted so the cam lobe has tripped the switch, the adjustment is complete. In addition to visual observation, a continuity tester or other type of tester that will indicate open or closed circuits without the need of electrical power can be connected to the switch.
- i. Re-tighten clamping screws.
- j. Connect power to the hoist and operate hoist in the lifting direction to check operation of the geared rotary upper limit switch. If geared rotary upper limit switch does not operate at the desired position of the load block, repeat steps 4a through 4j.

WARNING

GEARED UPPER LIMIT DEVICE MUST BE ADJUSTED SO THAT WHEN IT IS TRIPPED, THERE IS A MINIMUM OF 2 INCHES BETWEEN THE TOP OF THE LOAD BLOCK AND THE WEIGHT OF THE GRAVITY TYPE UPPER LIMIT SWITCH.

5. Adjust lower limit as follows:
 - a. Connect power to the hoist and operate hoist in the lowering direction until load block reaches position where lower limit is to operate. A minimum of one wrap of wire rope must remain at each anchorage on the drum.
 - b. Disconnect power and lockout disconnecting means before adjusting lower limit of geared rotary limit switch.
 - c. Connect a continuity tester or other type of tester that will indicate open or closed circuits without the need of electrical power to switch number 1.
 - d. Loosen the two cam clamping screws on top of the cam assembly one-half turn each.
 - e. Locate the adjusting pinion for cam no. 1 by referring to the indicating arrow on insulation shield.
 - f. Depress adjusting pinion for cam no. 1 with a screwdriver until pinion teeth mesh with teeth of gear cam no.1.
 - g. Rotate cam in direction to operate switch no. 1.
 - h. The white marker on the gear teeth is directly over the cam lobe that trips the switch. When the operating cam has been adjusted so the cam lobe has tripped the switch, the adjustment is complete. In addition to visual observation, a continuity tester or other type of tester that will indicate open or closed circuits without the need of electrical power can be connected to the switch.
 - i. Re-tighten clamping screws.
 - j. Connect power to the hoist and operate hoist in the lowering direction to check operation of the geared rotary lower limit switch. If geared rotary lower limit switch does not operate at the desired position of the load block, repeat steps 5a through 5j.

WARNING

GEARED LOWER LIMIT DEVICE MUST BE ADJUSTED SO THAT WHEN IT IS TRIPPED, THERE IS A MINIMUM OF ONE WRAP OF WIRE ROPE REMAINING AT EACH ANCHORAGE ON THE DRUM.

6. After both the geared upper and lower limit devices have been adjusted, the geared rotary limit switch should be rechecked in accordance with “CHECK OPERATION—GEARED LIMIT SWITCH” instructions.

CAUTION

AFTER ADJUSTING LIMIT SWITCHES, REPLACE AND TIGHTEN ALL LIMIT SWITCH ENCLOSURE COVERS BEFORE RETURNING THE HOIST TO REGULAR SERVICE.

LIMIT SWITCHES

ADJUSTMENT – HUBBELL® GEARED ROTARY LIMIT SWITCH (WHEN SPECIFIED):

⚡ DANGER

DISCONNECT POWER AND LOCKOUT DISCONNECTING MEANS BEFORE ADJUSTING LIMIT SWITCHES. LIMIT SWITCHES SHOULD BE ADJUSTED USING A CONTINUITY TESTER OR OTHER TYPE OF TESTER THAT WILL INDICATE OPEN OR CLOSED CIRCUITS WITHOUT THE NEED OF ELECTRICAL POWER.

Only a qualified electrician should adjust switches.

The HUBBELL® geared rotary limit switch unit is mounted in the enclosure at the drum end opposite the hoist gear reducer assembly. Figure 8c is a diagram of the switch arrangement.

FIGURE 8c

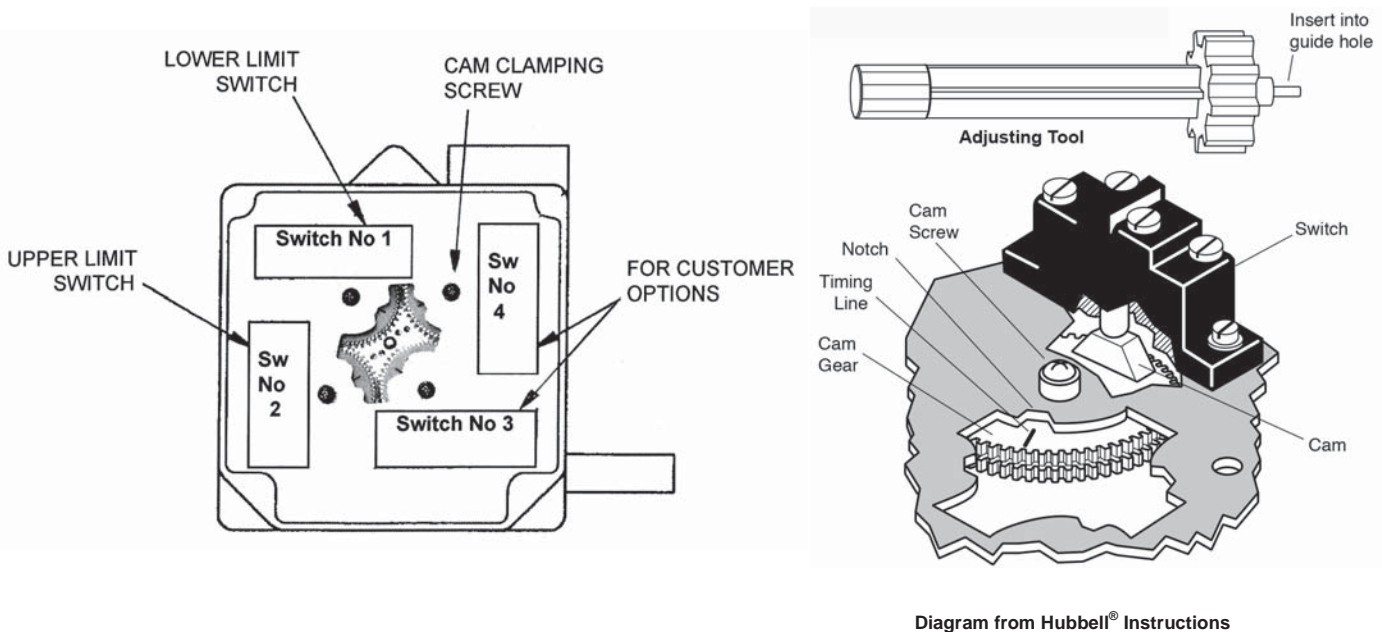

A two-circuit limit switch will have switches 1 and 2 as shown in Figure 8c. A four-circuit limit switch will have switches 1, 2, 3, and 4 as shown in Figure 8c. Switches are operated by the cam upon which they sit. Switch number 1 is connected in the hoist control circuit to operate as the lower limit device. Switch no. 2 is connected in the hoist control circuit to operate as the upper limit device. Switches number 3 and 4 are not connected in the hoist control circuit and are for the option of the owner/user.

Adjust HUBBELL® geared rotary limit switch as follows:

1. Disconnect power and lockout disconnecting means.
2. Remove the cover of the enclosure at the drum end opposite the hoist gear reducer assembly.
3. Remove the cover of the HUBBELL® geared rotary limit switch enclosure.
4. Adjust upper limit as follows:
 - a. Connect power to the hoist and operate hoist in the lifting direction until load block reaches position where upper limit is to operate. The minimum distance allowed between the top of the load block and the weight of the gravity type upper limit switch is two (2) inches.
 - b. Disconnect power and lockout disconnecting means before adjusting upper limit of geared rotary limit switch.
 - c. Connect a continuity tester or other type of tester that will indicate open or closed circuits without the need of electrical power to switch number 2.

LIMIT SWITCHES

- d. Loosen the screw for the cam which actuates switch number 2.
- e. Insert the included adjustment tool into the guide hole closest to cam number 2.
- f. Engage teeth on adjustment tool with teeth on cam number 2.
- g. Rotate cam in direction to operate switch number 2.
- h. The black line on the cam will appear in the notch. This will be the approximate position at which the switch will be actuated. When the operating cam has tripped the switch, the adjustment is complete. In addition to visual observation, a continuity tester or other type of tester that will indicate open or closed circuits without the need of electrical power can be connected to the switch.
- i. Re-tighten the screw for the cam. Avoid over-tightening which could damage screw and screw threads.
- j. Connect power to the hoist and operate hoist in the lifting direction to check operation of the geared rotary upper limit switch. If geared rotary upper limit switch does not operate at the desired position of the load block, repeat steps 4a through 4j.

WARNING

GEARED UPPER LIMIT DEVICE MUST BE ADJUSTED SO THAT WHEN IT IS TRIPPED, THERE IS A MINIMUM OF 2 INCHES BETWEEN THE TOP OF THE LOAD BLOCK AND THE WEIGHT OF THE GRAVITY TYPE UPPER LIMIT SWITCH.

5. Adjust lower limit as follows:
 - a. Connect power to the hoist and operate hoist in the lowering direction until load block reaches position where lower limit is to operate. A minimum of one wrap of wire rope must remain at each anchorage on the drum.
 - b. Disconnect power and lockout disconnecting means before adjusting lower limit of geared rotary limit switch.
 - c. Connect a continuity tester or other type of tester that will indicate open or closed circuits without the need of electrical power to switch number 1.
 - d. Loosen the screw for the cam which actuates switch number 1.
 - e. Insert the included adjustment tool into the guide hole closest to cam number 1.
 - f. Engage teeth on adjustment tool with teeth on cam number 1.
 - g. Rotate cam in direction to operate switch number 1.
 - h. The black line on the cam will appear in the notch. This will be the approximate position at which the switch will be actuated. When the operating cam has tripped the switch, the adjustment is complete. In addition to visual observation, a continuity tester or other type of tester that will indicate open or closed circuits without the need of electrical power can be connected to the switch.
 - i. Re-tighten the screw for the cam. Avoid over-tightening which could damage screw and screw threads.
 - j. Connect power to the hoist and operate hoist in the lowering direction to check operation of the geared rotary lower limit switch. If geared rotary lower limit switch does not operate at the desired position of the load block, repeat steps 5a through 5j.

WARNING

GEARED LOWER LIMIT DEVICE MUST BE ADJUSTED SO THAT WHEN IT IS TRIPPED, THERE IS A MINIMUM OF ONE WRAP OF WIRE ROPE REMAINING AT EACH ANCHORAGE ON THE DRUM.

6. After both the geared upper and lower limit devices have been adjusted, the geared rotary limit switch should be rechecked in accordance with “CHECK OPERATION—GEARED LIMIT SWITCH” instructions.

CAUTION

AFTER ADJUSTING LIMIT SWITCHES, REPLACE AND TIGHTEN ALL LIMIT SWITCH ENCLOSURE COVERS BEFORE RETURNING THE HOIST TO REGULAR SERVICE.

If other types of limit switches are specified, refer to instructions furnished with the switch unit or as additional pages with this manual for adjustment information.

MECHANICAL LOAD BRAKE

WRIGHT® WORK-RATED® hoists are furnished with a mechanical load brake specified as standard. The mechanical load brake is located in the hoist gear reducer housing. The mechanical load brake serves as a control braking means, and in conjunction with the hoist motor brake comprises the hoist braking system. When another type of control braking means is specified, the mechanical load brake will not be included with the hoist.

The hoist braking system on hoists in regular service should be checked without load on the hook by the operator at the start of each shift, or the first time the hoist is to be operated during each shift. The hoist braking system should be checked during scheduled frequent and periodic inspections.

The mechanical load brake is self-adjusting, and does not require any regular maintenance except as noted by daily, frequent, or periodic inspections.

During daily, frequent, or periodic inspections, the hoist braking system should be checked as follows:

1. Operate hoist in the lifting and lowering direction, without load on the hook, and stop motion to check operation of the hoist braking system. The drift of the hook should not exceed one inch in either direction. If hook drift exceeds one inch, the motor brake normally requires adjustment or lining replacement. Refer to the HOIST MOTOR BRAKE section of this manual for instructions on motor brake adjustment or lining replacement.
2. After completing hoist motor brake adjustment or lining replacement, operate hoist in the lifting and lowering direction, without load on the hook, and stop motion to check operation of the hoist braking system. If hook drift is still excessive, a test of the mechanical load brake should be conducted.
3. Procedure for testing the mechanical load brake is as follows:
 - a. Lock the motor brake in an open or disengaged position. To disengage hoist motor brake, refer to Figure 13 of the HOIST MOTOR BRAKE section of this manual, and lock armature plate (B) against magnet (A).
 - b. Attach a test load of 25% to 50% of hoist rated load capacity to the hoist hook.
 - c. Lift the test load a distance of six to eight inches. Hoist may hold test load or test load may drift back to floor. This step is to check if drift will occur and must be considered in future steps of the test. If hoist holds test load, the hoist mechanical load brake passes test. If drift occurs, proceed with test.
 - d. Lift test load several feet and stop motion. If hoist mechanical load brake holds test load, proceed to step e. If test load drifts downward, and lowering speed does not exceed normal specified lowering speed, hoist passes mechanical load brake test. If test load drifts downward, and lowering speed exceeds normal specified lowering speed; and speed and sound indicates test load is in free fall, depress lowering control and lower test load the remaining distance by use of the hoist motor. Mechanical load brake has failed test.
 - e. If hoist mechanical load brake held test load in step d., proceed as follows: Depress lowering control, and as soon as hoist has started to lower test load, release lowering control. If hoist stops and holds test load, the hoist mechanical load brake passes test. If test load drifts downward, proceed as outlined in step d.
 - f. If the mechanical load brake fails the test, disassembly of the gear reducer housing is required for adjustment or replacement of the ratchet unit of the mechanical load brake unit.



UNLOCK OR ENGAGE HOIST MOTOR BRAKE IN ITS NORMAL OPERATING CONDITION PRIOR TO PLACING THE HOIST BACK IN REGULAR SERVICE.

MECHANICAL LOAD BRAKE

- 9. If additional information about testing of the mechanical load brake is required, or if the procedure for testing the mechanical load brake is not clear, contact Acco Material Handling Solutions, York, Pennsylvania or the distributor of the hoist. Do not test the mechanical load brake unless this information is fully understood.

⚠ WARNING

DURING MECHANICAL LOAD BRAKE TEST, ALL PERSONNEL SHOULD BE ALERTED TO THE FACT THAT A FREE-FALL CONDITION OF THE TEST LOAD COULD BE EXPERIENCED. ALL PERSONNEL SHOULD BE POSITIONED AS FAR FROM THE PATH OF THE TEST LOAD AS POSSIBLE.

TO REPLACE RATCHET UNIT:

The hoist gear reducer housing must be disassembled to replace the mechanical load brake ratchet unit. The hoist gear reducer housing and parts are shown in Figure 9. Figure 9 shows a three-step reduction as used on Series 32 and Series 33 hoists. Series 34 and Series 35 hoists use a four-step reduction. The mechanical load brake shaft on Series 34 and Series 35 hoists will be assembled reversed from that shown in Figure 9. Part numbers for gear reducer assembly parts can be found in the PARTS MANUAL for the specific series of the WRIGHT® WORK-RATED® hoist line.

FIGURE 9

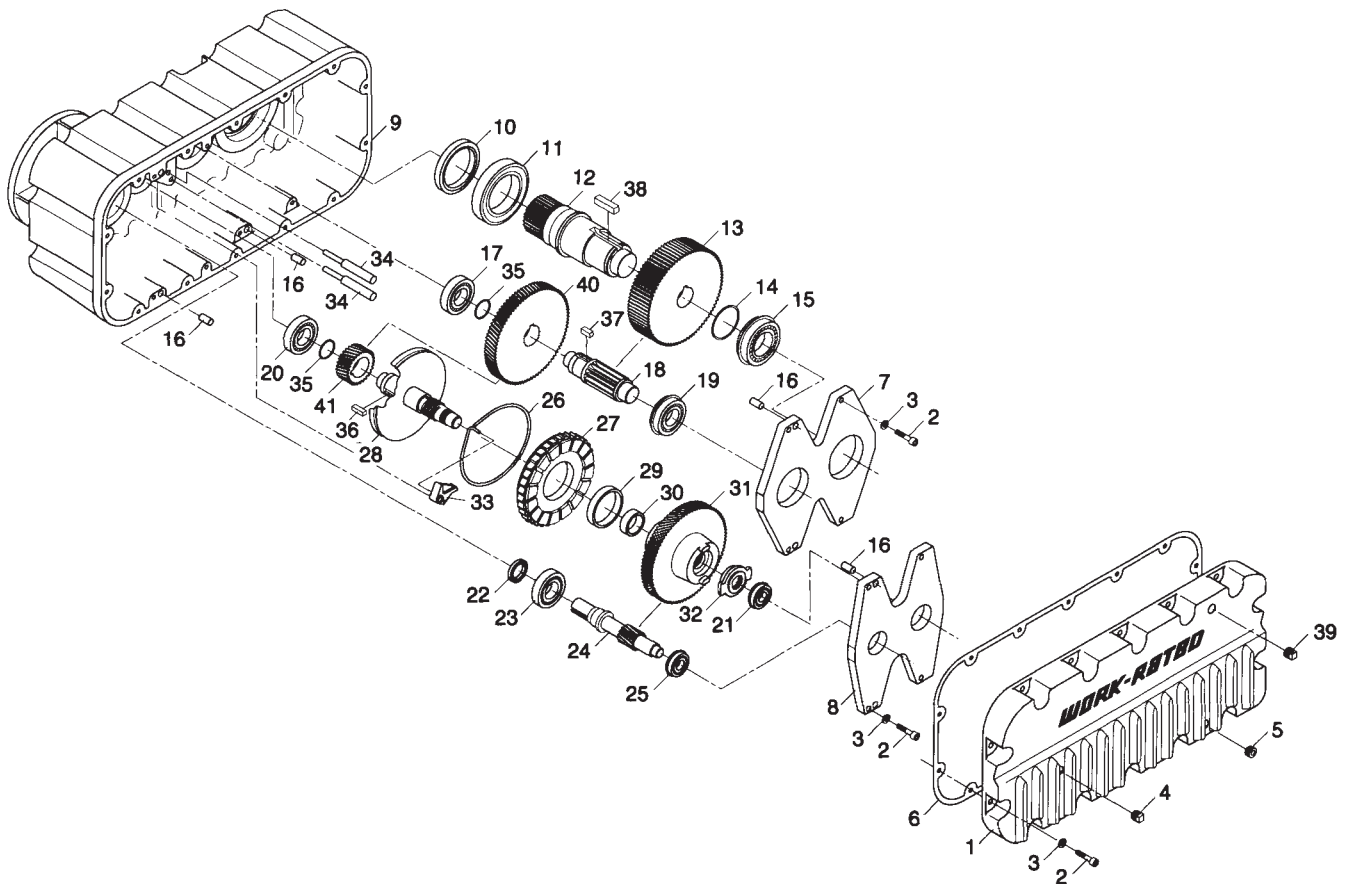

MECHANICAL LOAD BRAKE

Disassemble gear reducer housing assembly as follows:

1. Follow the procedures and instructions listed in the MAINTENANCE AND INSPECTION PROCEDURES section of this manual.
2. Block the drum to prevent it from rotating due to the weight of the wire rope and load block when meshing of the gears in the gear reduction is interrupted because of disassembly.
3. Remove the drain plug (5) from the gear housing cover (1) to drain the lubricant from hoist gear reducer housing. Discard gear housing lubricant in an approved manner. Do not reuse lubricant. When unit is reassembled, new lubricant should be used.
4. Loosen and remove the bolts (2) and lockwashers (3) holding the gear housing cover (1) to the gear housing (9) and remove the gear housing cover (1).
5. Remove and discard gear cover gasket (6). Do not reuse gasket. When unit is reassembled, a new gasket should be used.
6. Loosen and remove the bolts (2) and lockwashers (3) holding the gear spiders (7) and (8) to the gear housing (9). Remove gear spiders (7) and (8).
7. Rotate mechanical load brake assembly clockwise on Series 32 and Series 33 hoists, or counterclockwise on Series 34 and Series 35 hoists, to release pawl (33) from slot in ratchet. Remove pins (34), then remove pawl (33) from pawl spring (26).
8. Remove mechanical load brake unit (28, 26, 27, 29, 30, 31, 32, 36, 41, and 35) and take it to a service area.
9. Remove bearing (21) and check sleeve (32) from brake shaft (28).
10. Rotate brake gear (31) counterclockwise and remove from brake shaft (28).
11. Remove ratchet unit (27) and measure thickness of linings on each side of ratchet. Replace ratchet unit if the thickness of either lining has worn to $\frac{1}{8}$ (3.2 mm) or less.
12. While gear housing is disassembled, inspect all parts for wear or damage that would indicate a need for replacement. Replace parts as required when reassembly is performed.

Reassemble gear reducer housing assembly as follows:

1. Lightly coat linings on ratchet unit (27) and inside hub of brake gear (31) with new gear housing lubricant. Refer to LUBRICATION section of this manual.
2. Assemble ratchet unit (27) on brake shaft (28) with ratchet teeth pointing counterclockwise as shown in Figure 10. Counterclockwise direction of teeth applies to assembly of ratchet unit on brake shaft only, and does not indicate direction of ratchet teeth when assembled into gear housing.

FIGURE 10

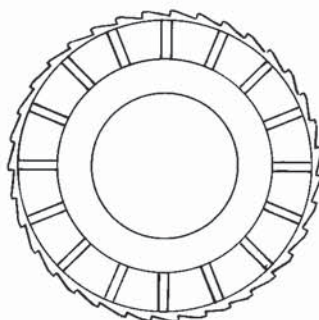
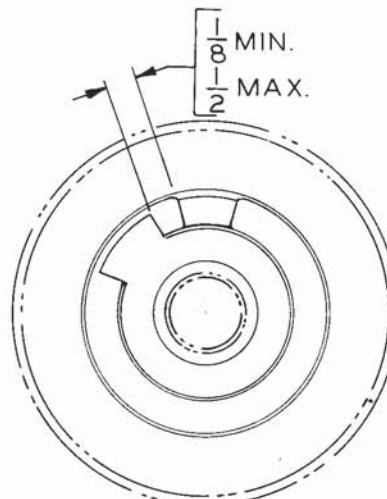

FIGURE 11



MECHANICAL LOAD BRAKE

3. Rotate brake gear (31) clockwise onto brake shaft (28) handtight against ratchet unit (27).
4. Place check sleeve (32) on splined end of brake shaft (28) with clearance between stop lugs on check sleeve (32) and brake gear (31) as shown in Figure 11. Clearance between the stop lugs should be set as close to the minimum clearance ($\frac{1}{8}$ inch.) as possible. If clearance between stop lugs on check sleeve (32) and brake gear (31) within the minimum and maximum shown in Figure 11 cannot be achieved, adjustment should be continued as follows:
 - a. Remove check sleeve (32) from brake shaft (28).
 - b. Rotate brake gear (31) counterclockwise off of brake shaft (28) and mark on the brake gear the end of the last thread to be engaged with the brake shaft (28). Brake gear (31) has a multi-start thread.
 - c. Reassemble, starting at step 3, beginning with a different thread.
 - d. Use thread assembly that produces clearance closest to specified minimum.
5. For Series 32 and Series 33 hoists: Replace bearing (21) on brake gear end of brake shaft (28).
For Series 34 and Series 35 hoists: Replace bearing (21) on pinion end of brake shaft (28).
6. Replace mechanical load brake unit in gear housing.
 - a. For Series 32 and Series 33 hoists: Insert pinion end of brake shaft into bearing (20), meshing pinion teeth with teeth of gear (40).
For Series 34 and Series 35 hoists: Insert brake gear end of brake shaft into bearing (20), meshing pinion teeth with teeth of gear (40).
 - b. Rotate brake shaft until right angle bend of pawl spring (26) is next to pawl slot in housing.
 - c. Place pawl (33) on end of spring and rotate brake shaft until pawl is in pawl slot.
 - d. Replace pawl pins (34) to secure pawl (33).
7. Check mesh of all pinions and gears.
8. Position spiders (7) and (8) over bearings and dowel pins (16) in housing.
9. Secure spiders (7) and (8) to gear housing with bolts (2) and lockwashers (3). Bolts (2) should be tightened to a torque of 30 lb ft (40.6 Nm).
10. Apply RTV Sealant to the face of the gear housing. Apply as a continuous bead around the gear housing, keeping the bead inside of (or completely around) the gear housing cover holes.
11. Secure gear cover (1) to gear housing with bolts (2) and lockwashers (3). Bolts (2) should be tightened to a torque of 30 lb ft (40.6 Nm).
12. Replace drain plug (5).
13. Fill the gear reducer with new lubricant as outlined in the LUBRICATION section of this manual.
14. Remove the blocks that were used to prevent the drum from rotating prior to returning the hoist to regular service.
15. Test the hoist before returning the hoist to regular service.

HOIST MOTOR BRAKE

WRIGHT® WORK-RATED® hoists are furnished with a WRIGHT® hoist motor brake specified as standard. The hoist motor brake is located on the end of the hoist motor opposite the hoist gear reducer housing. The hoist motor brake operates in conjunction with the mechanical load brake to comprise the hoist braking system. When specified, another type of hoist motor brake will be furnished in place of the WRIGHT® hoist motor brake. Standard specified hoist motor sizes and hoist motor brake ratings for WORK-RATED® hoists are listed in Table 9.

TABLE 9
WRIGHT® WORK-RATED® HOISTS
STANDARD SPECIFIED MOTORS AND MOTOR BRAKES

HOIST MOTOR SIZE	HOIST MOTOR BRAKE RATING
3 HP	18 lb ft
5 HP	33 lb ft
7½ HP	45 lb ft
10 HP	45 lb ft (single speed) 68 lb ft (two speed)
15 HP	68 lb ft
20 HP	90 lb ft

The WRIGHT® hoist motor brake is a direct-acting, disc-type brake operated by rectified direct current (DC). It is equipped with an interlocking switch designed to prevent the hoist motor from starting before the brake is released. Refer to Figure 12 for an electrical schematic of the hoist motor brake. Note that in Figure 12, travel limits and other protective devices have been purposely omitted for simplification.

FIGURE 12

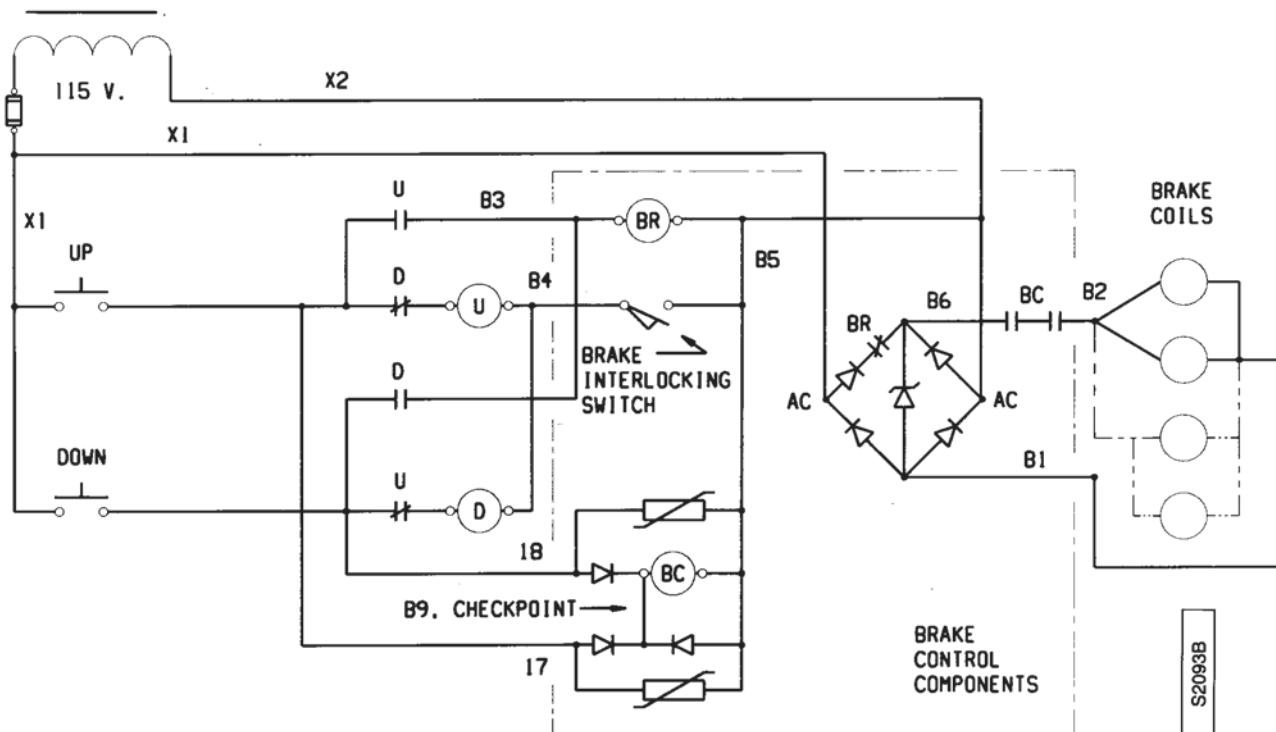

HOIST MOTOR BRAKE

Operation of the hoist motor brake is as follows:

1. Relay BC is energized by directional control button or device to energize brake coils to release brake.
2. Brake interlock switch closes allowing hoist motor to start. If brake is out of adjustment, the brake interlock switch will not close and hoist motor will not start.
3. Relay BR opens to reduce voltage and current flow to the brake coils after brake has released.

The hoist braking system on hoists in regular service should be checked without load on the hook by the operator at the start of each shift, or the first time the hoist is to be operated during each shift. The hoist braking system should be checked during scheduled frequent and periodic inspections.

During daily, frequent, or periodic inspections, the hoist braking system should be checked as follows:

1. Operate hoist in the lifting and lowering direction, without load on the hook, and stop hook motion to check operation of the hoist braking system. The drift of the hook should not exceed one inch in either direction. If hook drift exceeds one inch, the motor brake normally requires adjustment or lining replacement.
2. After completing motor brake adjustment or lining replacement, operate hoist in the lifting and lowering direction, without load on the hook, and stop motion to check operation of the hoist braking system. If hook drift is still excessive, a test of the mechanical load brake should be conducted. Refer to the MECHANICAL LOAD BRAKE section of this manual.

⚠ DANGER

DISCONNECT POWER AND LOCKOUT DISCONNECTING MEANS BEFORE ADJUSTING MOTOR BRAKE.
Only qualified personnel should adjust brakes.

ADJUSTMENT - HOIST MOTOR BRAKE:

FIGURE 13

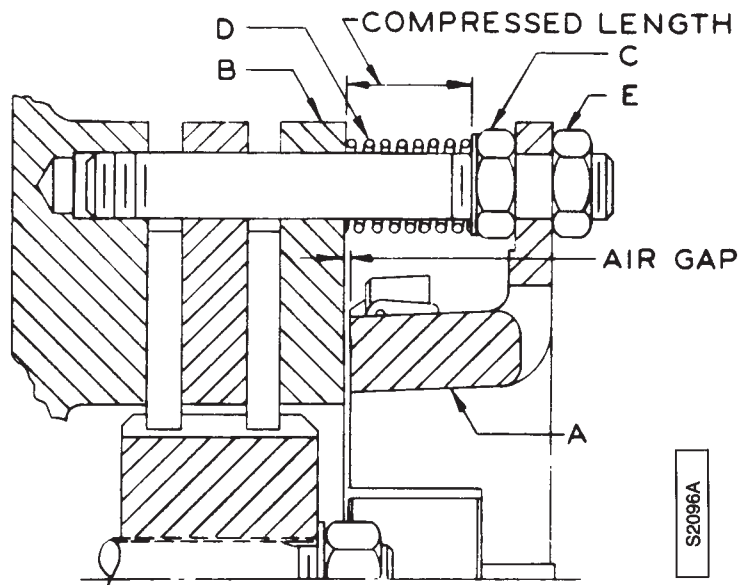

HOIST MOTOR BRAKE

The air gap between magnet (A) and armature plate (B) of Figure 13 is set at 0.03 inch (0.8 mm). As the brake discs wear, this gap increases. When gap is approximately 0.09 inch (2.3 mm), the brake will not release, the interlocking switch will not close, and the hoist motor will not start. It is recommended that the air gap be reset at the minimum setting of 0.03 inch (0.8 mm) whenever the brake cover is removed for inspection or maintenance. For reference only, the compressed length of the spring when the air gap is 0.03 inch (0.8 mm) should be as shown in Table 10. Other brake spring information for identification purposes is listed in Table 10.

**TABLE 10
WRIGHT® WORK-RATED® HOISTS
HOIST MOTOR BRAKE SPRING**

MOTOR BRAKE RATING	SPRING FREE LENGTH	SPRING O.D.	WIRE SIZE	SPRING COLOR	COMPRESSED LENGTH FIGURE 13
18 lb. ft.	2.25 in.	0.850 in.	0.091 in.	Blue	1.656 in.
33 lb. ft.	2.25 in.	0.975 in.	0.115 in.	Cadmium	1.656 in.
45 lb. ft.	2.25 in.	0.975 in.	0.115 in.	Cadmium	1.562 in.
68 lb. ft.	2.00 in.	1.095 in.	0.125 in.	Yellow	1.375 in.
90 lb. ft.	2.25 in.	1.095 in.	0.125 in.	Red	1.438 in.

TO ADJUST AIR GAP:

The hoist motor brake parts are shown in Figure 14. Part numbers for motor brake parts can be found in the PARTS MANUAL for the specific series of the WRIGHT® WORK-RATED® hoist line.

FIGURE 14

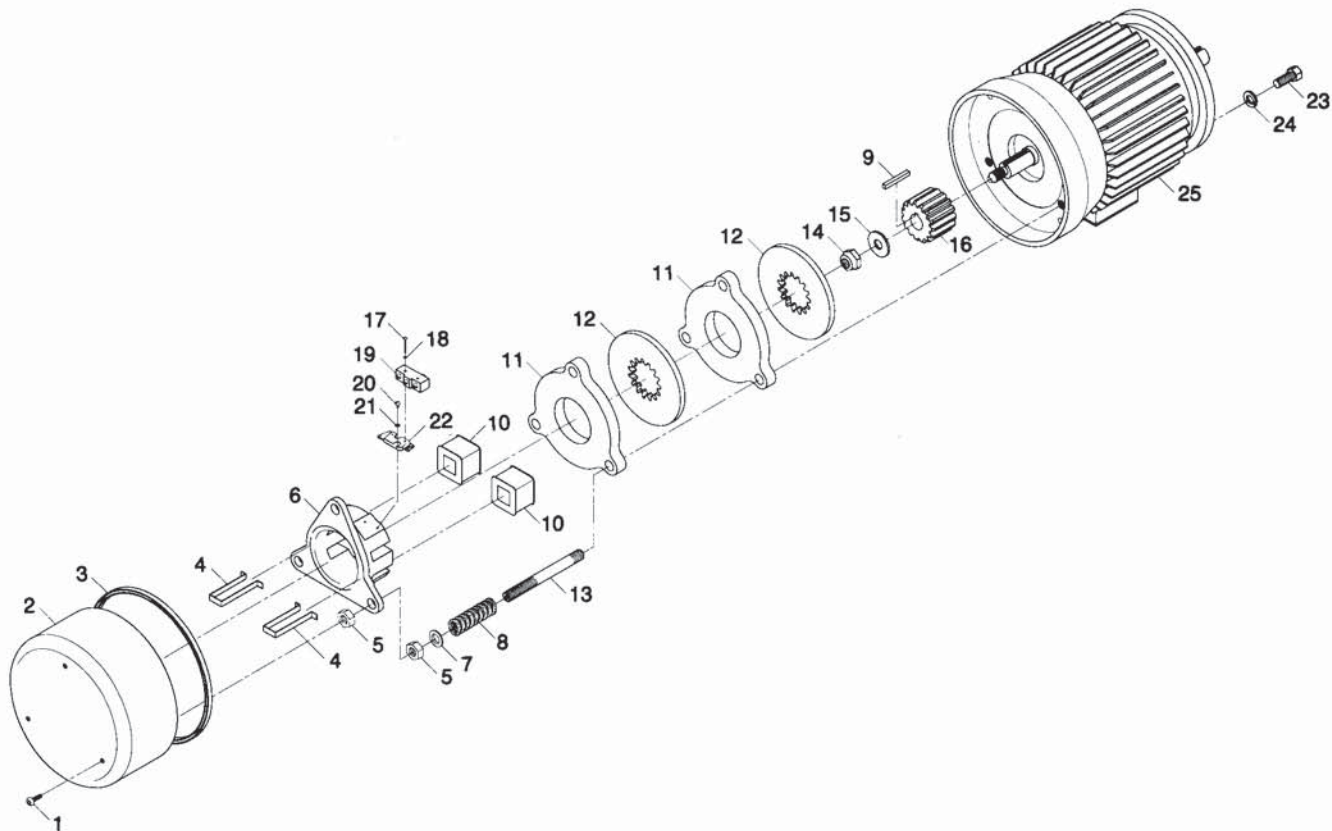

HOIST MOTOR BRAKE

Adjust hoist motor brake air gap as follows: (Refer to Figures 13 and 14)

1. Follow the procedures and instructions listed in the MAINTENANCE AND INSPECTION PROCEDURES section of this manual.
2. Loosen and remove bolts (1) securing brake cover (2).
3. Remove brake cover (2).
4. Use brush or rag to remove any lining dust that has accumulated on brake parts. Specific attention should be directed to removal of dust from the air gap between magnet (A) and armature plate (B).

WARNING

USE PROPER EYE AND BREATHING PROTECTION EQUIPMENT DURING DUST REMOVAL.

5. Turn nuts (C) to compress springs (D) to a compressed length as shown in Table 10.
6. Push magnet (A) toward armature plate (B) against nuts (C).
7. Tighten nuts (E) against magnet (A).

NOTICE

INTERLOCKING SWITCH DOES NOT REQUIRE RESETTING WHEN ONLY AIR GAP IS ADJUSTED. IF BRAKE IS DISASSEMBLED AND PARTS REPLACED, INTERLOCKING SWITCH MAY REQUIRE RESETTING AS OUTLINED LATER IN THIS SECTION.

8. Replace brake cover (2) and secure with bolts (1). Bolts (1) are self-locking type with locking insert. Do not reuse bolts with damaged locking insert or that do not tighten properly. When replacing the brake cover, the ends of the rubber gasket should face downward to prevent water or foreign substances from getting inside the brake cover.

TO REPLACE BRAKE DISCS OR OTHER PARTS:

The hoist motor brake parts are shown in Figure 14. Part numbers for motor brake parts can be found in the PARTS MANUAL for the specific series of the WRIGHT® WORK-RATED® hoist line.

Replace hoist motor brake discs or parts as follows: (Refer to Figures 13 and 14)

1. Follow the procedures and instructions listed in the MAINTENANCE AND INSPECTION PROCEDURES section of this manual.
2. Loosen and remove bolts (1) securing brake cover (2).
3. Remove brake cover (2).
4. Use brush or rag to remove any lining dust that has accumulated on brake parts. Specific attention should be directed to removal of dust from the air gap between magnet (A) and armature plate (B).

WARNING

USE PROPER EYE AND BREATHING PROTECTION EQUIPMENT DURING DUST REMOVAL.

HOIST MOTOR BRAKE

5. Rotate nuts (E) and remove from brake studs (13).
6. Remove magnet (A) from brake studs (13).
7. Rotate nuts (C) and remove from brake studs (13).
8. Remove springs (8) from brake studs (13).
9. Remove armature plates (11) from brake studs (13), and brake discs (12) from brake hub (16).
10. Inspect all parts as outlined in the "Motor Brake Inspection" instructions of this section. Replace parts as required and reassemble motor brake.
11. Replace brake discs (12) on brake hub (16), and armature plates (11) on brake studs (13) in the order shown in Figure 14.
12. Replace springs (8) on brake studs (13).
13. Replace nuts (C) on brake studs (13) and turn nuts (C) to compress springs (D) to a compressed length as shown in Table 10.
14. Replace magnet (A) on brake studs (13) and push magnet (A) toward armature plate (B) against nuts (C).

NOTICE

ARMATURE PLATES OF THE 45 LB FT BRAKE HAVE A PROJECTION TO ENGAGE THE PLUNGER OF THE INTERLOCKING SWITCH. ALIGN THIS PROJECTION WITH THE INTERLOCKING SWITCH PLUNGER DURING ASSEMBLY. REFER TO FIGURE 15.

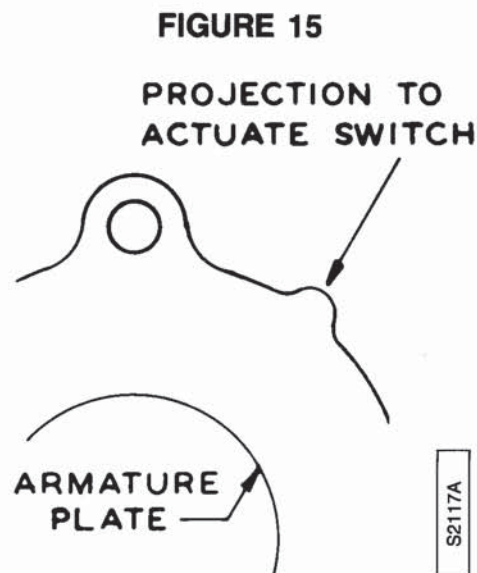

HOIST MOTOR BRAKE

15. Replace nuts (E) on brake studs (13) and tighten nuts (E) against magnet (A).

NOTICE

INTERLOCKING SWITCH DOES NOT REQUIRE RESETTING UNLESS IT HAS BEEN REPLACED OR IF AN OLD SWITCH HAS BEEN ATTACHED TO A REPLACEMENT MAGNET.

16. Reset interlocking switch, if required, as follows:
 - a. Loosen bracket screw to allow support to pivot.
 - b. Insert 0.015 inch (0.40 mm) feeler gauge between switch button and armature plate (B).
 - c. Pivot switch toward armature plate (B).
 - d. Use an ohmmeter or continuity tester, and hold switch in position that indicates switch has closed.
 - e. Tighten bracket screw to secure this position.
 - f. Before removing ohmmeter or continuity tester, insert and remove feeler gauge several times. This should cause the switch to close when the feeler gauge is inserted and open when the feeler gauge is removed; and is a check of proper position and operation of the switch.
17. Replace brake cover (2) and secure with bolts (1). Bolts (1) are self-locking type with locking insert. Do not reuse bolts with damaged locking insert or that do not tighten properly. When replacing the brake cover, the ends of the rubber gasket should face downward to prevent water or foreign substances from getting inside the brake cover.

MOTOR BRAKE INSPECTION:

The hoist motor brake and parts are shown in Figures 13 and 14. Hoist motor brake should be inspected every three months, and during scheduled frequent and periodic inspections, as follows:

1. Follow the procedures and instructions listed in the MAINTENANCE AND INSPECTION PROCEDURES section of this manual.
2. Loosen and remove bolts (1) securing brake cover (2).
3. Remove brake cover (2).
4. Use brush or rag to remove any lining dust that has accumulated on brake parts. Specific attention should be directed to removal of dust from the air gap between magnet (A) and armature plate (B).

WARNING

USE PROPER EYE AND BREATHING PROTECTION EQUIPMENT DURING DUST REMOVAL.

5. Check brake coils (10) for proper fit and retention in magnet (6). Adjust coil straps (4) to tighten.
6. Check for loose electrical connections or broken wires. Repair or replace as required.
7. Check thickness of brake discs (12). Replace both discs if either disc has worn to a thickness of 3/16 inch (4.8 mm) or less. ALWAYS REPLACE BRAKE DISCS IN PAIRS.

HOIST MOTOR BRAKE

8. Check air gap and adjust if required. Minimum air gap - 0.03 inch (0.8 mm) Maximum air gap - 0.09 inch (2.3 mm) Adjust in accordance with "To Adjust Air Gap" instructions of this section.
9. If motor brake is disassembled, or during a general overhaul of hoist, inspect armature plates (11) for warping as shown in Figure 16.

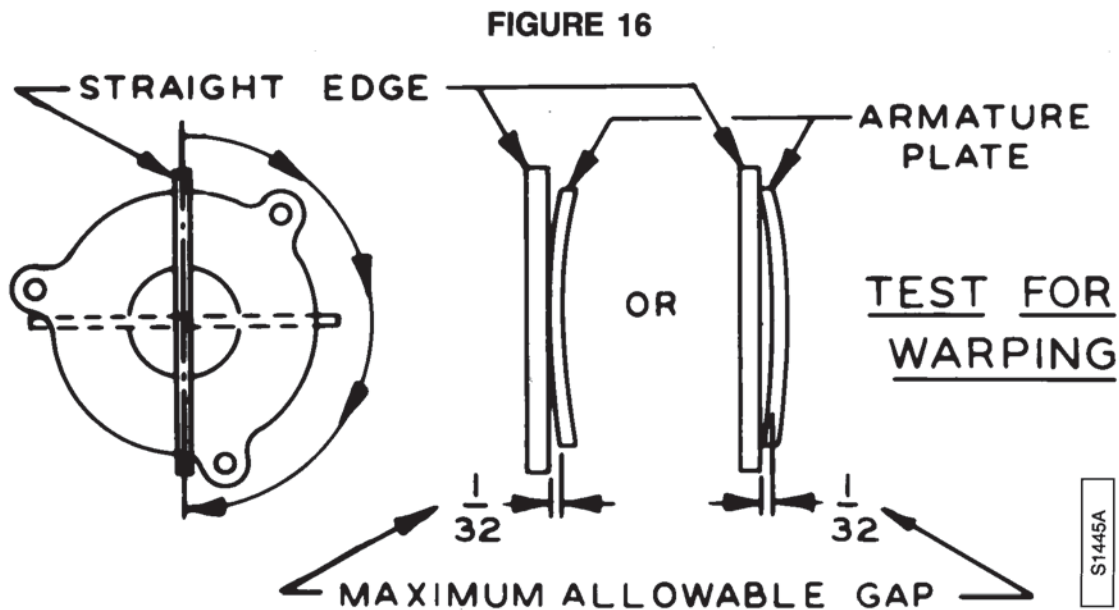

- a. Place armature plate (11) flat on a flat level surface.
 - b. Lay straight edge across center of armature plate.
 - c. Check for any gaps between straight edge and armature plate.
 - d. Rotate straight edge 180° on armature plate, checking for gaps.
 - e. Any armature plate that has warping gaps of 1/32 inch or more, as shown in Figure 16 requires replacement.
10. After inspection is completed, reassemble motor brake in accordance with "TO ADJUST AIR GAP" or "TO REPLACE BRAKE DISCS OR OTHER PARTS" instructions.

HOIST MOTOR BRAKE

BRAKE CONTROL COMPONENTS:

FIGURE 17

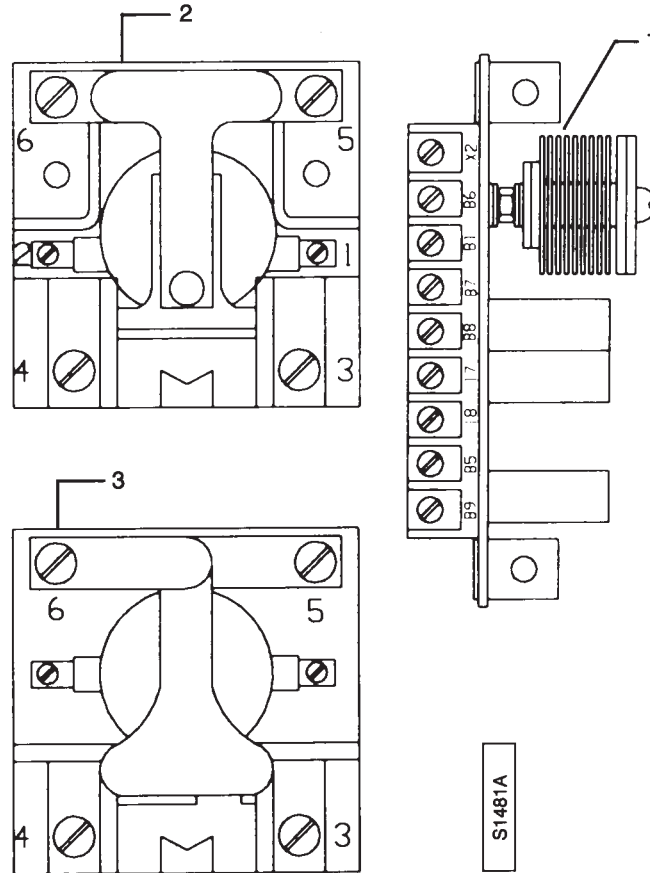

Figure 17 represents a typical configuration of brake control components on an electrical panel. Refer to the hoist wiring diagram for terminal markings and wiring connections.

To order brake control components, provide part number, description, quantity required, and hoist serial number. Quantities shown in Table 11 are for one hoist. Item numbers in Table 11 refer to Figure 17.

TABLE 11
WRIGHT® WORK-RATED® HOISTS
BRAKE CONTROL COMPONENTS

ITEM NO.	PART NO.	DESCRIPTION	QUANTITY
1	86712	Brake Control Circuit Board	◆ 1
2	PA6496	Brake Control Relay (BC) 115V Control	1
3	PA6254	Brake Relay (BR) 115V Control	1

◆ Recommended Spare Parts

HOIST MOTOR BRAKE

PROCEDURE FOR CHECKING MOTOR BRAKE AND BRAKE CONTROL COMPONENTS:

⚠ DANGER

DISCONNECT POWER AND LOCKOUT DISCONNECTING MEANS BEFORE ADJUSTING OR SERVICING MOTOR BRAKE.
 Only qualified personnel should adjust and service brakes.

Values shown in charts below are for 115V control circuit. For 24V control circuit, the same procedure is followed; however, the values will vary. Refer to Figure 12 for an electrical schematic of the hoist motor brake. Note that in Figure 12, travel limits and other protective devices have been purposely omitted for simplification.

FIGURE 18

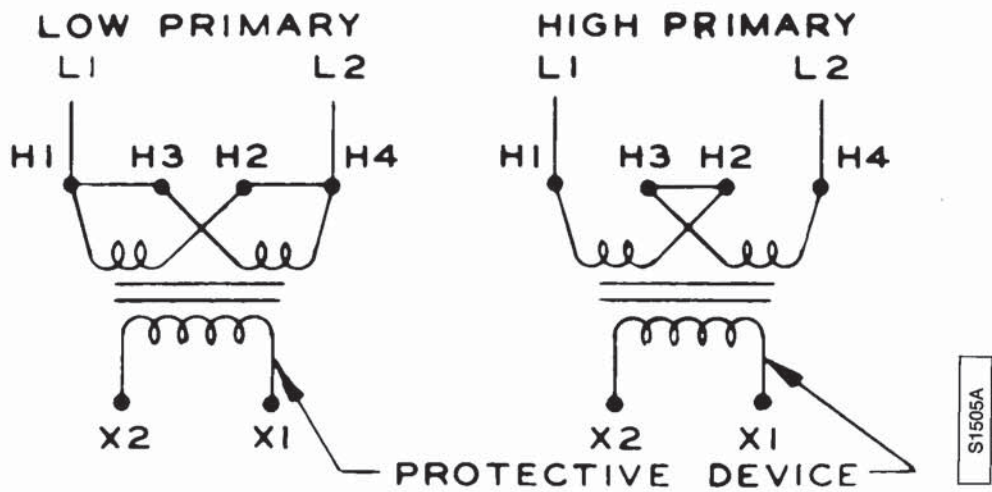

1. Visual inspection as per Table 12.

TABLE 12

LOCATION	SYMPTOM	REMEDY
Armature gap	Exceeds recommended maximum (0.090 in.; 2.3 mm)	Adjust per instructions
Control panel	Excessive wear; pitting of relay contacts	Replace relay. Never file contact points.

HOIST MOTOR BRAKE

2. If relay BC does not energize when hoist control device is operated, check the following:

a. Check voltage with power on as per Table 13. Refer to Figure 18.

TABLE 13

PROCEDURE	CORRECT METER READING	REMEDY CORRECT VOLTAGE	REMEDY INCORRECT VOLTAGE
Measure voltage between H1 and H4	Same as supply voltage	Proceed to next step	Problem is between transformer and power supply
Measure voltage between X1 and X2	104-127 VAC (22-26 VAC on 24 volt control)	Skip fuse check and proceed to next step	Check fuse

b. Check fuse with power on as follows:

(1) Attach voltmeter to X2 and opposite side of fuse from X1. Refer to figure 12.

(2) Correct voltage indicates fuse is blown. Remove fuse. With fuse removed and power off, conduct an ohmmeter check as per Table 14. Take readings on the R times 1 scale only.

TABLE 14

CONNECT POSITIVE PROBE TO:	CONNECT NEGATIVE PROBE TO:	MINIMUM OHMMETER READING	REMEDY CORRECT READING	REMEDY INCORRECT READING
X1	X2	∞	Proceed to next step	See note 1
X2	X1	∞	Proceed to next step	See note 1
X2	17	∞	Proceed to next step	See note 1
X2	18	∞	Proceed to next step	See note 1
X2	B3	70Ω-300Ω	Proceed to next step	Replace BR
X2	B9	10-1200Ω	Proceed to next step	Replace BC

Note 1: Replace brake control circuit board

c. Incorrect or no voltage at transformer secondary with correct voltage at primary indicates transformer is damaged. Replace transformer.

HOIST MOTOR BRAKE

3. If relay BC energizes but brake does not release, check the following:

a. With power off, remove BR coil lead at terminal B3. Reconnect power supply. Check voltage as per Table 15.

TABLE 15

PROCEDURE	CORRECT METER READING	REMEDY CORRECT VOLTAGE	REMEDY LOW VOLTAGE 45-56 VDC	REMEDY NO VOLTAGE
Depress UP or DOWN control and measure voltage between terminals B1 and B2.	92-112 VDC	Proceed to steps 3B and 3C.	Check normally closed contacts of relay BR for sticking in open position. Replace if necessary.	Replace brake control circuit board.

b. With power off, replace BR coil lead at terminal B3.

c. Check voltage as per Table 16.

TABLE 16

PROCEDURE	CORRECT METER READING	VOLTAGE	NO VOLTAGE
Depress UP or DOWN control and measure voltage between terminals B9 and X2.	45-56 VDC (10-14 VDC on 24 volt control)	Relay BC should pick up. If not, replace relay.	Replace brake control circuit board.

4. If all control components function properly and brake still does not release, check coils with an ohmmeter with power off as per Table 17.

TABLE 17

COMPONENT	CORRECT METER READING	REMEDY
Brake coils. Test each coil separately.	100 ohms (cold) to 125 ohms (warm)	If meter reading is not as noted, replace coil or coils. When replacing coils, note that coils are connected in parallel.

ELECTRICAL COMPONENTS



HAZARDOUS VOLTAGES PRESENT.

DISCONNECT POWER AND LOCKOUT DISCONNECTING MEANS BEFORE INSPECTING OR SERVICING.

Only qualified electricians should inspect, service, repair, or replace electrical components.

ELECTRICAL COMPONENTS INSPECTION:

Electrical components should be inspected every three months, and during scheduled frequent and periodic inspections, as follows:

1. Follow the procedures and instructions listed in the MAINTENANCE AND INSPECTION PROCEDURES section of this manual.
2. Components to examine:
 - a. Magnetic contactors.
 - b. Limit switches.
 - c. Control devices.
 - d. Wiring and connections.
3. Damage to look for:
 - a. Pitting.
 - b. Corrosion.
 - c. Broken parts.
 - d. Damage and deterioration of any kind.
 - e. Damaged or frayed wire.
 - f. Loose terminal connections.
4. Corrective action required:
 - a. Tighten any loose connections.
 - b. Replace any damaged or frayed wires.
 - c. Replace any pitted, burned, or corroded contacts or the entire contactor. Replace contacts in sets only. NEVER attempt to smooth contacts by filing or other means.
 - d. Replace damaged components.
 - e. Lubricate controller parts only if recommended by the controller manufacturer.

ELECTRICAL COMPONENTS

RECONNECTABLE MOTORS:

Standard hoist single-speed motors are reconnectable for 230 volt or 460 volt, three phase, 60 Hz. operation. Standard trolley single-speed motors are reconnectable for 208/230 volt or 460 volt, three-phase, 60 Hz. operation. Such motors and control will be connected at the factory for 460 volt unless otherwise specified. All two-speed motors, 200 volt single-speed motors, and 575 volt single-speed motors are single voltage motors, and are not reconnectable.

If reconnection of a 230/460 volt motor is required, proceed as follows:

1. If hoist is connected to the main power supply, de-energize, lock, and tag the main switch (disconnect).
2. Reconnect the control circuit transformer, located inside the brake and limit switch control enclosure. Connection instructions are located on the transformer. Refer to Table 20 and Figure 22. (Note: Figure 22 is the same as Figure 18.)
3. Reconnect the hoist motor leads inside the hoist motor junction box. Refer to Table 18 and Figures 19 and 20. The hoist motor brake is powered from the control circuit transformer and does not require reconnection.
4. Reconnect the trolley motor leads inside the trolley motor junction box. Refer to Table 18 and Figures 19 and 20.
5. Reconnect the trolley motor brake leads, if so equipped, inside the trolley motor junction box. Refer to Table 21 and Figure 23. Refer to the TROLLEY section of this manual for additional trolley brake information.
6. If the hoist is equipped with optional motor circuit fuses or overload relays sized for the original connection voltage, they must be replaced with ones properly sized for the reconnected voltage.

CAUTION

WHEN RECONNECTING FOR A DIFFERENT VOLTAGE, MOTOR CIRCUIT FUSES AND THERMAL OVERLOADS (IF ANY) MUST BE REPLACED WITH UNITS THAT COMPLY WITH THE NEW VOLTAGE AND CURRENT RATINGS.

WARNING

WHENEVER ANY CHANGES HAVE BEEN MADE, DO NOT OPERATE HOIST UNTIL ALL SAFETY DEVICES HAVE BEEN RECHECKED IN THE SAME MANNER AS DURING ORIGINAL INSTALLATION. REFER TO INSTALLATION SECTION OF THIS MANUAL.

Refer to Table 19 and Figure 21 for two-speed motor connections.

ELECTRICAL COMPONENTS

FIGURE 19

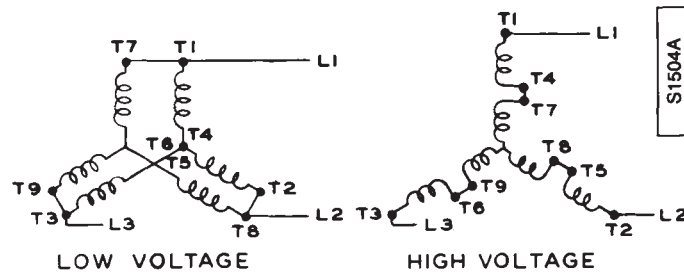

FIGURE 20

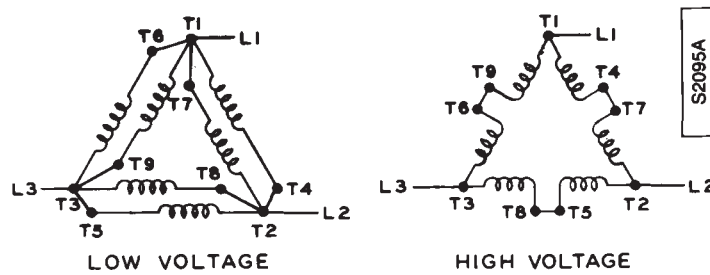

FIGURE 21



FIGURE 22

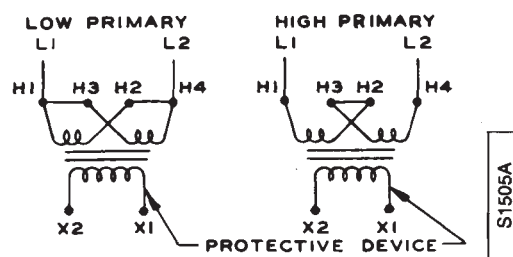
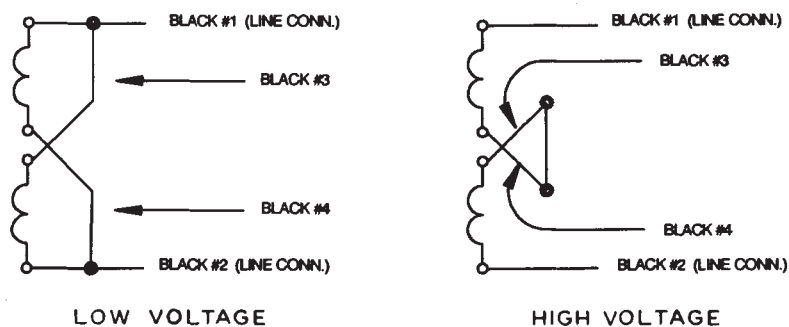

FIGURE 23



ELECTRICAL COMPONENTS

TABLE 18
SINGLE-SPEED MOTOR CONNECTIONS
Y-CONNECTED (Figure 19) DELTA-CONNECTED (Figure 20)

LOW VOLTAGE	HIGH VOLTAGE	LOW VOLTAGE	HIGH VOLTAGE
L1,T1,T7	L1,T1	L1,T1,T6,T7	L1,T1
L2,T2,T8	L2,T2	L2,T2,T4,T8	L2,T2
L3,T3,T9	L3,T3	L3,T3,T5,T9	L3,T3
	T4,T7		T4,T7
T4,T5,T6	T5,T8		T5,T8
	T6,T9		T6,T9

TABLE 19
TWO-SPEED MOTOR CONNECTIONS

LOW SPEED	HIGH SPEED
L1,T1	L1,T11
L2,T2	L2,T12
L3,T3	L3,T13
INSULATE SEPARATELY	INSULATE SEPARATELY
T11-T12-T13	T1-T2-T3

TABLE 20
TRANSFORMER CONNECTIONS
(Figure 22)

LOW VOLTAGE	HIGH VOLTAGE
H1,H3-L1	H1-L1
H2,H4-L2	H4-L2
	H2-H3

TABLE 21
TROLLEY MOTOR BRAKE COIL CONNECTIONS

VOLTAGE	BRAKE COIL PART NO. 39783-3
230 VAC	Figure 23, Low voltage
380 VAC	Figure 23, High voltage
480 VAC	Figure 23, High voltage

ELECTRICAL COMPONENTS

NOTICE

When the hoist is installed on a new or existing crane system that requires a common control voltage between the crane and hoist controls, the following must be adhered to:

1. Primary phasing to the control transformer in both the hoist and crane must be identical.
2. X1 must be connected between the hoist and crane controls.
3. The X2 secondary leads **MUST NOT** be connected together or to ground.

FAILURE TO FOLLOW THESE GUIDELINES WILL RESULT IN MISMATCHED VOLTAGES AND BLOWN CONTROL TRANSFORMER FUSES.

On installations where a grounded X2 secondary is required, **SEPARATE** X1 leads must be used for:

1. the mainline contactor (on the crane) and crane motion, and
2. the trolley/hoist motion controls or push buttons.

The X1 of transformers with grounded X2 secondaries **MUST NOT** be tied together.

If additional information is required, contact Acco Material Handling Solutions or the distributor of the hoist.

ACCELERATION CONTROL MODULE V

An Acceleration Control Module V (ACM V) is available as an optional feature on all power-driven trolleys using a three-phase electric motor. The ACM V is a solid state device designed to provide reduced starting torque and controlled acceleration of three-phase motors. The ACM V offers a soft controlled start that reduces the swinging action of suspended loads caused by uncontrolled abrupt starts. Starting torque and acceleration rate can be adjusted to accommodate differing requirements.

DANGER

HAZARDOUS VOLTAGES ARE PRESENT IN THE CONTROL BOX, OTHER ELECTRICAL COMPONENTS, AND CONNECTIONS BETWEEN THESE COMPONENTS.

The main switch (disconnect) of the hoist, crane, or lifting system shall be de-energized. Lock and tag the main switch in the de-energized position in accordance with ANSI Z244.1.

Only qualified electricians should inspect, adjust, service, repair, or replace electrical components.

All adjustments of ACM V must be made with the main switch locked and tagged in the de-energized position. After adjustments are made, re-energize power supply and test operation of ACM V. If additional adjustment is required, repeat this procedure.

NOTICE

Multi-Voltage Controls must be set for correct voltage before operating.

ACM V SINGLE SPEED ADJUSTMENT:

1. Set the TIME adjustment at the maximum point and the INITIAL TORQUE adjustment at the minimum point. (This initial setting provides the softest start, but the initial torque may be too small to start the motor for the first few cycles.)
2. Set the INITIAL TORQUE adjustment first; usually 1/4 to 1/2 of a turn from the minimum torque setting is adequate.
3. Decrease the TIME adjustment if the starting is too soft under a half load condition. Strive for a smooth even transition from zero to maximum speed with a minimal INITIAL TORQUE setting.

ACM V TWO SPEED ADJUSTMENT:

1. Set the TIME adjustment at the maximum point and the ACCELERATION and DECELERATION INITIAL TORQUE adjustments at the minimum points. (This setting provides the softest start, but the initial torque may be too small to start the motor for the first few cycles.)
2. Set the ACCELERATION TORQUE adjustment first; usually 1/4 to 1/2 of a turn from the minimum torque setting is adequate.
3. Next set the DECELERATION TORQUE adjustment by turning it to the minimum torque setting. If the transition from high to low speed is too soft, increase the setting until an appropriate transition is obtained. Usually setting the DECELERATION TORQUE adjustment to minimum proves to be the best setting.

DANGER

SERVICE CHECKS OF THE ACM V REQUIRE THAT THE ELECTRICAL POWER SUPPLY BE ENERGIZED.

THEREFORE, only electricians qualified and certified to work on energized circuits and equipment should perform this service.

ACCELERATION CONTROL MODULE V

NOTICE

All readings should be taken with a standard analog type VOM (volt-ohm-meter)

ACM V SINGLE SPEED SERVICE:

1. Disconnect motor from T1, T2, and T3.
2. Set INITIAL TORQUE adjustment to minimum and the TIME adjustment to maximum.
3. Energize the contactor. For proper operation the following readings should be taken (example is for a 460 VAC, three-phase system with 115 VAC control voltage):
 - a. TL1 to TL2, TL2 to TL3, and TL1 to TL3 - 460 VAC.
 - b. Control signal point A and B terminals - 115 VAC. It is important that this reading be taken across the A and B terminal screws on the ACM unit. If no voltage can be read across these two points, first check for misplacement of an electrical interlock from the reversing or two-speed contactor. The "common" side of the control signal is sensed through the coil which is not *energized*, so do not interlock the common wire out of the circuit. Simply checking for 115 VAC from one screw terminal and the "common" wire is NOT sufficient. Without a proper signal to the A and B terminals (and the HI, LO, and COMMON on two-speed models), the output of the ACM at T1, T2, and T3 will remain zero (0) VAC. A and B must only be connected to the contactor coils, **NEVER THE CONTROL TRANSFORMER**.
 - c. After six seconds, take readings at T1, T2, and T3 (with the motor disconnected).
 - (1) From T1 to T2, T2 to T3, and T1 to T3, the voltage is approximately 80-95% of line voltage. For the 460 VAC ACM, the reading is approximately 405 VAC.
 - (2) A zero (0) VAC output will occur if the proper control signal is not being received (See b above and a, b, and c listed under two-speed service).
 - d. With the TORQUE adjustment at minimum and the TIME adjustment at maximum, take a meter reading across terminals T1, T2, and T3 (as in c(1) above), from the instant the contactor is closed. The meter should move slowly during the first five seconds, then quickly for the last second. The total time to reach 88% of the line voltage should be approximately six to nine seconds. Each phase to phase test should be similar in voltage profile, no matter where the TIME and TORQUE adjustments are set. Due to the dampening factor in volt-ohm-meters, it is difficult to detect the exact voltage level at a particular torque setting. However, the varying of the TORQUE and TIME settings can be readily identified on the meter. **THE IMPORTANT POINT IS THAT ALL THREE VOLTAGE PROFILES ARE THE SAME.**

ACM V TWO SPEED SERVICE:

Steps 1, 2, and 3 are the same as for single-speed control. The difference lies with the control signal circuitry. For proper operation, check the following control signals across the screws on the ACM. See 3b of single-speed service for general testing procedure.

- a. When the contactor is energized for low speed operation, the meter will read:
 - (1) Between HI and COMMON 0 VAC
 - (2) Between LO and COMMON 115 VAC
 - (3) Between LO and HI 115 VAC
 - (4) Between A and B 115 VAC
- b. When the contactor is energized for high speed operation, the meter will read:
 - (1) Between HI and COMMON 115 VAC
 - (2) Between LO and COMMON 0 VAC
 - (3) Between LO and HI 115 VAC
 - (4) Between A and B 115 VAC
- c. If another control voltage is used, it will appear instead of the 115 VAC listed above.

OVERLOAD CUTOFF DEVICE

The WRIGHT® overload cutoff device is standard on all complete WORK-RATED® hoists, unless otherwise specified. The WRIGHT® overload cutoff device is not supplied with winch type units or single line units.

The WRIGHT® overload cutoff device is an electro-mechanical device designed to interrupt the hoist lifting circuit if the load it senses exceeds the preset capacity of the overload cutoff device. When the device interrupts the hoist lifting circuit, the lowering circuit remains intact to allow the hoist load to be lowered and removed. When the excessive overload, that has caused the device to trip, is removed from the hoist hook, the hoist lifting circuit is automatically restored. Under normal operating conditions, the WRIGHT® overload cutoff device will allow the hoist to lift 110% of rated load, but will not allow the hoist to lift 125% of rated load.

⚠ WARNING

THE WRIGHT® OVERLOAD CUTOFF DEVICE IS DESIGNED TO PERMIT THE HOIST TO LIFT A FREELY SUSPENDED LOAD WITHIN ITS RATED LOAD CAPACITY AND TO LIMIT THE AMOUNT OF OVERLOAD THAT CAN BE LIFTED BY A PROPERLY MAINTAINED HOIST, UNDER NORMAL OPERATING CONDITIONS.

VARIABLES EXPERIENCED WITHIN THE HOISTING SYSTEM, SUCH AS, BUT NOT LIMITED TO, ACCELERATION OF THE LOAD, DYNAMICS OF THE SYSTEM, TYPE AND LENGTH OF WIRE ROPE, AND OPERATOR EXPERIENCE, DO NOT PERMIT THE ADJUSTMENT OF AN OVERLOAD CUTOFF DEVICE THAT WOULD PREVENT THE LIFTING OF ANY OVERLOAD OR ANY LOAD IN EXCESS OF RATED LOAD CAPACITY.

THE ADJUSTMENT OF THE WRIGHT® OVERLOAD CUTOFF DEVICE WILL ALLOW THE LIFTING OF AN OVERLOAD OF SUCH MAGNITUDE THAT WILL NOT CAUSE PERMANENT DAMAGE TO A PROPERLY MAINTAINED HOIST, TROLLEY, OR CRANE; AND WILL PREVENT THE LIFTING OF AN OVERLOAD OF SUCH MAGNITUDE THAT COULD CAUSE PERMANENT DAMAGE TO A PROPERLY MAINTAINED HOIST, TROLLEY, OR CRANE.

THE WRIGHT® OVERLOAD CUTOFF DEVICE IS ACTUATED ONLY BY LOADS INCURRED WHEN LIFTING A FREELY SUSPENDED LOAD ON THE HOIST HOOK. THEREFORE, THE WRIGHT® OVERLOAD CUTOFF DEVICE CANNOT BE RELIED UPON TO RENDER THE HOISTING MECHANISM INOPERATIVE IF OTHER SOURCES, SUCH AS, BUT NOT LIMITED TO, SNAGGING OF THE LOAD, TWO BLOCKING OF THE LOAD BLOCK, OR SNATCHING A LOAD, INDUCE LOADS INTO THE HOISTING SYSTEM.

THE WRIGHT® OVERLOAD CUTOFF DEVICE IS CONNECTED IN THE HOIST LIFTING CONTROL CIRCUIT AND, THEREFORE, WILL NOT PREVENT DAMAGE TO THE HOIST, TROLLEY, OR CRANE IF EXCESSIVE OVERLOADS ARE INDUCED INTO THE HOISTING SYSTEM WHEN THE HOISTING MECHANISM IS IN A NON-OPERATING OR STATIC MODE.

THE WRIGHT® OVERLOAD CUTOFF DEVICE IS AN EMERGENCY DEVICE ONLY AND SHALL NOT BE USED TO MEASURE THE MAXIMUM LOAD TO BE LIFTED, OR TO SENSE ANY OVERLOAD IMPOSED BY A CONSTRAINED LOAD.

FIGURE 24

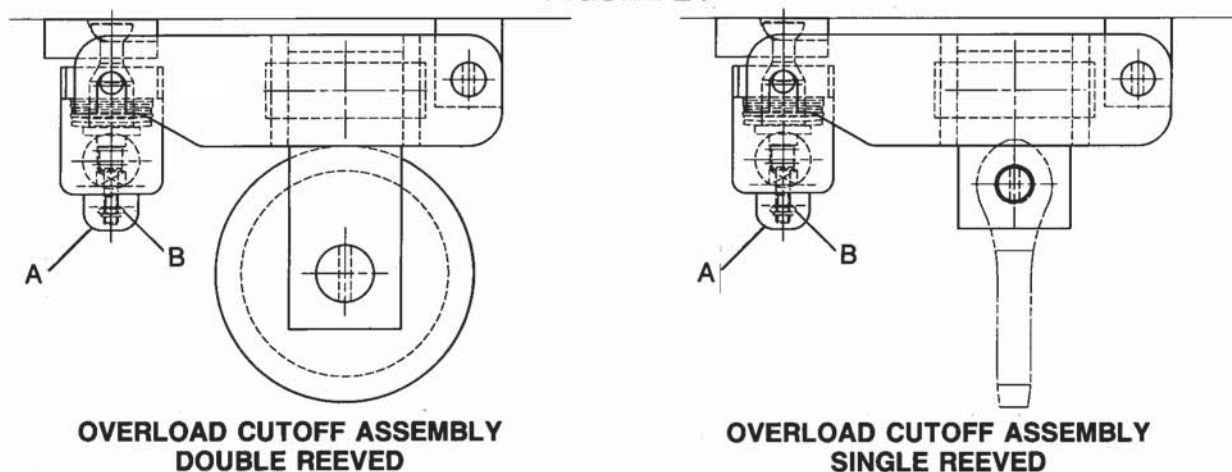

OVERLOAD CUTOFF DEVICE

The WRIGHT® overload cutoff device unit is mounted in the frame of the hoist. Figure 24 shows the overload cutoff device unit and the equalizing sheave hanger unit (double-reeved hoists), or wire rope dead end hanger unit (single-reeved hoists) that will actuate the overload cutoff device.

OVERLOAD CUTOFF DEVICE ADJUSTMENT:

If it becomes necessary to readjust or calibrate the overload cutoff device, proceed as follows:

1. Remove adjusting nut cover (A).
2. Make necessary adjustment of adjusting nut (B) as follows:
 - To increase load lifting capacity, turn adjusting nut (B) in small increments (5° to 10°) counter-clockwise until required test load can be lifted.
 - To decrease load lifting capacity, turn adjusting nut (B) in small increments (5° to 10°) clockwise until required setting is achieved.
3. Operate hoist in the lifting direction to confirm overload cutoff device setting.
4. If overload cutoff device requires additional adjustment, remove load from hoist hook and repeat step 2.
5. After adjustment is completed, replace adjusting nut cover.

NOTICE

When adjusting an overload cutoff device on two-speed or variable speed hoists, adjustment setting should be made at the higher lifting speed. This may permit the hoist to operate with higher loads at low speed, but will not subject the hoist to dynamic loads greater than the dynamic load experienced when lifting rated load at high speed. Adjustment may be made at a lower speed if required; however, the overload cutoff device may activate at loads less than rated load, or setting load, when operating at higher speeds.

WIRE ROPE

Wire rope on hoists in regular service should be visually inspected daily by the operator. If the hoist is used in multiple-shift operations, wire rope should be visually inspected by the operator at the start of each shift. The daily inspection by the operator is for visual damage to the wire rope. Such damage includes excessive broken wires or wear, broken strand, kinks, birdcaging, or damage resulting in deformation of the wire rope structure. When visual damage is present, the operator shall report such damage to the supervisor, and shall not operate the hoist until a more detailed inspection is performed to determine that the wire rope can be used, or the wire rope is replaced. Detailed inspection procedures are outlined below. These procedures also apply to scheduled frequent and periodic inspections.

⚠ WARNING

DO NOT OPERATE A HOIST WITH WIRE ROPE THAT SHOWS ANY SIGN OF DAMAGE, DEFORMATION, OR EXCESSIVE WEAR.

Wire rope consists of a core, strands, and wires that comprise a strand as shown in Figure 25. The diameter of the wire rope is the diameter of a circle that would enclose the wire rope strands. Correct and incorrect methods of measuring wire-rope diameter are shown in Figure 26. The term one rope lay refers to the length of wire rope assembly wherein one strand completely wraps 360° around the wire-rope assembly.

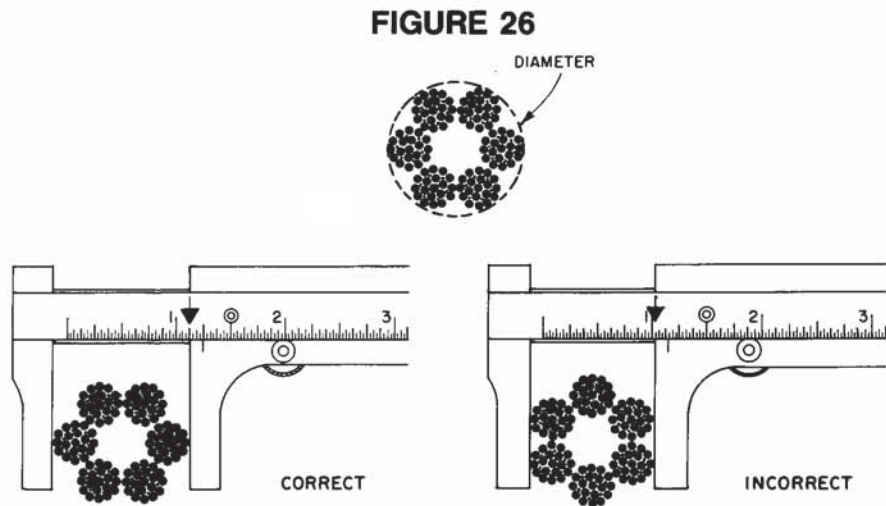
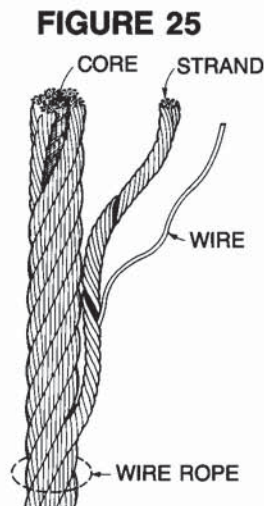

WIRE ROPE INSPECTION:

⚠ CAUTION

ALWAYS WEAR GLOVES OR OTHER HAND PROTECTION DEVICES WHEN HANDLING WIRE ROPE.

Wire rope items to inspect during scheduled frequent and periodic inspections; or if the daily visual inspection by the operator indicates a more detailed inspection is required; are as follows:

1. Rope distortion such as kinking, crushing, unstranding, birdcaging, main strand displacement, or core protrusion.
2. General corrosion.
3. Broken or cut strands.
4. Number, distribution, and type of visible broken or cut wires.
5. Reduction of rope diameter due to loss of core support, or internal or external corrosion, or wear.
6. Damage from heat.

WIRE ROPE

7. Reduction of nominal rope diameter of more than 5%.
8. Corroded or broken wires at end connections.
9. Corroded, cracked, bent, worn, damaged, or improperly applied end connections.
10. Rope lubrication, if recommended.

During wire rope inspection, special attention should be directed to sections of rope subject to rapid deterioration such as the following:

- Rope sections in contact with saddles, equalizer sheaves, or other sheaves where rope travel is limited.
- Rope sections at or near terminal ends where corroded or broken wires may protrude.
- Rope sections subject to reverse bends.
- Rope sections that are normally hidden during visual inspections, such as sections passing over sheaves.

Rope conditions found during the inspection should be recorded in a written report. Amount and type of rope deterioration from one inspection report until the next inspection report should be evaluated for determination if rope replacement is required.

WIRE ROPE REPLACEMENT:

Rope conditions found during the inspection, in addition to review of previous inspection reports, should be the basis for determination that hoist use should be discontinued and that rope replacement is required. Once determined that rope replacement is required, the hoist may be allowed to operate to the end of the work shift, based on the judgment of a qualified person; The rope shall be replaced after that work shift, at the end of the day, or at the latest time prior to the equipment being used by the next work shift. Rope conditions requiring replacement of the rope are as follows:

1. One broken strand.
2. Six randomly distributed broken wires in a length equal to six rope diameters, except as noted in line 4.
3. Three broken wires in one strand in a length equal to six rope diameters, except as noted in line 4.
4. In rotation-resistant ropes, two randomly distributed broken wires in a length equal to six rope diameters or four randomly distributed broken wires in a length equal to thirty rope diameters.
5. One outer wire broken at the contact point with the core of the rope that has worked its way out of the rope structure and protrudes or loops out from the rope structure.
6. Kinking, crushing, unstranding, birdcaging, main strand displacement, core protrusion, or any other damage resulting in deformation or distortion of the rope structure.
7. Evidence of heat damage from any cause.
8. Reduction of rope diameter due to loss of core support or internal or external corrosion.
9. Reduction of rope nominal diameter greater than 5%.
10. Corroded or two broken wires at a socketed or swaged end fitting.
11. Corroded, cracked, bent, damaged, or worn end fitting.

WIRE ROPE MAINTENANCE:

Wire rope assemblies specified with WRIGHT® WORK-RATED® hoists, or furnished as authorized WRIGHT® replacement parts, are manufactured with wire rope constructions and end fittings in accordance with design specifications established by Acco® for the WRIGHT® WORK-RATED® hoist line. Only authorized WRIGHT® wire rope assemblies should be used when replacing wire rope on the hoist.

Specific attention should be directed to the following:

- Wire rope should be stored in a manner to prevent damage or deterioration to the rope.

WIRE ROPE

- Wire rope shall be unreeled or uncoiled in a manner to avoid kinking of or inducing a twist in the rope.
- During installation of wire rope, care should be exercised to avoid dragging the rope in dirt or around objects that will scrape, nick, cut, crush, or induce sharp bends in the rope.
- If recommended, rope should be maintained in a lubricated condition.

The load block on new hoists or after installation of replacement rope may turn when a load is applied or released. Such load block turning may cause the lines of rope to twist about each other. Do not operate the hoist in this condition. This indicates a twist was induced into the rope during installation. Remove the rope from the hoist, lay the rope out to remove any twist, and re-install on the hoist. On single reeved hoists, the twist may be able to be removed by releasing the clevis eye fitting end of wire rope from the dead end connection in the sheave hanger, rotating clevis eye fitting end of wire rope to remove twist, and reattaching the clevis eye fitting end of wire rope to the dead end connection in the sheave hanger.

When replacing wire rope, inspect the drum and sheaves. Drums that have scored grooves or have sharp edges from wear should be smoothed out or the drum should be replaced. Sheaves that have scored grooves, cracked or broken flanges, or sharp edges from wear should be replaced.

TO REPLACE WIRE ROPE:

Instructions for replacing wire rope on the hoist are outlined below. Steps 1 through 5 apply to any hoist, regardless of reeving. Beginning with step 6, follow instructions for either single reeving or double reeving, as required.

Refer to Figures 27, 28, 29, and 30.

1. Follow the procedures and instructions listed in the MAINTENANCE AND INSPECTION PROCEDURES section of this manual.
2. Lower load block to floor or working surface.
3. Disassemble load block covers or load block to remove wire rope from sheaves. Refer to the PARTS IDENTIFICATION pages covering load blocks.
4. Continue to operate hoist to unwind remaining wire rope from the drum. If hoist has a geared limit switch, reset lower limit of the geared limit switch to allow wire rope to unwind completely from the drum. Refer to the LIMIT SWITCHES section of this manual for instructions.
5. Release button end (single reeved) or ends (double reeved) of wire rope from drum openings.

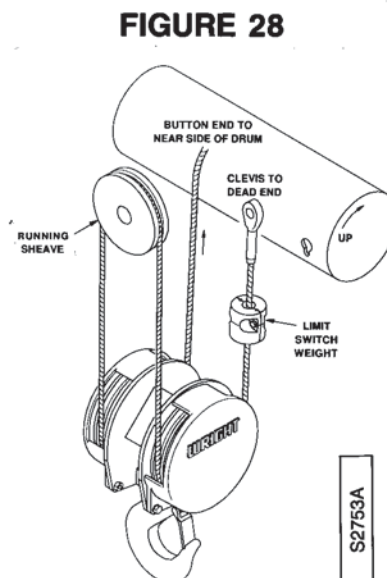
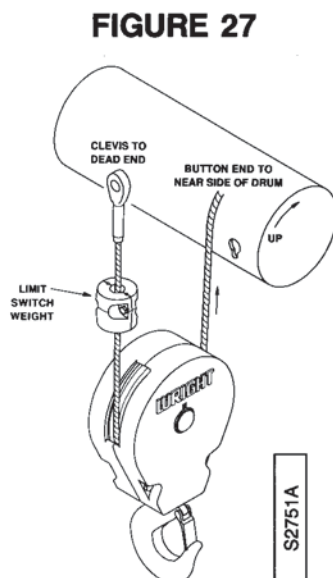

WIRE ROPE

INSTRUCTIONS FOR 2-PART SINGLE REEVED HOISTS ONLY: REFER TO FIGURE 27

6. Release clevis eye fitting end of wire rope from dead end connection in sheave hanger.
7. Install and reeve new wire rope as follows:
 - a. Insert button end of wire rope in drum opening.
 - b. **WEARING PROTECTIVE GLOVES OR OTHER HAND PROTECTION DEVICES, AND KEEPING HANDS WELL AWAY FROM THE DRUM**, guide the wire rope into the drum grooves while operating the hoist in the lifting direction. Leave enough wire rope to reeve through the load block sheave and to reach the dead end. This guiding operation will eliminate most of the twist in the wire rope.

CAUTION

WHEN GUIDING THE WIRE ROPE INTO THE DRUM GROOVES, USE ONLY A LIGHT SQUEEZING PRESSURE. DO NOT SQUEEZE ROPE THAT WILL ALLOW HAND BEING PULLED INTO THE GROOVES AND ROPE. KEEP HANDS WELL POSITIONED AWAY FROM DRUM. ALWAYS WEAR GLOVES OR OTHER HAND PROTECTION DEVICES WHEN HANDLING WIRE ROPE. NEVER HANDLE MOVING WIRE ROPE WITH BARE HANDS.

- c. Reeve wire rope around load block sheave and reassemble load block.
- d. Insert clevis eye fitting end of wire rope through gravity limit switch weight.
- e. Coat hole in clevis eye fitting with Lubriplate 630-AA or 630-2.
- f. Rotate clevis eye fitting end of wire rope to remove any twist between the load block and dead end.
- g. Attach clevis eye fitting end of wire rope to dead end connection in sheave hanger.
- h. Reset the lower limit of the geared limit switch, if provided.
- i. Test all limit switches before returning the hoist to regular service.

WARNING

NEVER OPERATE HOIST WITHOUT THE PROTECTION OF PROPERLY FUNCTIONING LIMIT SWITCHES.

INSTRUCTIONS FOR 4-PART SINGLE REEVED HOISTS ONLY: REFER TO FIGURE 28

6. Remove top running sheave to release wire rope.
7. Release clevis eye fitting end of wire rope from dead end connection in sheave hanger.
8. Install and reeve new wire rope as follows:
 - a. Loop center of wire rope around top running sheave and reassemble running sheave into frame.
 - b. Working toward the button end of the wire rope, eliminate any twist in rope, and reeve rope around one load block sheave.
 - c. Insert button end of wire rope in drum opening.
 - d. **WEARING PROTECTIVE GLOVES OR OTHER HAND PROTECTION DEVICES, AND KEEPING HANDS WELL AWAY FROM THE DRUM**, guide the wire rope into the drum grooves while operating the hoist in the lifting direction. Only wind a few wraps (4 to 6) of wire rope onto the drum.

WIRE ROPE

⚠ CAUTION

WHEN GUIDING THE WIRE ROPE INTO THE DRUM GROOVES, USE ONLY A LIGHT SQUEEZING PRESSURE. DO NOT SQUEEZE ROPE THAT WILL ALLOW HAND BEING PULLED INTO THE GROOVES AND ROPE. KEEP HANDS WELL POSITIONED AWAY FROM DRUM. ALWAYS WEAR GLOVES OR OTHER HAND PROTECTION DEVICES WHEN HANDLING WIRE ROPE. NEVER HANDLE MOVING WIRE ROPE WITH BARE HANDS.

- e. Working from the top running sheave, toward the clevis end of the wire rope, eliminate any twist in rope, and reeve rope around other load block sheave.
- f. Reassemble load block covers.
- g. Insert clevis eye fitting end of wire rope through gravity limit switch weight.
- h. Coat hole in clevis eye fitting with Lubriplate 630-AA or 630-2.
- i. Rotate clevis eye fitting end of wire rope to remove any twist between the load block and dead end.
- j. Attach clevis eye fitting end of wire rope to dead end connection in sheave hanger.
- k. Reset the lower limit of the geared limit switch, if provided.
- l. Test all limit switches before returning the hoist to regular service.

⚠ WARNING

NEVER OPERATE HOIST WITHOUT THE PROTECTION OF PROPERLY FUNCTIONING LIMIT SWITCHES.

FIGURE 29

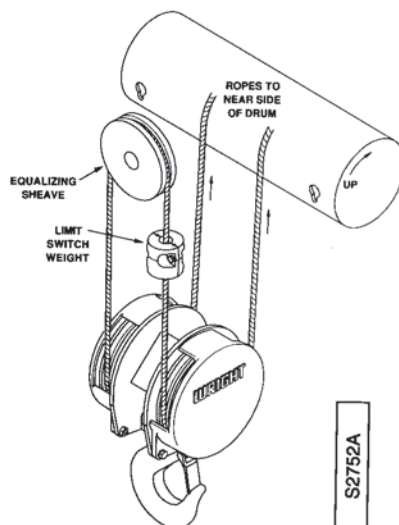
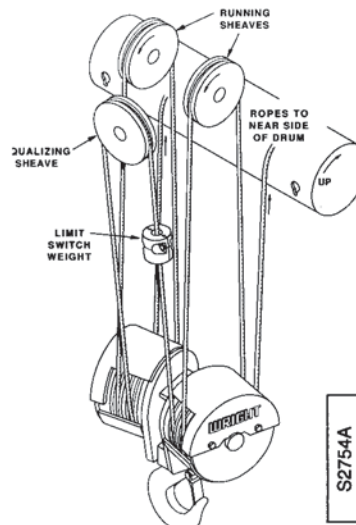

FIGURE 30



WIRE ROPE

INSTRUCTIONS FOR 2-PART DOUBLE REEVED HOISTS ONLY: REFER TO FIGURE 29

6. Remove equalizing sheave from sheave hanger to release wire rope.
7. Install and reeve new wire rope as follows:
 - a. Loop center of wire rope around equalizing sheave and reassemble equalizing sheave into sheave hanger.
 - b. Insert one end of the wire rope from the equalizing sheave through the gravity limit switch weight.
 - c. Working with only one end of the wire rope from the equalizing sheave, eliminate any twist, and reeve around one load block sheave.
 - d. Reassemble load block cover over sheave.
 - e. Insert button end of wire rope into drum opening after eliminating any twist between load block and drum.
 - f. Repeat steps c, d, and e with the other end of the wire rope from the equalizing sheave.
 - g. **WEARING PROTECTIVE GLOVES OR OTHER HAND PROTECTION DEVICES, AND KEEPING HANDS WELL AWAY FROM THE DRUM**, guide the wire ropes into the drum grooves while operating the hoist in the lifting direction.
NOTE: An assistant is required to either operate hoist or guide ropes during this procedure.

CAUTION

WHEN GUIDING THE WIRE ROPE INTO THE DRUM GROOVES, USE ONLY A LIGHT SQUEEZING PRESSURE. DO NOT SQUEEZE ROPE THAT WILL ALLOW HAND BEING PULLED INTO THE GROOVES AND ROPE. KEEP HANDS WELL POSITIONED AWAY FROM DRUM. ALWAYS WEAR GLOVES OR OTHER HAND PROTECTION DEVICES WHEN HANDLING WIRE ROPE. NEVER HANDLE MOVING WIRE ROPE WITH BARE HANDS.

- h. Reset the lower limit of the geared limit switch, if provided.
- i. Test all limit switches before returning the hoist to regular service.

WARNING

NEVER OPERATE HOIST WITHOUT THE PROTECTION OF PROPERLY FUNCTIONING LIMIT SWITCHES.

INSTRUCTIONS FOR 4-PART DOUBLE REEVED HOISTS ONLY: REFER TO FIGURE 30

6. Remove top running sheaves to release wire rope.
7. Remove equalizing sheave from sheave hanger to release wire rope.
8. Install and reeve new wire rope as follows:
 - a. Loop center of wire rope around equalizing sheave and reassemble equalizing sheave into sheave hanger.
 - b. Insert one end of the wire rope from the equalizing sheave through the gravity limit switch weight.
 - c. Working with only one end of the wire rope from the equalizing sheave, eliminate any twist, and reeve around one inner load block sheave, one top running sheave, and one outer load block sheave.

WIRE ROPE

- d. Reassemble load block cover over sheave.
- e. Insert button end of wire rope into drum opening after eliminating any twist between load block and drum.
- f. Repeat steps c, d, and e with the other end of the wire rope from the equalizing sheave.
- g. **WEARING PROTECTIVE GLOVES OR OTHER HAND PROTECTION DEVICES, AND KEEPING HANDS WELL AWAY FROM THE DRUM**, guide the wire ropes into the drum grooves while operating the hoist in the lifting direction.
NOTE: An assistant is required to either operate hoist or guide ropes during this procedure.

CAUTION

WHEN GUIDING THE WIRE ROPE INTO THE DRUM GROOVES, USE ONLY A LIGHT SQUEEZING PRESSURE. DO NOT SQUEEZE ROPE THAT WILL ALLOW HAND BEING PULLED INTO THE GROOVES AND ROPE. KEEP HANDS WELL POSITIONED AWAY FROM DRUM. ALWAYS WEAR GLOVES OR OTHER HAND PROTECTION DEVICES WHEN HANDLING WIRE ROPE. NEVER HANDLE MOVING WIRE ROPE WITH BARE HANDS.

- h. Reset the lower limit of the geared limit switch, if provided.
- i. Test all limit switches before returning the hoist to regular service.

WARNING

NEVER OPERATE HOIST WITHOUT THE PROTECTION OF PROPERLY FUNCTIONING LIMIT SWITCHES.

CAUTION

CERTAIN PRECAUTIONS SHOULD BE TAKEN WHEN THE HOIST IS NOT IN USE.

1. Position load block at a height that will minimize personnel from walking into the block. It is recommended that the block be positioned at a height of at least seven feet above the floor level when not in use.
2. Always anchor outdoor hoists or cranes when not attended or not in use. The load block makes a convenient means to be used in the anchoring process.
3. Always disconnect power to a hoist or crane when not in use.

UNIVERSAL JOINTS

FIGURE 31

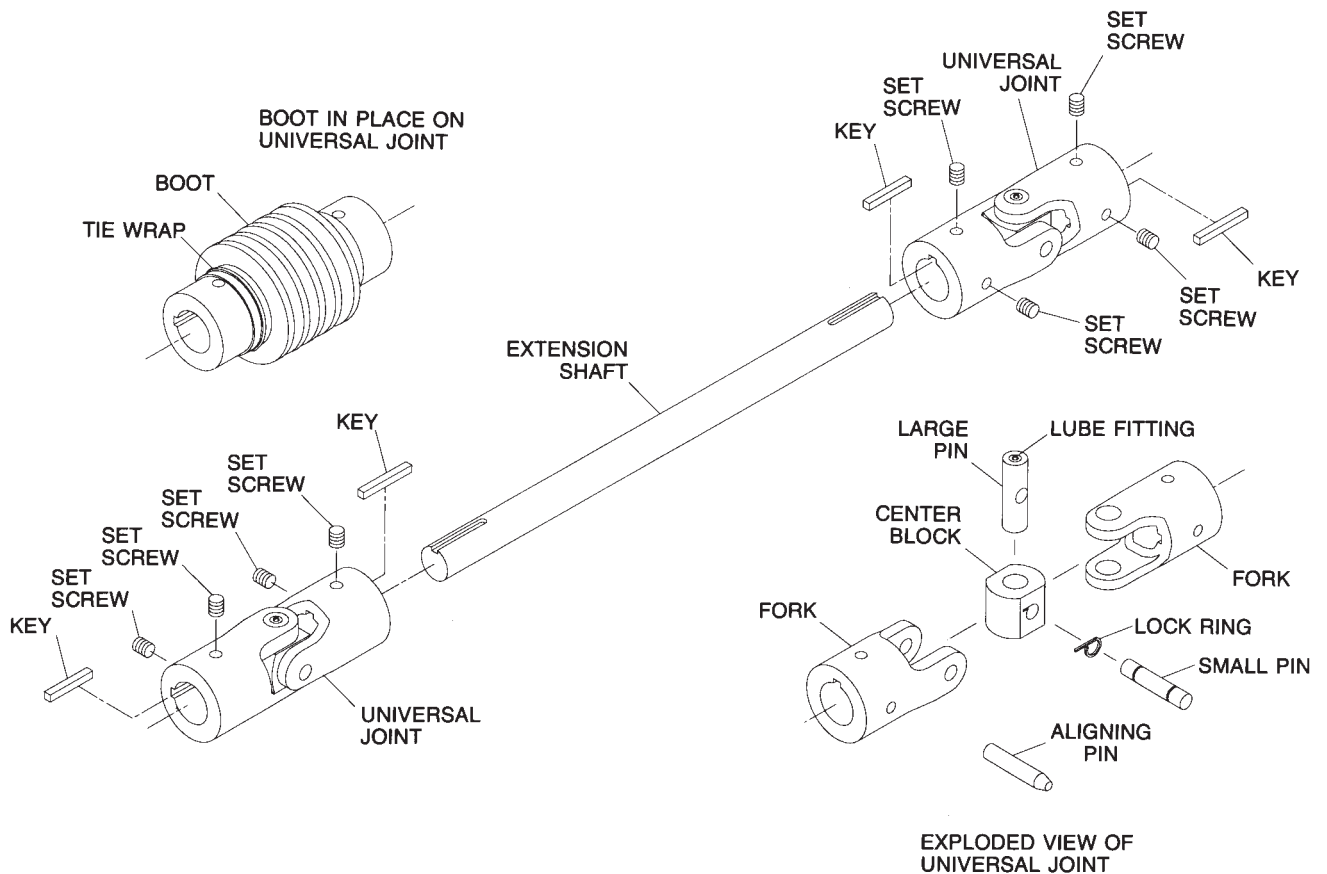

Cross mounted hoists utilize universal joints. Removal of universal joints does not require removal of the motor. Removal of universal joints without removal of the motor requires disassembly of at least one of the universal joints. To disassemble one or both of the universal joints, refer to Figure 31 and use one of the following two sets of instructions.

TO DISASSEMBLE ONE UNIVERSAL JOINT ONLY:

1. Follow the procedures and instructions listed in the MAINTENANCE AND INSPECTION PROCEDURES section of this manual.
2. Remove the two tie wraps from the universal joint boot. Slide the boot onto the extension shaft.
3. If necessary, rotate the extension shaft so that the small diameter pin is in a position in which it can be driven out. This may require re-energizing the hoist and pressing the up or down button as appropriate.

⚠ WARNING

KEEP HANDS AND TOOLS AWAY FROM THE EXPOSED UNIVERSAL JOINT AND THE EXTENSION SHAFT WHEN OPERATING THE HOIST.

DISCONNECT POWER FROM THE HOIST AND LOCKOUT DISCONNECTING MEANS BEFORE CONTINUING WITH DISASSEMBLY.

4. Support the extension shaft with a sling near the end of the shaft which mates with the universal joint to be disassembled. Support should be such that the extension shaft will not fall when the universal joint is disengaged.

UNIVERSAL JOINTS

5. The small diameter pin should now be in an accessible position. Support the universal joint and press out the small diameter pin, being careful not to lose the lock ring which is in the recess of the center block.
6. Once the small diameter pin is removed, the lock ring, the large diameter pin, and the center block can be removed. The forks will remain attached to the extension shaft and the adjoining shaft (motor shaft or motor pinion shaft depending on the end of hoist being worked on). The extension shaft will now be solely supported by the sling and the universal joint on the other end of the shaft.
7. Loosen the set screws and remove the forks and the keys from the shafts they are attached to. To remove the forks, it will be necessary to tilt the extension shaft away from the adjoining shaft.
8. Slide the boot from the extension shaft. The universal joint is now totally disassembled and totally removed from the shafts it joined.

TO DISASSEMBLE BOTH UNIVERSAL JOINTS:

1. Follow the procedures and instructions listed in the MAINTENANCE AND INSPECTION PROCEDURES section of this manual.
2. Remove the two tie wraps from each of the universal joint boots. Slide the boots onto the extension shaft.
3. If necessary, rotate the extension shaft so that the small diameter pin in each universal joint is in a position in which it can be driven out. This may require re-energizing the hoist and pressing the up or down button as appropriate.

WARNING

KEEP HANDS AND TOOLS AWAY FROM THE EXPOSED UNIVERSAL JOINTS AND THE EXTENSION SHAFT WHEN OPERATING THE HOIST.

DISCONNECT POWER FROM THE HOIST AND LOCKOUT DISCONNECTING MEANS BEFORE CONTINUING WITH DISASSEMBLY.

4. Support the extension shaft with a sling near each end of the shaft. Support should be such that the extension shaft will not fall when the universal joints are disengaged.
5. The small diameter pin in each universal joint should now be in an accessible position. Start with one universal joint. Support the joint and press out the small diameter pin, being careful not to lose the lock ring which is in the recess of the center block.
6. Once the small diameter pin is removed, the lock ring, the large diameter pin, and the center block can be removed. The forks will remain attached to the extension shaft and the adjoining shaft (motor shaft or motor pinion shaft depending on the end of hoist being worked on). The extension shaft will now be solely supported by the slings and the universal joint on the other end of the shaft.
7. Repeat steps 5 and 6 for the other universal joint. Do not mix parts between the two universal joints. The extension shaft will now be solely supported by the slings.
8. Loosen the set screws and remove the forks and the keys from the shafts they are attached to. To remove the forks, it will be necessary to move the loose extension shaft away from the adjoining shafts.
9. Slide the boots from the extension shaft. The universal joints are now totally disassembled and totally removed from the shafts they joined.

UNIVERSAL JOINTS

FIGURE 32

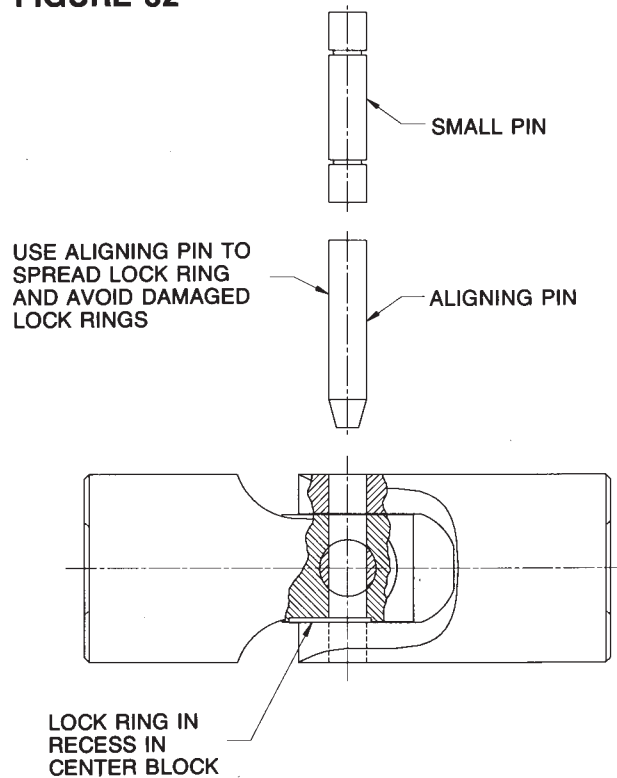

TO REASSEMBLE UNIVERSAL JOINTS:

1. Follow the procedures and instructions listed in the MAINTENANCE AND INSPECTION PROCEDURES section of this manual.
2. Support extension shaft with sling(s).
3. Slide boots onto extension shaft.
4. Insert keys into shaft keyways and slide forks onto shafts.
5. If possible, rotate the shafts so that the small diameter pins will be in the most accessible position when parts will be assembled.
6. Starting with one universal joint, mount parts as shown in Figures 31 and 32, making sure lock ring is in its recess in the center block. As shown in Figure 32, insert a pointed aligning pin into the small hole and push it through, following with the small pin which will automatically lock itself into place. A pointed aligning pin can be obtained by ordering Acco part number 70840. If a grease gun is not available (see step 9) to lubricate the joint after assembly, the contact surfaces of the pins, center block and forks should be greased before assembly.
7. Repeat step 6 for the other universal joint.
8. Equalize the spaces between the three shafts and the center blocks of the two universal joints. Make sure keys do not extend into the spaces between the shafts and the center blocks (this would indicate keys are not fully engaged). Then insert set screws into the forks and tighten them. Application of Loctite Threadlocker Adhesive on set screws is recommended.
9. Lubricate universal joints by injecting Lyondell EP Moly D Grease into the large pin via the lube fitting in the end of the pin. Grease should also be applied to the external surfaces of the center block and the pins (especially where they engage the forks). Containers of Lyondell EP Moly D Grease, packaged in a 4-ounce squeeze bottle, can be obtained by ordering Acco part number 69807.
10. Slide boots onto the universal joints, center them on the joints, and secure with commonly available tie wraps. Pull the tie wraps tight with a pliers and snip off the excess. Failure to pull the tie wraps tight may result in boot migration.

UNIVERSAL JOINTS

Universal joints can be removed intact. Removal of universal joints intact requires removal of the motor. To remove the universal joints intact, refer to Figure 31 and use the following set of instructions.

TO REMOVE UNIVERSAL JOINTS INTACT:

1. Follow the procedures and instructions listed in the MAINTENANCE AND INSPECTION PROCEDURES section of this manual.
2. Remove the two tie wraps from each of the universal joint boots. Slide the boots onto the extension shaft.
3. Support the extension shaft with a sling near each end of the shaft. Support should be such that the extension shaft will not fall when the universal joints are removed.
4. Start with the universal joint nearest the motor. Loosen the set screws which secure the universal joint to the motor shaft.
5. Support the motor with a sling. Loosen and remove the motor bolts and lockwashers. Remove the motor.
6. Loosen the set screws which secure the universal joint to the extension shaft. Remove the universal joint closest to the motor by sliding it off of the extension shaft.
7. Loosen the set screws which secure the other universal joint to the extension shaft. Remove the extension shaft by sliding it out of the universal joint. Slide the boots off of the extension shaft.
8. Loosen the set screws which secure the universal joint to the motor pinion shaft. Remove the universal joint by sliding it off of the motor pinion shaft.
9. Universal joints are now removed intact. Keys can be removed from the shafts if desired.

TO INSTALL UNIVERSAL JOINTS INTACT:

1. Follow the procedures and instructions listed in the MAINTENANCE AND INSPECTION PROCEDURES section of this manual.
2. Slide boots onto extension shaft.
3. Insert keys into shaft keyways.
4. Slide universal joint onto motor pinion shaft.
5. Support the extension shaft with a sling near each end of the shaft. Slide the extension shaft into the universal joint.
6. Slide the second universal joint onto the other end of the extension shaft.
7. Install the motor by sliding the motor shaft into the second universal joint and installing and tightening the motor bolts and lockwashers. The extension shaft is now supported by the two universal joints.
8. Equalize the spaces between the three shafts and the center blocks of the two universal joints. Make sure keys do not extend into the spaces between the shafts and the center blocks (this would indicate keys are not fully engaged). Then insert set screws into the forks of the universal joints and tighten them. Application of Loctite Threadlocker Adhesive on set screws is recommended.
9. Lubricate universal joints by injecting Lyondell EP Moly D Grease into the large pin via the lube fitting in the end of the pin. Grease should also be applied to the external surfaces of the center block and the pins (especially where they engage the forks). Containers of Lyondell EP Moly D Grease, packaged in a 4-ounce squeeze bottle, can be obtained by ordering Acco part number 69807.
10. Slide boots onto the universal joints, center them on the joints, and secure with commonly available tie wraps. Pull the tie wraps tight with a pliers and snip off the excess. Failure to pull the tie wraps tight may result in boot migration.

TROLLEYS

Trolleys specified for the WRIGHT® WORK-RATED® hoist line include:

- Plain under-running trolleys
- Hand-gearred under-running trolleys
- Motor-driven under-running trolleys
- Hand-gearred top-running trolleys
- Motor-driven top-running trolleys

Two types of gear drive units are used on motor-driven trolleys. The majority of motor-driven trolleys use a right-angle worm gear reducer unit. Some motor-driven trolleys may use the Acco® WRIGHT® No. 1 flange-mounted reducer unit. Refer to the instructions that apply to the type of reducer supplied with the trolley.

Motor brakes are optional on motor-driven trolleys that use a right-angle worm gear reducer unit, and are only furnished when specified. Motor brakes are specified as standard on motor-driven trolleys that use the Acco® WRIGHT® No. 1 flange-mounted gear reducer unit.

The brake coil on reconnectable 230/460 volt single-speed motors may be connected for 230 volts or 460 volts. The brake coil must be reconnected as shown in Figure 33 if the motor voltage is reconnected.

FIGURE 33

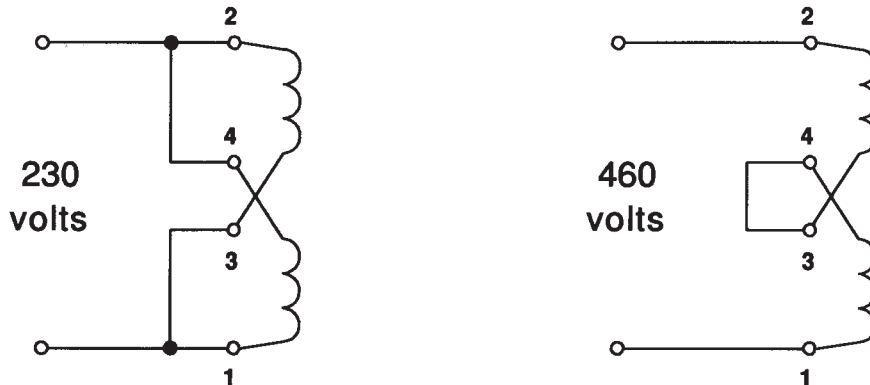

The trolley brake (if specified) on hoists in regular service should be checked without load on the hook by the operator at the start of each shift, or the first time the hoist is to be operated during each shift. The trolley brake should be checked during scheduled frequent and periodic inspections.

During daily, frequent, or periodic inspections, the trolley brake should be checked as follows:

1. Operate trolley in both travel directions, without load on the hook, and stop motion to check operation of the trolley brake. The drift of the trolley should not exceed a distance equal to 10% of the trolley travel speed in either direction. If trolley drift exceeds this distance, the motor brake normally requires adjustment or lining replacement.
2. After completing trolley brake adjustment or lining replacement, operate trolley in both travel directions, without load on the hook, and stop motion to check operation of the trolley brake. If trolley drift is still excessive, replace the brake assembly.



DISCONNECT POWER AND LOCKOUT DISCONNECTING MEANS BEFORE ADJUSTING MOTOR BRAKE.

Only qualified personnel should adjust brakes.

TROLLEYS

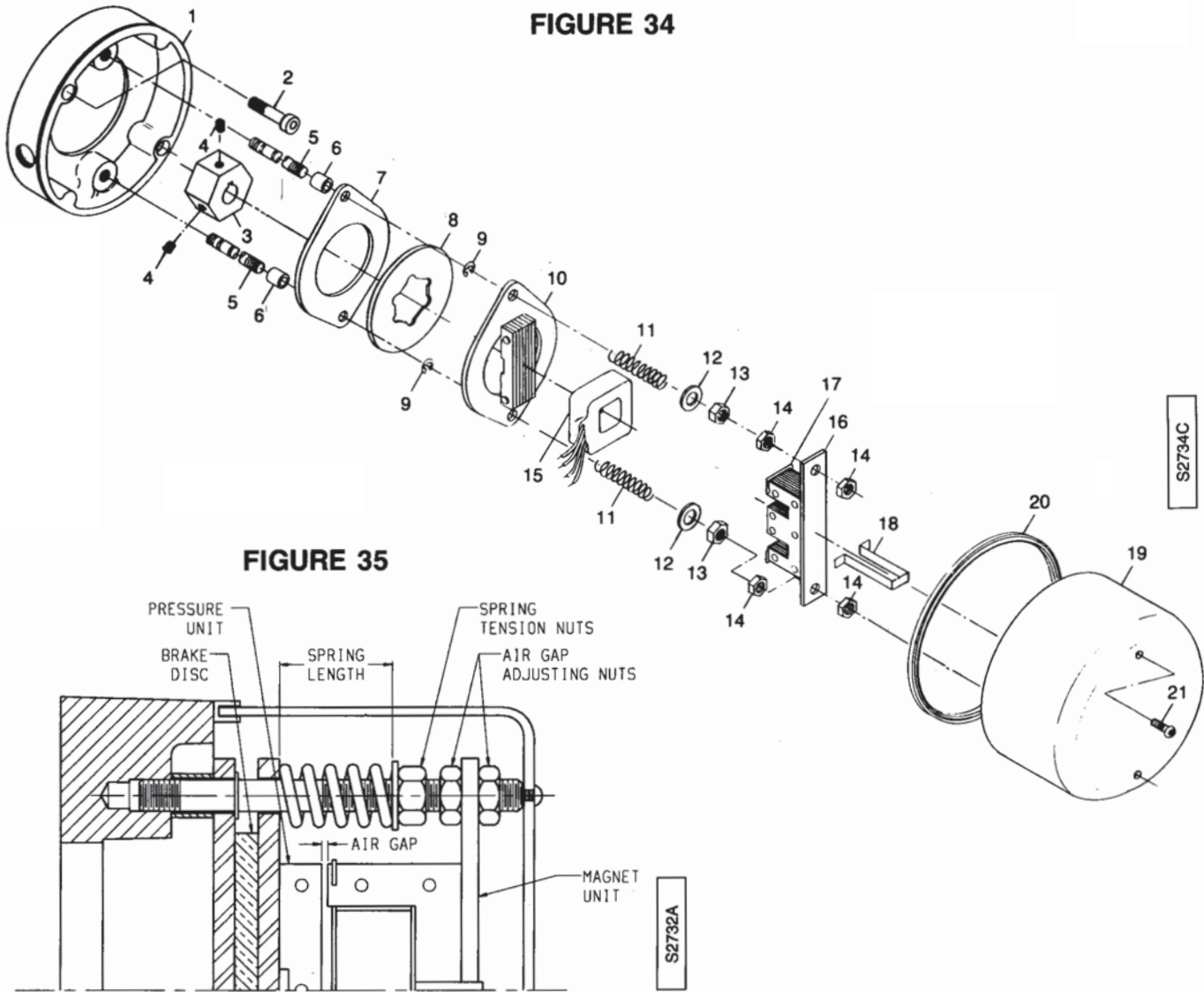

TROLLEY MOTOR BRAKE INSPECTION:

The trolley motor brake and parts are shown in Figures 34 and 35. Trolley motor brake should be inspected every three months, and during scheduled frequent and periodic inspections, as follows:

1. Follow the procedures and instructions listed in the MAINTENANCE AND INSPECTION PROCEDURES section of this manual.
2. Loosen and remove bolts (21) securing brake cover (19).
3. Remove brake cover (19).
4. Use brush or rag to remove any lining dust that has accumulated on brake parts. Specific attention should be directed to removal of dust from the air gap between magnet unit (16) and armature plate (10).

⚠ WARNING

USE PROPER EYE AND BREATHING PROTECTION EQUIPMENT DURING DUST REMOVAL.

TROLLEYS

5. Check brake coil (15) for proper fit and retention in magnet unit (16). Adjust coil strap (18) to tighten.
6. Check for loose electrical connections or broken wires. Repair or replace as required.
7. Check thickness of brake disc (8). Replace disc if worn to a thickness of 3/32 inch (2.4 mm) or less.
8. Check air gap and adjust if required.
Minimum air gap - 0.020 inch (0.5 mm)
Maximum air gap - 0.045 inch (1.1 mm)
Adjust in accordance with "TO ADJUST AIR GAP" instructions of this section.
9. Replace brake cover (19) and secure with bolts (21). Bolts (21) are self-locking type with locking insert. Do not reuse bolts with damaged locking insert or that do not tighten properly. When replacing the brake cover, the ends of the rubber gasket should face downward to prevent water or foreign substances from getting inside the brake cover.

TO ADJUST AIR GAP:

Adjust trolley motor brake air gap as follows:

1. Loosen the air gap adjusting nuts (14) to allow the magnet unit (16) to move toward the pressure unit (10). Using a feeler gage, set the air gap to 0.020 inches. Tighten air gap adjusting nuts (14) to lock the position on the magnet unit (16). Check air gap at several points to verify uniform setting.
2. As brake disc wear occurs, the compressed length of spring (11) will increase. Select the recommended compressed spring length from Table 22, based on trolley motor horsepower. Adjust both spring lengths in accordance with Table 22 plus or minus 1/32 inch. If trolley stopping performance is not satisfactory, increase compressed spring length for less brake torque or decrease compressed spring length for more brake torque.

TABLE 22
COMPRESSED LENGTH OF SPRING
TROLLEY MOTOR BRAKE

MOTOR HORSEPOWER 1800	BRAKE TORQUE (LB FT)	COMPRESSED LENGTH SPRING (IN)
1/2	3/4	1-5/8
3/4	1-1/8	1-9/16
1	1-1/2	1-1/2

TROLLEY INSPECTION:

The trolley should be inspected every three months, and during scheduled frequent and periodic inspections, as follows:

1. Follow the procedures and instructions listed in the MAINTENANCE AND INSPECTION PROCEDURES section of this manual.
2. Inspect trolley wheel bearings for wear by manually rotating and rocking wheels. If excessive bearing play is present, replace bearings.
3. Inspect for wear, flat spots, or damage to wheel tread; and cracked or broken wheel flanges. Replace wheels as required. When wheel replacement is required, all the wheels of a trolley should be replaced.
4. Inspect gear teeth of geared wheels and pinion for wear, cracks, or damage. Replace geared wheels or pinion as required. Geared wheels should always be replaced in pairs.
5. Inspect and tighten or replace as required all bolts, nuts, and locking devices.
6. Check lubrication in accordance with the LUBRICATION section of this manual.

TROUBLESHOOTING

If hoist operates erratically, or not at all, the hoist should be taken out of service. Any problem should be diagnosed and corrected before the hoist is returned to regular service. Refer to Table 23 for some problem areas to consider and investigate.

 **DANGER**

DISCONNECT POWER AND LOCKOUT DISCONNECTING MEANS BEFORE PERFORMING SERVICE TO ELECTRICAL PARTS OF THIS EQUIPMENT.

Only a qualified electrician should perform service to electrical parts of this equipment.

TABLE 23

PROBLEM	POSSIBLE CAUSE	CORRECTIVE ACTION
Hoist will not operate.	Power failure in power lines.	Check circuit breakers, switches, and connections in power lines.
	Low voltage or frequency.	Check voltage and frequency, or power supply. They must agree with data on nameplate.
	Hoist overload cutoff has tripped.	Reduce load to within rated capacity of hoist.
	Motor overheated. (Thermostat or thermal overload relays have tripped.)	Refer to motor or brake overheating problem area. Check thermostat or thermal overloads.
	Improper, loose, or broken wire connection.	Check connections and lead wires. Check connections in control devices.
	Brake does not release.	Check connections to magnet coil. Check for open or short circuit.
	Magnetic contactor not operating.	Check coil for open or short circuit. Check all connections in control circuit. Check for open contact. Replace as needed.
	Control transformer damaged.	Check transformer fuse. Check transformer coil. Check transformer for open winding.
	Motor burned out.	Replace motor.
Hook moves in wrong direction.	Reverse phasing.	Interchange any two power supply line leads.
	Improper electrical connections.	Check all connections with wiring diagram.

TROUBLESHOOTING

TABLE 23 (CONTINUED)

PROBLEM	POSSIBLE CAUSE	CORRECTIVE ACTION
Hook lifts but will not lower.	<p>Lowering circuit open.</p> <p>Broken conductor in pendant cable.</p> <p>Magnetic contactor not operating.</p>	<p>Check circuit for loose connections. Check lower limit switch (if provided).</p> <p>Check continuity of each conductor in the cable. If one is broken, replace cable.</p> <p>Check coil for open or short circuit. Check all connections in motor circuit. Check for burned contacts. Replace as needed.</p>
Hook lowers but will not lift.	<p>Hoist overload cutoff has tripped.</p> <p>Low voltage.</p> <p>Lifting circuit open.</p> <p>Broken conductor in pendant cable.</p> <p>Magnetic contactor not operating.</p>	<p>Reduce load to within rated capacity of hoist.</p> <p>Determine cause of low voltage and correct to within 10% of specified name plate voltage. Measure voltage at hoist contactor.</p> <p>Check circuit for loose connections. Check upper limit switch.</p> <p>Check continuity of each conductor in the cable. If one is broken, replace cable.</p> <p>Check coil for open or short circuit. Check all connections in motor circuit. Check for burned contacts. Replace as needed.</p>
Hoist will not lift rated load or does not have proper lifting speed.	<p>Hoist overloaded.</p> <p>Low voltage.</p> <p>Hoist motor brake dragging.</p>	<p>Reduce load to within rated capacity of hoist.</p> <p>Determine cause of low voltage and correct to within 10% of specified name plate voltage. Measure voltage at hoist contactor.</p> <p>Check motor brake adjustment for proper clearance and magnet mounting for proper location and tightness.</p>

TROUBLESHOOTING

TABLE 23 (CONTINUED)

PROBLEM	POSSIBLE CAUSE	CORRECTIVE ACTION
Hook or load drifts excessively when hoist is stopped.	<p>Hoist motor brake not holding.</p> <p>Hoist mechanical brake not holding.</p>	<p>Inspect and check hoist motor brake as outlined in MOTOR BRAKE section of this manual.</p> <p>Inspect and check mechanical load brake as outlined in MECHANICAL LOAD BRAKE section of this manual.</p>
Hoist motor or motor brake overheating.	<p>Hoist overloaded.</p> <p>Excessive duty cycle.</p> <p>Wrong voltage or frequency.</p> <p>Hoist motor brake dragging.</p> <p>Extreme external heating.</p>	<p>Reduce load to within rated capacity of hoist.</p> <p>Reduce frequency of lifts.</p> <p>Check voltage and frequency of power supply. They must agree with data on nameplate.</p> <p>Check motor brake adjustment for proper clearance and magnet mounting for proper location and tightness.</p> <p>If ambient temperature exceeds 100° F, frequency of hoist operation must be limited to avoid overheating. Special provisions may be required to ventilate the hoist or shield it from the heat source.</p>
Hook or load accelerates during lowering.	<p>Hoist mechanical load brake slipping.</p> <p>Hoist mechanical load braking not operating.</p>	<p>Check mechanical load brake lining.</p> <p>Check mechanical load brake pawl and ratchet for proper engagement or for damage. Check ratchet bushing for wear. Replace parts as necessary.</p>
Hoist operates intermittently.	<p>Poor collector contact.</p> <p>Broken wires.</p> <p>Worn contacts.</p>	<p>Check for dirt or foreign matter on, and wear of, contact surfaces. Clean or replace as necessary.</p> <p>Check wiring. Replace any broken wires.</p> <p>Locate and replace worn or burnt contacts.</p>

TROUBLESHOOTING

TABLE 23 (CONTINUED)

PROBLEM	POSSIBLE CAUSE	CORRECTIVE ACTION
Excessive wire rope wear.	Inadequate lubrication	Replace wire rope and lubricate.
	Side-pulling or abuse.	Replace wire rope and avoid improper operation.
Oil leaks.	Worn or damaged gaskets and/or oil seals.	Replace worn or damaged parts.
	Joints not tight.	Tighten bolts to recommended torque.
Hoist motor will not start.	Hoist motor brake not released.	Inspect and check hoist motor brake as outlined in MOTOR BRAKE section of this manual.
Hoist motor will not start even though hoist motor brake releases.	Damaged contacts within interlocking switch of hoist motor brake.	Replace interlocking switch as outlined in MOTOR BRAKE section of this manual.
Trolley brake does not release.	Power failure in power lines.	Check circuit breakers, switches, and connections in power lines.
	Improper, loose, or broken wire connection.	Check connections and lead wires. Check connections in control devices.
	Wrong voltage or frequency.	Check voltage and frequency of power supply. They must agree with data on nameplate.
	Broken or damaged parts.	Inspect and replace parts as necessary.
	Coil burned out.	Replace coil.
Trolley brake does not stop.	Trolley motor brake not holding.	Inspect and check trolley motor brake as outlined in TROLLEYS section of this manual.
Trolley brake chatters or hums.	Magnet faces not clean or broken shading coil on magnet.	Clean magnet surface and replace shading coils if broken.
Trolley does not track on beam or bumps as it travels on beam.	Excessive wear of trolley wheel treads or flat spots on trolley wheel treads.	Inspect trolley wheels and replace as necessary.

TYPICAL WIRING DIAGRAM

SINGLE SPEED HOIST & SINGLE SPEED TROLLEY

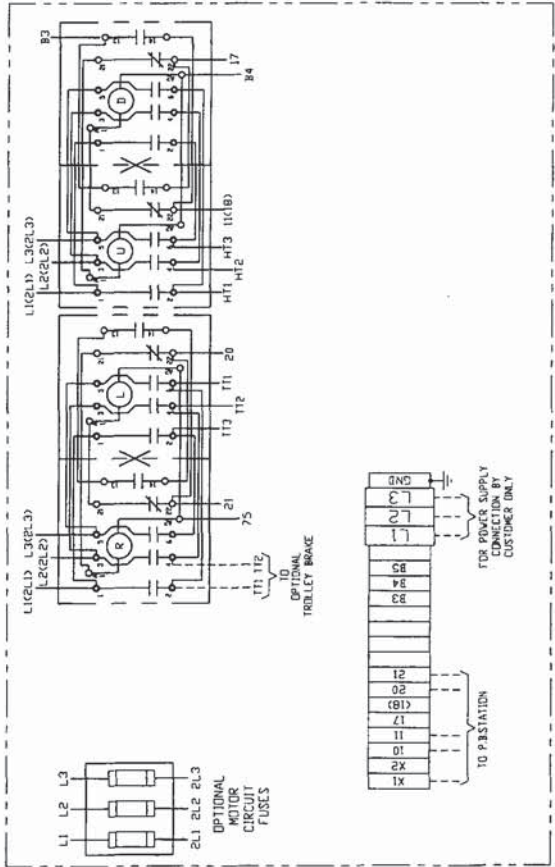
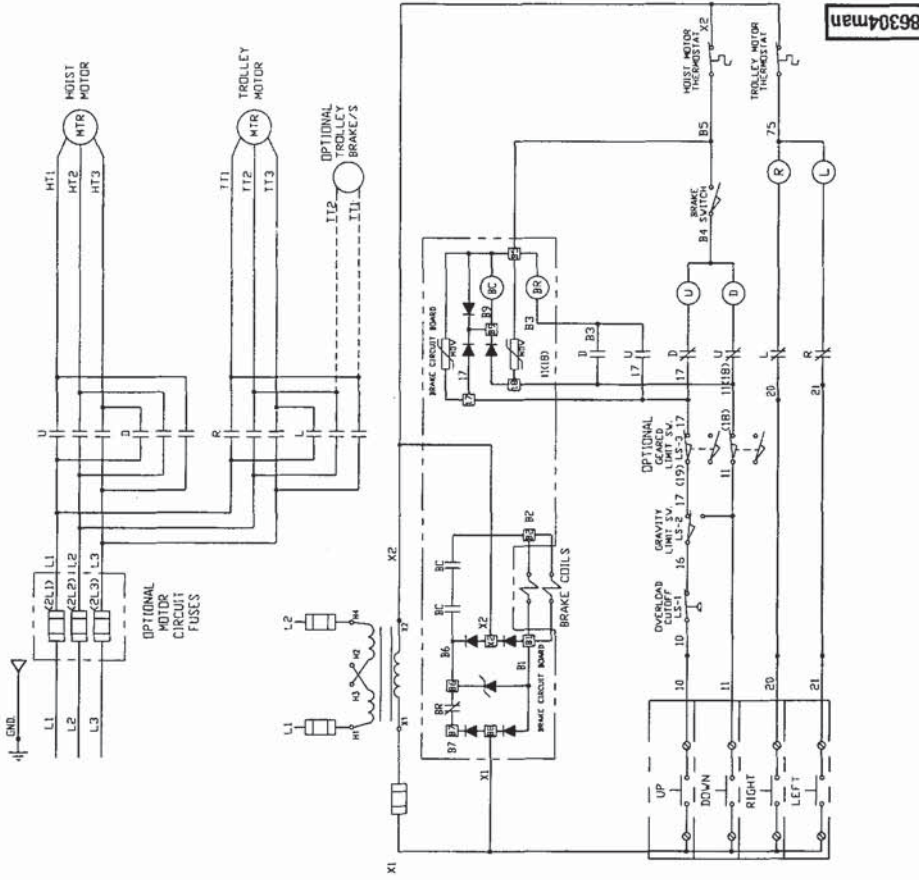

HOIST AND TROLLEY CONTROL PANEL

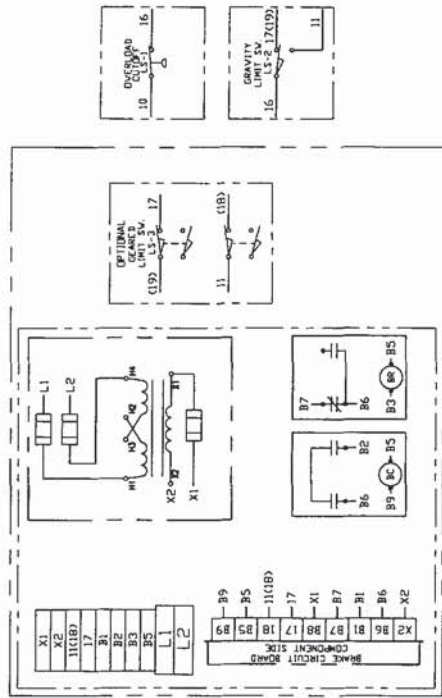

BRAKE AND LIMIT SWITCH CONTROL PANEL

CAUTION

WIRING DIAGRAMS SHOWN ARE "TYPICAL" AND MAY NOT INCLUDE ALL DEVICES SUPPLIED WITH A PARTICULAR HOIST OR TROLLEY. ALWAYS REFER TO THE WIRING DIAGRAM SUPPLIED INSIDE OF THE CONTROL ENCLOSURE COVER OF A SPECIFIC PIECE OF EQUIPMENT, BEFORE PERFORMING ANY SERVICE.

DANGER

DISCONNECT POWER AND LOCKOUT DISCONNECTING MEANS BEFORE REMOVING COVER OR SERVICING THIS EQUIPMENT. SERVICE SHOULD BE PERFORMED ONLY BY A QUALIFIED ELECTRICIAN.

86304man

TYPICAL WIRING DIAGRAM

TWO SPEED HOIST & TWO SPEED TROLLEY

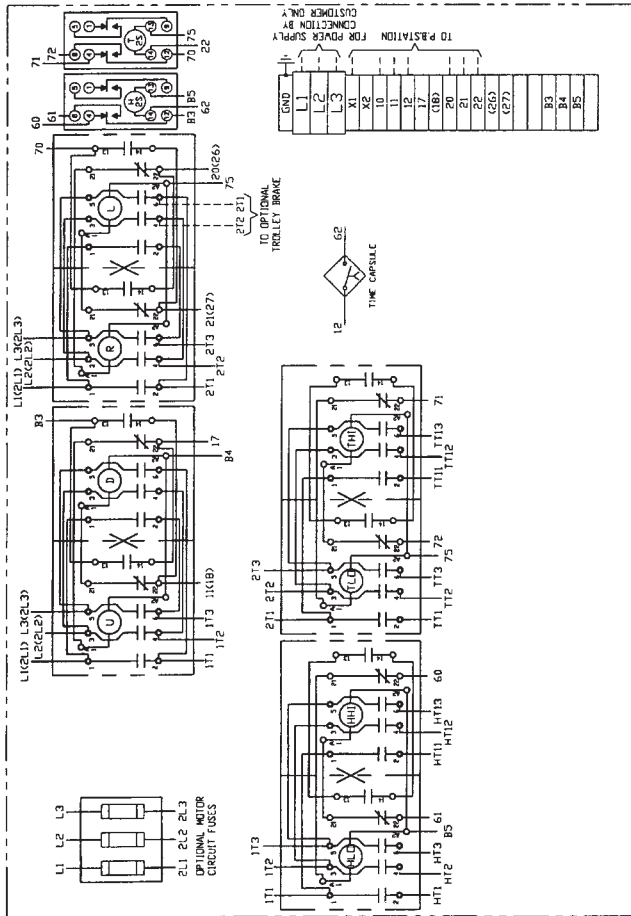
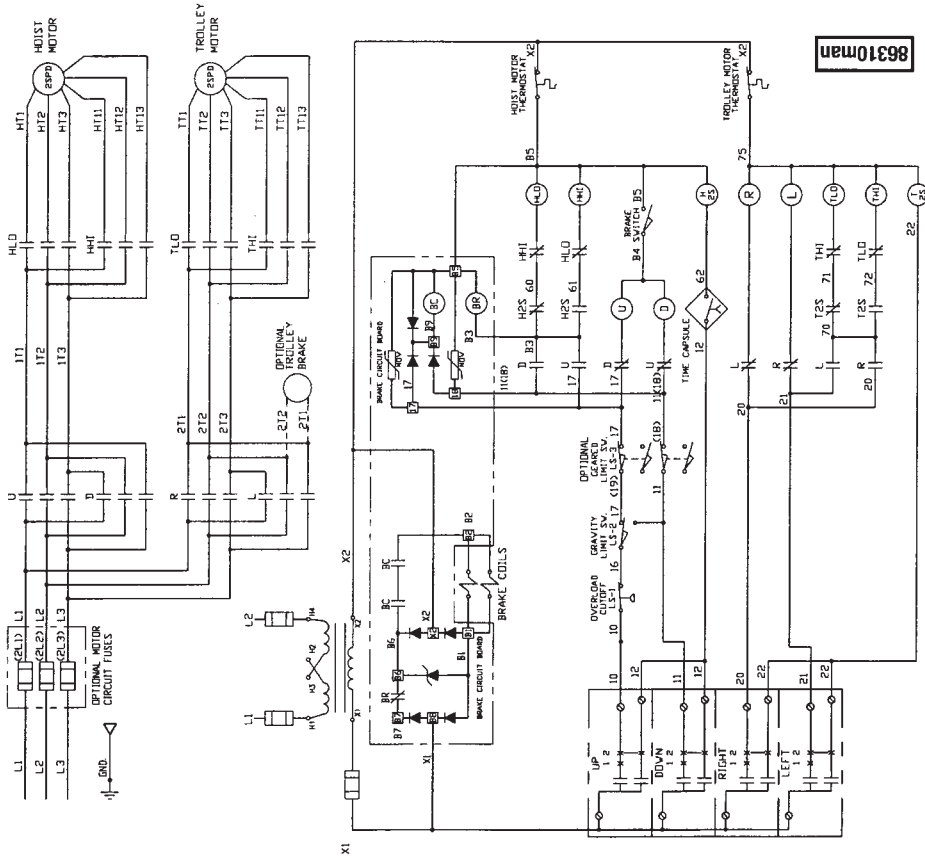

HOIST AND TROLLEY CONTROL PANEL

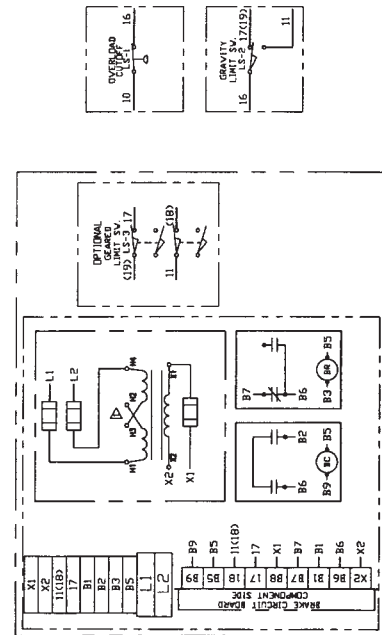

BRAKE AND LIMIT SWITCH CONTROL PANEL

CAUTION

WIRING DIAGRAMS SHOWN ARE "TYPICAL" AND MAY NOT INCLUDE ALL DEVICES SUPPLIED WITH A PARTICULAR HOIST OR TROLLEY. ALWAYS REFER TO THE WIRING DIAGRAM SUPPLIED INSIDE OF THE CONTROL ENCLOSURE COVER OF A SPECIFIC PIECE OF EQUIPMENT, BEFORE PERFORMING ANY SERVICE.

DANGER

DISCONNECT POWER AND LOCKOUT DISCONNECTING MEANS BEFORE REMOVING COVER OR SERVICING THIS EQUIPMENT. SERVICE SHOULD BE PERFORMED ONLY BY A QUALIFIED ELECTRICIAN.

GENERAL CONDITIONS OF WARRANTY

WARRANTIES: The Seller warrants to the original using Buyer thereof that the goods sold under this Agreement are free from defects in workmanship and materials for a period of two years from the date of shipment to the original using Buyer. No other express warranties are given and no affirmation of Seller or Seller's agents, by word or action, shall constitute a warranty. No warranty is made for components and accessories made by others when such items are warranted by their respective manufacturers.

Installation or operation of the equipment in any manner other than as recommended by Seller, shall void the warranty.

Storage of the equipment in any manner other than as recommended by Seller, shall void the warranty. Contact Seller for storage procedure.

Any variations in details between the goods furnished herein and those covered in Buyer's specifications are due to standards of manufacture not to be construed as exceptions to the specifications.

DISCLAIMER OF IMPLIED WARRANTIES:

- (a) SELLER MAKES NO WARRANTY OF MERCHANTABILITY IN RESPECT TO THE GOODS SOLD UNDER THIS AGREEMENT.
- (b) This sale is made WITHOUT ANY WARRANTY BY SELLER THAT THE GOODS ARE SUITABLE FOR ANY PARTICULAR PURPOSE.
- (c) Buyer hereby waives all other warranties, guarantees, obligations, liabilities, rights, and remedies arising by law or otherwise including any obligation or liability of the Seller arising from tort, and Buyer shall indemnify Seller from any liability, loss, damage, or claim arising from Buyer's tortious use of the goods sold hereby.

REMEDIES:

- (a) Under no conditions shall any goods be returned to Seller without its prior written consent.
- (b) The Buyer's sole and exclusive remedy for breach of any warranty is limited to Seller furnishing, at its expense, duplicate or repaired parts F.O.B. Seller's plant with installation at Buyer's expense if discovery of a claimed defect occurs during the allowable warranty period, and if Seller's inspection determines a defect exists.
- (c) The quantity of material shown by invoice shall in all cases govern settlement for shortages, unless notice of shortage, appropriately documented, is given to the carrier and the Seller upon delivery by the Carrier.
- (d) Claims for errors, deficiencies or imperfections shall be deemed waived by the Buyer unless Seller is notified in writing of the basis of such claims within 10 days after discovery of claimed defect and such discovery occurs within the warranted period.
- (e) Neither Buyer nor User shall be entitled under this Agreement to recover from Seller any incidental or consequential damages of any nature including but not limited to the cost of any labor expended by others in connection with the goods sold hereby by reason of any alleged nonconformity or breach of warranty on the part of the Seller, nor costs of material or account thereof, nor any lost profits whether determinable or speculative.



Acco Material Handling Solutions

76 Acco Drive, Box 792 York, PA 17405-0792
717-741-4863 800-967-7333 Fax 800-715-8897
e-mail: info@accomhs.com
www.accomhs.com