

Nutting[®]
CARTS AND TRAILERS

HARRINGTON
A KITO GROUP COMPANY



**Rapid Ship
Carts & Trailers**

Nutting Carts and Trailers

Discover the legacy of Nutting Carts and Trailers, the trusted pioneer in material handling solutions since 1891. With over a century-long commitment to excellence, we have established ourselves as industry leaders in designing and manufacturing top-quality carts and trailers. Located in Watertown, South Dakota, our headquarters serve as the hub of innovation and craftsmanship, delivering exceptional products to businesses across North America.

Nutting Carts and Trailers seamlessly blend tradition and cutting-edge technology to create superior products that stand the test of time. Our comprehensive range includes Rapid Ship items, ready for immediate manufacturing, as well as custom engineered cart and trailer solutions. Whether you require a standard option for quick deployment or a tailored design to meet your specific needs, our team of skilled engineers and sales professionals will deliver a solution that exceeds your expectations.

Our unwavering dedication to customer satisfaction sets us apart. By fostering collaborative partnerships with our clients, we gain deep insights into their challenges and deliver personalized solutions that exceed expectations. Experience the difference that Nutting Carts and Trailers can make for your material handling needs. Join the ranks of countless businesses that have relied on our exceptional quality, unmatched service, and the flexibility to choose from our Rapid Ship items or custom-made carts and trailers.



Rapid Ship Carts and Trailers

Our Rapid Ship line of material handling equipment includes industrial carts, order picker platforms, utility carts, and tugger trailers. Crafted with utmost durability, these high-quality, pre-designed, and approved products eliminate the need for additional engineering time, enabling seamless integration into our production schedule for prompt order fulfillment. With a standard lead time of approximately 30 days from the date of order, we ensure swift delivery, allowing you to get back to work as soon as possible. Choose from our wide range of popular sizes and varieties to find the perfect fit for your specific requirements. We prioritize customer satisfaction, and to ensure the highest quality, we offer a 3-year warranty on all our products. Experience efficiency, reliability, and durable material handling equipment with our Rapid Ship collection manufactured by Nutting Carts and Trailers.



Caster Steer Industrial Cart

The Caster Steer Industrial Cart is a robust and dependable tugger cart designed for efficient material handling in industrial environments. Crafted from durable steel, this cart ensures long-lasting performance, while its auto coupler hitch simplifies attachment and towing, making it compatible with warehouse tuggers. With its excellent maneuverability and agility, the Caster Steer Industrial Cart effortlessly navigates tight spaces and corners, making it ideal for environments with frequent changes in direction. This cart optimizes workflow and enhances overall efficiency, making it the perfect choice for warehouses, manufacturing facilities, and various industrial settings. Experience seamless material handling with our Caster Steer Industrial Cart.

CASTER STEER INDUSTRIAL CART						
Product Code	Size (in.)	Capacity (lbs.)	Steer Type	Wheel Type	Hitch Type	Super Structure
H5200136722WC108H3S0	36x72	2000	Caster	WC1-Rubber	Auto Coupler	N/A
H5200136722WC108H3S1				WC1-Rubber		Push Handle
H5200136722WC308H3S0				WC3-Polyurethane		N/A
H5200136722WC308H3S1				WC3-Polyurethane		Push Handle
H5200136724WC308H3S0	36x72	4000	Caster	WC3-Polyurethane	Auto Coupler	N/A
H5200136724WC308H3S1				WC3-Polyurethane		Push Handle
H5200148962WC108H3S0	48x96	2000	Caster	WC1-Rubber	Auto Coupler	N/A
H5200148962WC108H3S1				WC1-Rubber		Push Handle
H5200148962WC308H3S0				WC3-Polyurethane		N/A
H5200148962WC308H3S1				WC3-Polyurethane		Push Handle
H5200148964WC308H3S0	48x96	4000	Caster	WC3-Polyurethane	Auto Coupler	N/A
H5200148964WC308H3S1				WC3-Polyurethane		Push Handle



5th Wheel Dual Steer Industrial Cart

The 5th Wheel Dual Steer Industrial Cart is a versatile and robust tugger cart designed to handle your material transport needs with ease. Built from durable steel, this cart is capable of withstanding heavy loads and demanding environments. It offers a range of customizable options to perfectly suit your specific requirements. The standout feature of this cart is its 5th wheel steering, which enables exceptional maneuverability and precision, making it the perfect choice for navigating tight spaces and corners. Experience superior control and efficiency with the 5th Wheel Dual Steer Industrial Cart, ensuring smooth operations for your material handling tasks.

5TH WHEEL DUAL STEER INDUSTRIAL CART

Product Code	Size (in.)	Capacity (lbs.)	Steer Type	Wheel Type	Hitch Type
H5400736722WC108H1S0	36x72	2000	Single 5th	WC1-Rubber	Pin & Clevis
H5400736722WC308H1S0				WC3-Polyurethane	Pin & Clevis
H5400736722WK910H1S0				WK9-Solid Pneumatic	Pin & Clevis
H5400736722WC108H2S0				WC1-Rubber	Pintle
H5400736722WC308H2S0				WC3-Polyurethane	Pintle
H5400736722WK910H2S0				WK9-Solid Pneumatic	Pintle
H5400748964WC310H1S0	48x96	4000	Single 5th	WC3-Polyurethane	Pin & Clevis
H5400748964WK916H1S0				WK9-Solid Pneumatic	Pin & Clevis
H5400748964WC310H2S0				WC3-Polyurethane	Pintle
H5400748964WK916H2S0				WK9-Solid Pneumatic	Pintle



5th Wheel Quad Steer Industrial Cart

Our 5th Wheel Quad Steer Industrial Cart is a game-changer in material handling efficiency. This cart is engineered with precision and built to excel in demanding industrial environments. With its innovative quad steering system, featuring a connected pivot point between the front and rear wheels, this cart delivers unparalleled maneuverability, stability, and control. The quad steering enables seamless navigation around tight corners and obstacles, making it ideal for complex industrial settings. Experience the next level of performance and productivity with this tugger compatible cart, revolutionizing the way you handle heavy loads and challenging material transport tasks.

5TH WHEEL QUAD STEER INDUSTRIAL CART

Product Code	Size (in.)	Capacity (lbs.)	Steer Type	Wheel Type	Hitch Type
H5400636722WC108H1S0	36x72	2000	Double 5th	WC1-Rubber	Pin & Clevis
H5400636722WC308H1S0				WC3-Polyurethane	Pin & Clevis
H5400636722WK910H1S0				WK9-Solid Pneumatic	Pin & Clevis
H5400636722WC108H2S0				WC1-Rubber	Pintle
H5400636722WC308H2S0				WC3-Polyurethane	Pintle
H5400636722WK910H2S0				WK9-Solid Pneumatic	Pintle
H5400648964WC310H1S0	48x96	4000	Double 5th	WC3-Polyurethane	Pin & Clevis
H5400648964WK916H1S0				WK9-Solid Pneumatic	Pin & Clevis
H5400648964WC310H2S0				WC3-Polyurethane	Pintle
H5400648964WK916H2S0				WK9-Solid Pneumatic	Pintle

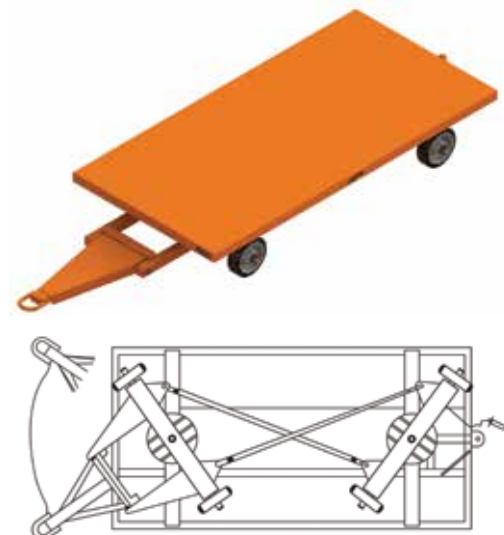

Order Picker Platforms

Introducing our Order Picker Platforms, the ultimate solution for streamlined and efficient order fulfillment. Designed to optimize your order picking operation, these platforms can be ordered in three configurations to suit your specific needs. Choose from a platform for stationary applications, a cart with wheels for easy mobility, or a trailer with wheels and a tow hitch for convenient transportation. With their heavy-duty steel construction, these platforms ensure durability and reliability in demanding environments. They are designed to be easily picked up by either a forklift or an electric order picker, allowing for seamless integration into your existing operations. Experience the perfect blend of flexibility and functionality with our Order Picking Platforms, empowering your team to optimize order picking efficiency and productivity.

ORDER PICKER PLATFORM

Product Code	Size (in.)	Capacity (lbs.)	Super Structure
H2400742482H0S0	42x48	2000	N/A
H2400742482H0S2			Tri Form with Shelves



ORDER PICKER PLATFORM CART

Product Code	Size (in.)	Capacity (lbs.)	Steer Type	Wheel Type	Super Structure
H3500742482WC108H0S2	42x48	2000	Caster	WC1-Rubber	Tri Form with Shelves
H3500742482WC108H0S3				WC1-Rubber	Push Handle
H3500742482WC308H0S3				WC3-Polyurethane	Push Handle
H3500742482WC308H0S2				WC3-Polyurethane	Tri Form with Shelves
H3500742722WC308H0S3	42x72	2000	Caster	WC3-Polyurethane	Push Handle
H3500742722WC308H0S2				WC3-Polyurethane	Tri Form with Shelves
H3500742722WC108H0S2				WC1-Rubber	Tri Form with Shelves
H3500742722WC108H0S3				WC1-Rubber	Push Handle



ORDER PICKER PLATFORM TRAILER

Product Code	Size (in.)	Capacity (lbs.)	Steer Type	Wheel Type	Hitch Type	Super Structure
H5201042722WC108H4S0	42x72	2000	Caster	WC1-Rubber	A-Frame with Hook	N/A
H5201042722WC108H4S3				WC1-Rubber		Push Handle
H5201042722WC308H4S0				WC3-Polyurethane		N/A
H5201042722WC308H4S3				WC3-Polyurethane		Push Handle
H5201048962WC108H4S0	48x96	2000	Caster	WC1-Rubber	A-Frame with Hook	N/A
H5201048962WC108H4S4				WC1-Rubber		Push Handle
H5201048962WC308H4S0				WC3-Polyurethane		N/A
H5201048962WC308H4S4				WC3-Polyurethane		Push Handle



Warehouse Material Handling Products

Introducing our comprehensive range of warehouse material handling products, designed to streamline your operations and maximize efficiency. Our product lineup includes versatile platform trucks and wagons, available in wood, steel, and aluminum configurations to suit your specific requirements. Whether you need the classic durability of wood, the robust strength of steel, or the lightweight maneuverability of aluminum, we have the perfect solution for your material transport needs. With ergonomic designs and sturdy construction, our platform trucks and wagons are built to withstand the demands of a warehouse environment while providing reliable performance. Experience enhanced productivity and seamless material handling with our wide selection of warehouse material handling products, tailored to optimize your workflow and ensure smooth operations.

MEDIUM DUTY WOOD DECK PLATFORM TRUCK

Product Code	Materials	Capacity (lbs.)	Deck Size(in.)	Deck Type	Deck Height (in.)	Total Weight (lbs.)
H31-005-011	Wood & Steel	1600	24 x 36	Hardwood	9.25	85
H31-005-012	Wood & Steel	1600	24 x 48	Hardwood	9.25	95
H31-005-014	Wood & Steel	1600	27 x 54	Hardwood	9.25	105
H31-005-015	Wood & Steel	1600	30 x 60	Hardwood	9.25	120
H31-005-020	Wood & Steel	1600	36 x 72	Hardwood	9.25	150
H31-005-095	Wood & Steel	2000	24 x 48	Hardwood	11.25	115
H31-005-097	Wood & Steel	2000	27 x 54	Hardwood	11.25	130
H31-005-098	Wood & Steel	2000	30 x 60	Hardwood	11.25	150
H31-005-099	Wood & Steel	2000	36 x 72	Hardwood	11.25	180



MEDIUM DUTY TILT STYLE WOOD DECK PLATFORM TRUCK

Product Code	Materials	Capacity (lbs.)	Deck Size (in.)	Deck Type	Deck Height (in.)	Total Weight (lbs.)
H31-006-009	Wood & Steel	900	24 x 48	Hardwood	9.5	110
H31-006-011	Wood & Steel	900	27 x 54	Hardwood	9.5	125
H31-006-012	Wood & Steel	900	30 x 60	Hardwood	9.5	135
H31-006-057	Wood & Steel	1200	24 x 48	Hardwood	11.5	135
H31-006-058	Wood & Steel	1200	27 x 54	Hardwood	11.5	150
H31-006-059	Wood & Steel	1200	30 x 60	Hardwood	11.5	165



WOOD DECK PLATFORM TRUCK WITH WOODEN FRAME

Product Code	Materials	Capacity (lbs.)	Deck Size (in.)	Deck Type	Deck Height (in.)	Total Weight (lbs.)
H31-001-026	Wood & Steel	2400	24x48	Hardwood	14	155
H31-001-028	Wood & Steel	2400	30x60	Hardwood	14	190
H31-001-106	Wood & Steel	2400	36x60	Hardwood	14	200
H31-001-030	Wood & Steel	2400	36x72	Hardwood	14	230
H31-001-102	Wood & Steel	2800	24x48	Hardwood	16	175
H31-001-103	Wood & Steel	2800	30x60	Hardwood	16	210
H31-001-108	Wood & Steel	2800	36x60	Hardwood	16	220
H31-001-104	Wood & Steel	2800	36x72	Hardwood	16	250
H31-001-109	Wood & Steel	4000	30x60	Hardwood	18.5	280
H31-001-110	Wood & Steel	4000	36x72	Hardwood	18.5	315



Warehouse Material Handling Products

HEAVY DUTY TILT STYLE WOOD DECK PLATFORM TRUCK

Product Code	Materials	Capacity (lbs.)	Deck Size (in.)	Deck Type	Deck Height (in.)	Total Weight (lbs.)
H31-002-095	Wood & Steel	1500	24x48	Hardwood	14.5	180
H31-002-104	Wood & Steel	1500	27x54	Hardwood	14.5	200
H31-002-096	Wood & Steel	1500	30x60	Hardwood	14.5	215
H31-002-097	Wood & Steel	1500	36x72	Hardwood	14.5	255
H31-002-098	Wood & Steel	2000	24x48	Hardwood	16.5	195
H31-002-107	Wood & Steel	2000	27x54	Hardwood	16.5	215
H31-002-099	Wood & Steel	2000	30x60	Hardwood	16.5	235
H31-002-100	Wood & Steel	2000	36x72	Hardwood	16.5	270
H31-002-109	Wood & Steel	3000	30x60	Hardwood	19.5	285
H31-002-110	Wood & Steel	3000	36x72	Hardwood	19.5	320



WOOD DECK WITH STEEL FRAME PLATFORM TRUCK

Product Code	Materials	Capacity (lbs.)	Deck Size (in.)	Deck Type	Deck Height (in.)	Total Weight (lbs.)
H35-001-156	Wood & Steel	2400	24x48	Hardwood	12	175
H35-001-157	Wood & Steel	2400	30x60	Hardwood	12	200
H35-001-158	Wood & Steel	2400	36x72	Hardwood	12	235
H35-001-159	Wood & Steel	2800	24x48	Hardwood	14	195
H35-001-160	Wood & Steel	2800	30x60	Hardwood	14	220
H35-001-161	Wood & Steel	2800	36x72	Hardwood	14	255
H35-001-169	Wood & Steel	4000	30x60	Hardwood	18	310
H35-001-170	Wood & Steel	4000	36x72	Hardwood	18	370



STEEL DECK PLATFORM TRUCK

Product Code	Materials	Capacity (lbs.)	Deck Size (in.)	Deck Type	Deck Height (in.)	Total Weight (lbs.)
H33-003-009	Steel	1600	24x36	Steel	9.75	95
H33-003-010	Steel	1600	24x48	Steel	9.75	105
H33-003-011	Steel	1600	27x54	Steel	9.75	120
H33-003-012	Steel	1600	30x60	Steel	9.75	135
H33-003-063	Steel	1600	36x72	Steel	9.75	150
H33-003-013	Steel	2000	24x36	Steel	11.75	105
H33-003-014	Steel	2000	24x48	Steel	11.75	115
H33-003-015	Steel	2000	27x54	Steel	11.75	130
H33-003-016	Steel	2000	30x60	Steel	11.75	145
H33-003-064	Steel	2000	36x72	Steel	11.75	160



ALUMINUM DECK PLATFORM TRUCK

Product Code	Materials	Capacity (lbs.)	Deck Size (in.)	Deck Type	Deck Height (in.)	Total Weight (lbs.)
H33-004-001	Aluminum	1600	24x48	Aluminum	9.75	70
H33-004-007	Aluminum	1600	30x48	Aluminum	9.75	75
H33-004-010	Aluminum	1600	30x60	Aluminum	9.75	80
H33-004-040	Aluminum	1600	36x72	Aluminum	9.75	95
H33-004-013	Aluminum	2000	24x48	Aluminum	11.75	80
H33-004-019	Aluminum	2000	30x48	Aluminum	11.75	85
H33-004-022	Aluminum	2000	30x60	Aluminum	11.75	90
H33-004-041	Aluminum	2000	36x72	Aluminum	11.75	100



ALUMINUM TREAD PLATE PLATFORM TRUCK

Product Code	Materials	Capacity (lbs.)	Deck Size (in.)	Deck Type	Deck Height (in.)	Total Weight (lbs.)
H35-003-046	Aluminum	2000	24x48	Aluminum	12.75	95
H35-003-047	Aluminum	2000	30x60	Aluminum	12.75	105
H35-003-048	Aluminum	2000	36x72	Aluminum	12.75	120
H35-003-049	Aluminum	2800	24x48	Aluminum	12.75	125
H35-003-050	Aluminum	2800	30x60	Aluminum	12.75	140
H35-003-051	Aluminum	2800	36x72	Aluminum	12.75	150



WAGON TRUCK WITH 5TH WHEEL STEERING

Product Code	Materials	Capacity (lbs.)	Deck Size (in.)	Deck Type	Deck Height (in.)	Total Weight (lbs.)
H32-001-014	Wood & Steel	1200	24x48	Hardwood	14	140
H32-001-015	Wood & Steel	1200	30x60	Hardwood	14	190
H36-001-040	Steel	1200	24x48	Steel Edge Lips Up	14	135
H36-001-041	Steel	1200	30x60	Steel Edge Lips Up	14	185
H36-001-042	Steel	1200	24x48	Steel Edge Lips Down	14	135
H36-001-043	Steel	1200	30x60	Steel Edge Lips Down	14	185
H36-001-051	Steel & Particle Board	1200	24x48	Particle Board	14	140
H36-001-055	Steel & Particle Board	1200	30x60	Particle Board	14	190



Custom Carts and Trailers

Discover the perfect solution for your material handling needs with Nutting Carts and Trailers. While our Nutting Rapid Ship program offers a diverse range of products to cater to various warehouse requirements, we understand that some customers may require more specialized solutions. That's why we proudly offer custom engineering services for carts and trailers, ensuring that your unique warehouse needs are met with precision and efficiency. From customized dimensions to specialized features, our team is dedicated to designing the ideal solution for your specific material handling requirements. Experience the flexibility and reliability of Nutting Carts and Trailers, where we go above and beyond to provide tailored solutions for your warehouse operations.



Notes

CONTACT YOUR NEARBY HARRINGTON DISTRIBUTOR

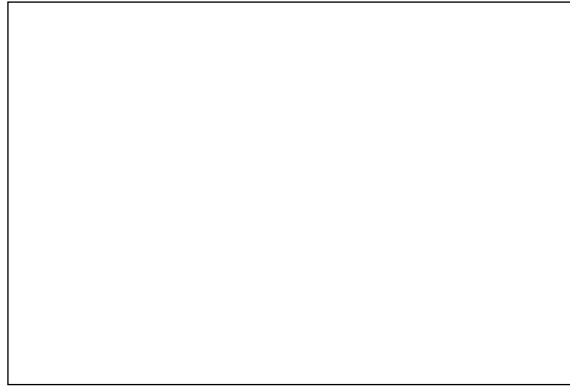

Warranty

All products sold by Harrington Hoists, Inc. are warranted to be free from defects in material and workmanship from date of shipment by Harrington for the following periods:

1 year—Electric and Air Powered Hoists (excluding (N)ER2 Enhanced Features Models, EQ/SEQ Hoists), Powered Trolleys, Powered Tiger Track Jibs and Gantries, Crane Components, Spare/Replacement Parts, Below-The-Hook and Material Handling Equipment

2 years—Manual Hoists & Trolleys, Beam Clamps

3 years—(N)ER2 Enhanced Features Model Hoists, EQ/SEQ Hoists, EM/SEM Hoists, RY Wire Rope Trolley Hoists, Nutting Carts and Trailers

5 years—Manual Tiger Track Jibs and Gantries, TNER, TEM/TSEM, EQ/SEQ and RY Pull-Rotor Motor Brake

10 years—(N)ER2 “The Guardian” Smart Brake

The product must be used in accordance with manufacturer’s recommendations and must not have been subject to abuse, lack of maintenance, misuse, negligence, or unauthorized repairs or alterations.

Should any defect in material or workmanship occur during the above time period in any product, as determined by Harrington Hoist’s inspection of the product, Harrington Hoists, Inc. agrees, at its discretion, either to replace (not including installation) or repair the part or product free of charge and deliver said item F.O.B. Harrington Hoists, Inc. place of business to customer.

Customer must obtain a Return Goods Authorization as directed by Harrington or Harrington’s published repair center prior to shipping product for warranty evaluation. An explanation of the complaint must accompany the product. Product must be returned freight prepaid. Upon repair, the product will be covered for the remainder of the original warranty period. Replacement parts installed after the original warranty period will only be eligible for replacement (not including installation) for a period of one year from the installation date. If it is determined there is no defect, or that the defect resulted from causes not within the scope of Harrington’s warranty, the customer will be responsible for the costs of returning the product.

Harrington Hoists, Inc. disclaims any and all other warranties of any kind expressed or implied as to the product’s merchantability or fitness for a particular application. Harrington will not be liable for death, injuries to persons or property or for incidental, contingent, special or consequential damages, loss or expense arising in connection with the use or inability whatever, regardless of whether damage, loss or expense results from any act or failure to act by Harrington, whether negligent or willful, or from any other reason. Harrington Hoists, Inc. disclaims any and all other warranties of any kind expressed or implied as to the product’s merchantability or fitness for a particular application. Harrington will not be liable for death, injuries to persons or property or for incidental, contingent, special or consequential damages, loss or expense arising in connection with the use or inability whatever, regardless of whether damage, loss or expense results from any act or failure to act by Harrington, whether negligent or willful, or from any other reason.



800-533-0337
hhi@acconutting.com

450 Pheasant Ridge Drive
Watertown, SD 27201

