OWNER'S MANUAL

AIR POWERED CHAIN HOIST TCR SERIES

MODEL TCR

10 Ton and 25 Ton Capacity

Code, Lot and Serial Number

WARNING

This equipment should not be installed, operated or maintained by any person who has not read and understood all the contents of this manual. Failure to read and comply with the contents of this manual can result in serious bodily injury or death, and/or property damage.

HARRINGTON
A KITO GROUP COMPANY

Table of Contents

Section	Page Number
1.0 Important Information and Warnings.....	4
1.1 Terms and Summary	
1.2 Warning Tags and Labels	
2.0 Technical Information.....	8
2.1 Specifications	
2.2 Dimensions	
2.3 Part Names	
3.0 Pre-operational Procedures.....	12
3.1 Air Supply System Requirements	
3.2 Air Supply Capacity And Regulation	
3.3 Lubrication	
3.4 Filtration	
3.5 Air Dryer	
3.6 Piping, Hoses And Fittings	
3.7 Mounting Location	
3.8 Connecting Hoist to Air Supply	
3.9 Mounting the Hoist	
3.10 Non-Stationary Application	
3.11 Preoperational Checks and Trial Operation	
4.0 Operation.....	19
4.1 Introduction	
4.2 Shall's and Shall Not's for Operation	
4.3 Hoist Controls	
4.4 Adjusting the Controls	
4.5 Operation of the Load Limiter	

Section	Page Number
5.0 Inspection.....	24
5.1 General	
5.2 Inspection Classification	
5.3 Frequent Inspection	
5.4 Periodic Inspection	
5.5 Occasionally Used Hoists	
5.6 Inspection Records	
5.7 Inspection Methods and Criteria	
6.0 Lubrication.....	31
6.1 Air Hoist Lubrication	
6.2 Load Chain Lubrication	
6.3 Hooks and Suspension Components	
7.0 Maintenance & Handling.....	32
7.1 Load Limiter	
7.2 Brake	
7.3 Load Chain	
7.4 Pendant	
7.5 Storage	
7.6 Outdoor Installation	
8.0 Troubleshooting.....	38
9.0 Warranty.....	40
9.0 Parts Information.....	41

1.0 Important Information and Warnings

1.1 Terms and Summary

This manual provides important information for personnel involved with the installation, operation and maintenance of this product. Although you may be familiar with this or similar equipment, it is strongly recommended that you read this manual before installing, operating or maintaining the product.

Danger, Warning, Caution and Notice - Throughout this manual there are steps and procedures that can present hazardous situations. The following signal words are used to identify the degree or level of hazard seriousness.

▲ DANGER Danger indicates an imminently hazardous situation which, if not avoided, **will** result in **death or serious injury**, and property damage.

▲ WARNING Warning indicates an imminently hazardous situation which, if not avoided, **could** result in **death or serious injury**, and property damage.

▲ CAUTION Caution indicates a potentially hazardous situation which, if not avoided, **may** result **minor or moderate injury** or property damage.

NOTICE Notice is used to notify people of installation, operation, or maintenance information which is important but not directly hazard-related.

▲ CAUTION

These general instructions deal with the normal installation, operation, and maintenance situations encountered with the equipment described herein. The instructions should not be interpreted to anticipate every possible contingency or to anticipate the final system, crane, or configuration that uses this equipment. For systems using the equipment covered by this manual, the supplier and owner of the system are responsible for the system's compliance with all applicable industry standards, and with all applicable federal, state and local regulations/codes.

This manual includes instructions and parts information for a variety of hoist types. Therefore, all instructions and parts information may not apply to any one type or size of specific hoist. Disregard those portions of the instructions that do not apply.

Record your hoist's Code and Serial Number (see Section 3.11.6 and Figure 10-1) on the front cover of this manual for identification and future reference to avoid referring to the wrong manual for information or instructions on installation, operation, inspection, maintenance, or parts.

Use only Harrington authorized replacement parts in the service and maintenance of this hoist.

WARNING

Equipment described herein is not designed for and **MUST NOT** be used for lifting, supporting, or transporting people, or for lifting or supporting loads over people.

Equipment described herein should not be used in conjunction with other equipment unless necessary and/or required safety devices applicable to the system, crane, or application are installed by the system designer, system manufacturer, crane manufacturer, installer, or user.

Modifications to upgrade, rerate, or otherwise alter this equipment shall be authorized only by the original equipment manufacturer.

Equipment described herein may be used in the design and manufacture of cranes or monorails. Additional equipment or devices may be required for the crane and monorail to comply with applicable crane design and safety standards. The crane designer, crane manufacturer, or user is responsible to furnish these additional items for compliance. Refer to ANSI/ASME B30.17, "Safety Standard for Top-Running Single Girder Cranes"; ANSI/ASME B30.2 "Safety Standard for Top-Running Double-Girder Cranes"; and ANSI/ASME B30.11 "Safety Standard for Underhung Cranes and Monorails".

If a below-the-hook lifting device or sling is used with a hoist, refer to ANSI/ASME B30.9, "Safety Standard for Slings" or ANSI/ASME B30.20, "Safety Standard for Below-the-Hook Lifting Devices".

Hoists, trolleys and cranes, used to handle hot molten material may require additional equipment or devices. Refer to ANSI Z241.2, "Safety Requirements for Melting and Pouring of Metals in the Metalcasting Industry".

Failure to read and comply with any one of the limitations noted herein can result in serious bodily injury or death, and/or property damage.

DANGER

HAZARDOUS AIR PRESSURE IS PRESENT IN THE HOIST, IN THE SUPPLY OF COMPRESSED AIR TO THE HOIST, AND IN THE CONNECTIONS BETWEEN COMPONENTS.

Before performing ANY maintenance on the equipment, de-energize the supply of compressed air to the equipment, and lock and tag the supply device in the de-energized position. Refer to ANSI Z244.1, "Personnel Protection - Lockout/Tagout of Energy Sources."

Only trained and competent personnel should inspect and repair this equipment.

NOTICE

It is the responsibility of the owner/user to install, inspect, test, maintain, and operate a hoist in accordance with ANSI/ASME B30.16, "Safety Standard for Overhead Hoists", OSHA Regulations. If the hoist is installed as part of a total lifting system, such as an overhead crane or monorail, it is also the responsibility of the owner/user to comply with the applicable ANSI/ASME B30 volume that addresses that type of equipment.

It is the responsibility of the owner/user to have all personnel that will install, inspect, test, maintain, and operate a hoist read the contents of this manual and applicable portions of ANSI/ASME B30.16, "Safety Standard for Overhead Hoists" and OSHA Regulations. If the hoist is installed as part of a total lifting system, such as an overhead crane, the applicable ANSI/ASME B30 volume that addresses that type of equipment must also be read by all personnel.

If the hoist owner/user requires additional information, or if any information in the manual is not clear, contact Harrington or the distributor of the hoist. Do not install, inspect, test, maintain, or operate this hoist unless this information is fully understood.

A regular schedule of inspection of the hoist in accordance with the requirements of ANSI/ASME B30.16 should be established and records maintained.

1.2 Warning Tags and Labels

The warning tag illustrated below in Figure 1-1 is supplied with each hoist shipped from the factory. If the tag is not attached to your hoist (for pendant control, the warning tag is attached to the pendant hose; for the pull cord control, the warning tag is attached to the up cord), order a tag from your dealer and install it. See parts list in the parts section of this manual. Read and obey all warnings attached to this hoist. Tag is not shown actual size.

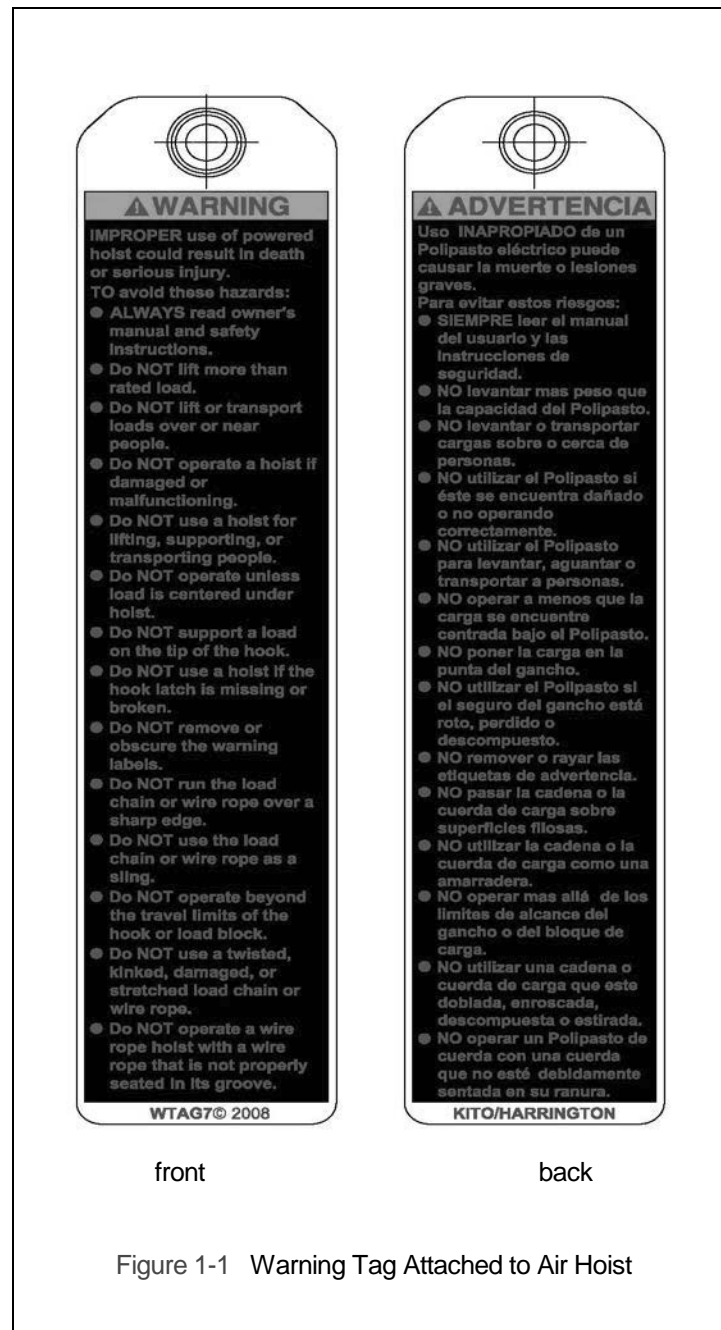
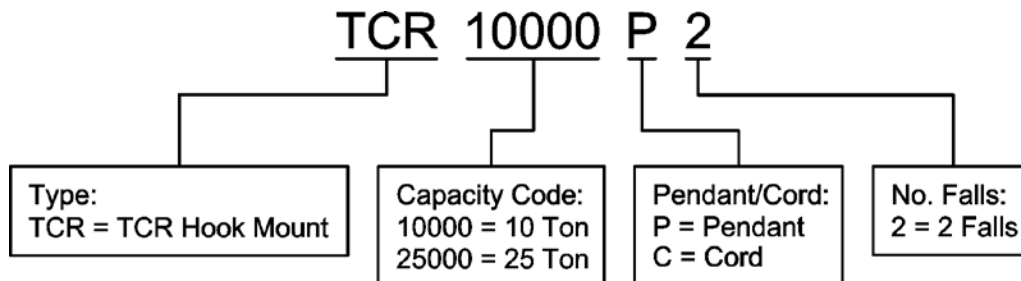

Figure 1-1 Warning Tag Attached to Air Hoist

2.0 Technical Information

2.1 Specifications

2.1.1 Product Code



2.1.2 Operating Conditions and Environment

Temperature range: +14° to +140°F (-10° to +60°C)

Relative Humidity: 85% or less

Supply Air: 60 to 90 pounds per square inch

Air Consumption: 170 to 220 cubic feet minute

Air Lubrication Requirements: Minimum 10 to 15 drops per minute (2-3 cc/min) of oil

Air Filtration Requirements: Maximum 5 micron air filter or finer

Load Limiter: Adjustable; Factory set to 125% of rated capacity

Table 2-1 Hoist Specifications

	Cap. (Tons)	Product Code	Standard Lift (ft)	Push Button Hose L (ft)	Up/Down Speeds (ft/min @ 90 psi)		Up/Down Air Consumption Rates (cubic ft/min @ 90 psi)		Load Chain Diameter (mm) x Chain Fall Lines	Net Weight (lbs)	Weight for Additional One Foot of Lift (lbs)
					No Load	w/Full Load	No Load	w/Full Load			
Pendant Model	10	TCR10000P2	10	8.8	7.2/5.9	5.1/7.6	220/180	180/210	16 x 2	476	3.8
	25	TCR25000P2		9.4	2.1/1.6	1.8/2.2	210/190	170/200	22 x 2	1082	7.0
Cord Model	10	TCR10000C2	10	8.1	7.2/5.9	5.1/7.6	220/180	180/210	16 x 2	465	3.8
	25	TCR25000C2		8.7	2.1/1.6	1.8/2.2	210/190	170/200	22 x 2	1074	7.0

2.2 Dimensions

Table 2-2 TCR with Pendant Control Dimensions										
<div style="display: flex; justify-content: space-around;"> TCR10000P2 TCR25000P2 </div>										
Cap. (Tons)	Product Code	Headroom C (in)	a (in)	b (in)	d (in)	e (in)	g (in)	h (in)	i (in)	j (in)
10	TCR10000P2	35.0	21.7	18.4	9.7	12.0	1.6	7.4	11.0	2.4
25	TCR25000P2	56.7	27.5	18.7	14.3	13.2	3.1	6.4	12.3	4.9

TABLE 2-3 TCR WITH CORD CONTROL DIMENSIONS										
<div style="display: flex; justify-content: space-around;"> TCR10000C2 TCR25000C2 </div>										
Cap. (Tons)	Product Code	Headroom C (in)	a (in)	b (in)	d (in)	e (in)	g (in)	h (in)	i (in)	j (in)
10	TCR10000C2	35.0	21.7	18.4	9.7	12.0	1.6	7.4	11.0	2.4
25	TCR25000C2	56.7	27.5	18.7	14.3	13.2	3.1	6.4	12.3	4.9

Table 2-4 Top and Bottom Hook Dimension*								
Units = inch								
Product Code	a	b	c	d	e	f	g	h
TCR10000C/P2	2.8	2.4	2.4	2.2	2.4	2.6	1.6	7.1
TCR25000C/P2	4.9	3.5	3.9	3.5	4.9	4.9	3.1	13.1

*Refer to Section 5.7 for inspection dimensions and limits.

2.3 Part Names

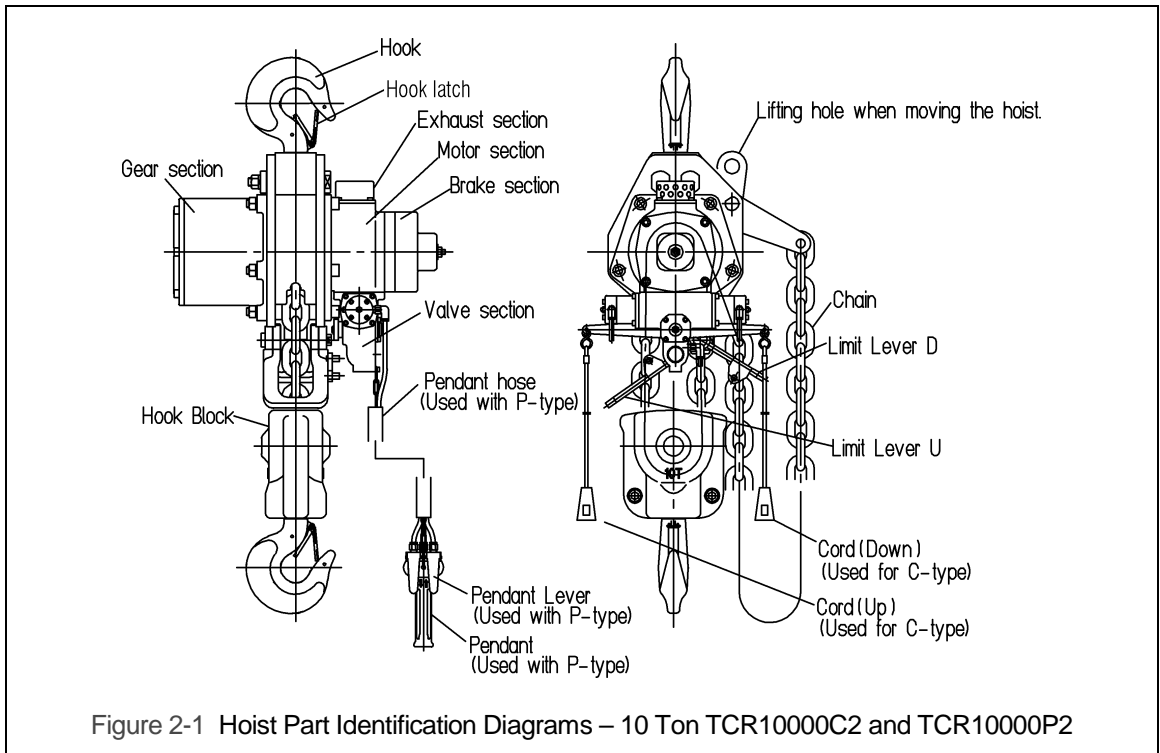

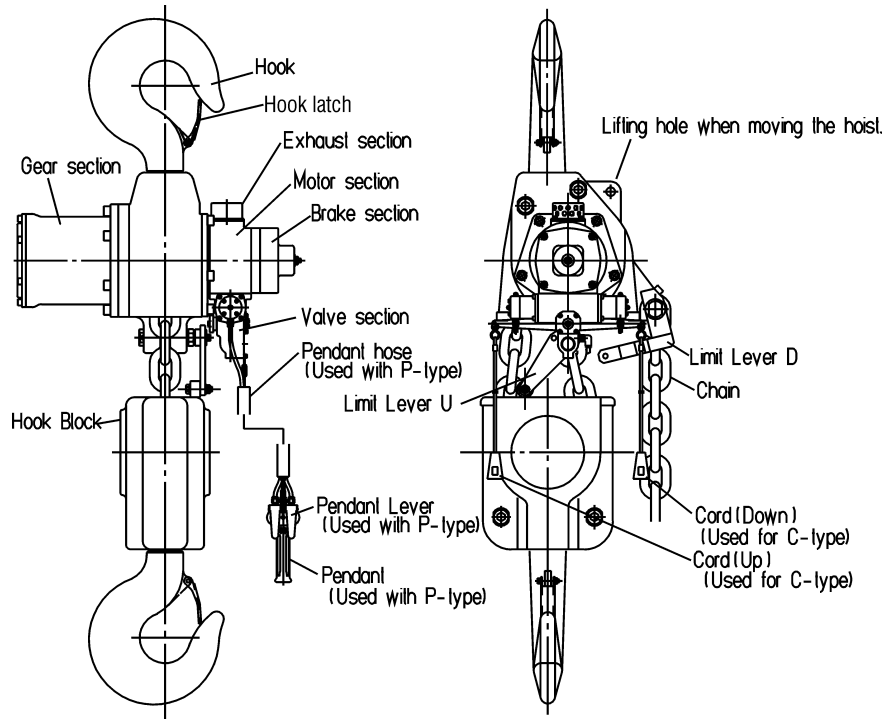

Figure 2-2 Hoist Part Identification Diagrams – 25 Ton TCR25000P2 and TCR25000C2

3.0 Preoperational Procedures

3.1 Air Supply System Requirements

- 3.1.1 **NOTICE** Pressure and Flow - Verify that the air supply system has capacity to supply your air hoist with required pressure and flow. Otherwise the hoist may operate poorly or may fail to operate. See Section 3.2.
- 3.1.2 **CAUTION** Lubrication - The hoist requires lubrication for proper operation. The oil in the air supply is the primary source of lubrication to the hoist. Therefore, a dedicated air supply lubricator must be used with the hoist. Refer to Section 3.3.
- 3.1.3 **CAUTION** Air Quality - Good air quality is essential to prevent damage to your hoist and to ensure its proper operation. The air must be clean and free of debris such as dirt and rust. Refer to Section 3.4 for filtration requirements. The air must also be dry; free of moisture and water. Refer to Section 3.5.

3.2 Air Supply Capacity And Regulation

- 3.2.1 Capacity - The air supply system must be capable of delivering the required airflow (cfm) to the hoist inlet port. Without the required airflow the hoist will not operate properly or may not operate at all. See Section 2.0 for your hoists air consumption requirements. In determining if your system is capable of supplying the required airflow, consider the following:
- Capacity of compressor(s) and tank
 - Other air consuming equipment
 - Flow restrictions such as pipes, hoses, valves and fittings
- Inadequate capacity will cause a significant drop in pressure when the hoist is operated, and could cause poor performance or failure to operate.
- 3.2.2 Regulation - The hoist requires a constant supply of air at a pressure of between 60 and 90 psi. If the air supply is not regulated or is regulated at a pressure greater than 90 psi, then a regulator must be used. The regulator may be located anywhere upline of the lubricator in the air supply to the hoist.

3.3 Lubrication

- 3.3.1 **CAUTION** The hoist must be supplied with its own lubricator. The lubricator must be located as follows:
- 1) **Best location** - At the hoist inlet. In this case the lubricator can be either the mist type or drop type.
 - 2) **Second best location** - No more than 15 feet away from the hoist, at the same elevation or above the hoist inlet. In this case the mist type lubricator must be used.
 - 3) **Third best location** - No more than 15 feet away below the hoist. In this case the mist type lubricator must be used.
- 3.3.2 **CAUTION** The lubricator must be set to deliver the equivalent of 10 to 15 drops of oil per minute (2 to 3 cc/minute). The hoist's exhaust will emit a fine oil mist when properly lubricated.

3.4 Filtration

- 3.4.1 **CAUTION** The air entering the hoist inlet must not contain any particulate greater than 5 microns in size. Therefore, the hoist must have a 5 micron filter in its air supply. The filter must be upstream of the lubricator.

3.4.2 The filter servicing the hoist can also service other hoists and air consuming equipment. In this case, the air filter must be in sized for the total air consumption of the equipment it is servicing.

3.5 Air Dryer - ⚠ CAUTION To prevent corrosion and hoist malfunction, employ an air dryer in the air supply system to ensure that dry air is supplied to the hoist. If there is moisture in the air supplied to the hoist, this moisture will cause corrosion on internal hoist components during periods when the hoist is idle leading to hoist malfunction.

3.6 Piping, Hoses And Fittings

3.6.1 **⚠ CAUTION** System Configuration - The system should be configured as shown in Figure 3-1. Since moisture tends to accumulate in compressed air systems, corrosion may result if the system is not periodically drained.

- Arrange for a drain in the air supply piping at the lowest point in the piping, and
- Periodically drain the system to remove moisture/water from the system and to prevent corrosion.
- Filter, regulator (if equipped), and lubricator must be arranged in the order shown in Figure 3-2.

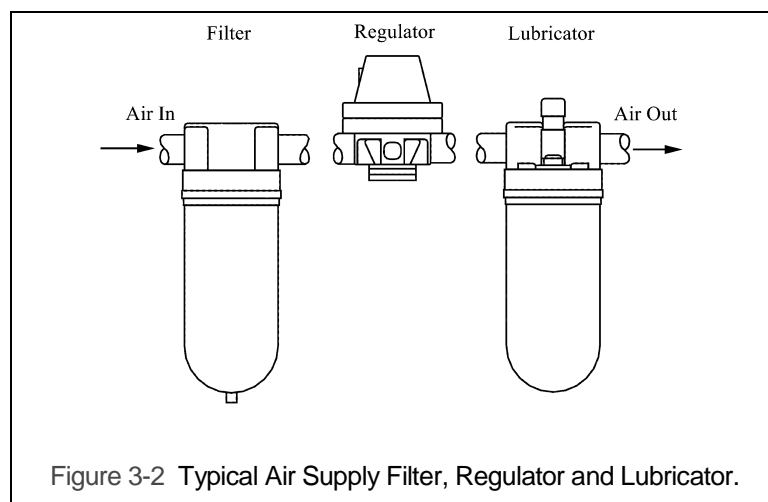
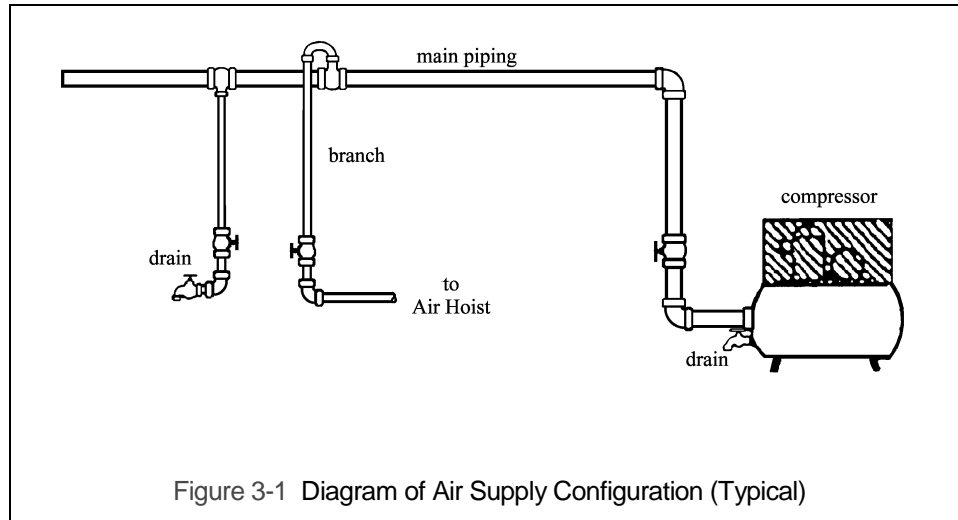

3.6.2 **NOTICE** Piping - Pipe should be sized to accommodate the hoist airflow requirements. Table 3-1 gives recommended pipe sizes.

Table 3-1 Air Supply Pipe and Hose Sizes		
Model	Diameter of Supply Pipe	Diameter of Supply Hose
TCR10000P2 TCR25000C2 TCR10000P2 TCR25000C2	Inside diameter 1.25 inch or larger	Inside diameter 1.0 inch or larger

3.6.3 **NOTICE** Hoses - The connection from the air supply system piping to the hoist must be made with a flexible pressure hose. Due to normal line losses in air supply lines:

- Do not use hose smaller than specified in Table 3-1, and
- Limit the length of the hose to that specified in Figure 3-3.

If your application exceeds these requirements consult factory.

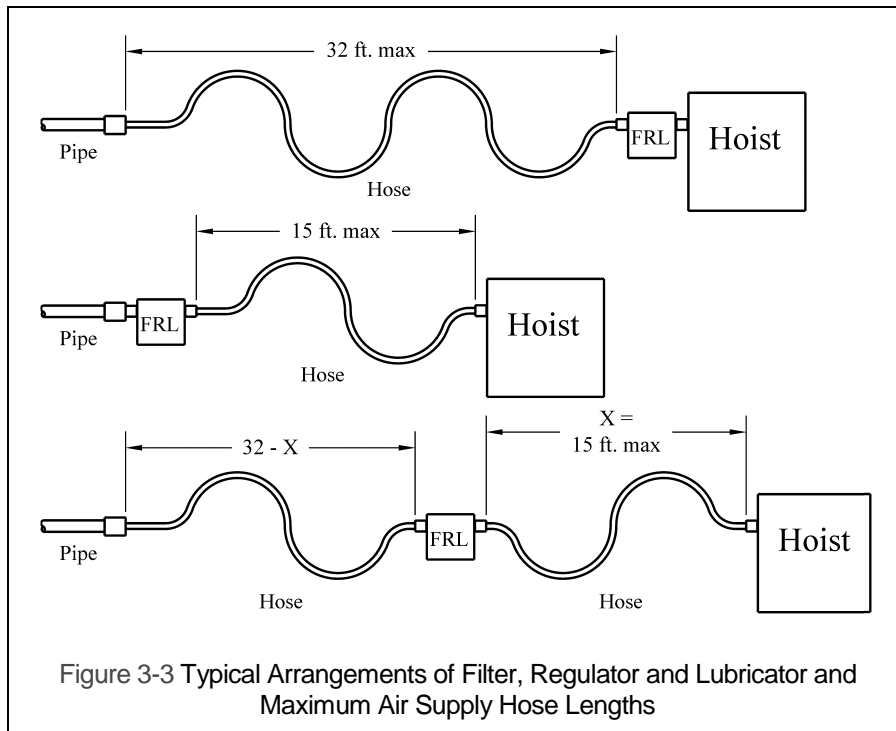

3.6.4 **CAUTION** Fittings - Important considerations regarding fittings in the hoist's air supply include:

- When connecting air supply components, remove all dirt or debris from the connecting surfaces of the hoses, pipes, fittings, or threaded fasteners to prevent contaminants from entering the hoist.
- Keep airflow restrictions such as quick disconnect fittings, bends, elbows, and adapters to a minimum.

- 3.6.5 **⚠ CAUTION** Before connecting the hoist to its air supply line; perform the proper draining and purging procedures to prevent contaminants or moisture from entering the hoist.

3.7 Mounting Location

- 3.7.1 **⚠ WARNING** Prior to mounting the hoist ensure that the suspension and its supporting structure are adequate to support the hoist and its loads. If necessary consult a professional that is qualified to evaluate the adequacy of the suspension location and its supporting structure.

- 3.7.2 **NOTICE** See Section 7.6 for outdoor installation considerations.

3.8 Connecting Hoist to Air Supply

- 3.8.1 **⚠ WARNING** HAZARDOUS AIR PRESSURE IS PRESENT IN THE HOIST, IN THE SUPPLY OF COMPRESSED AIR TO THE HOIST, AND IN THE CONNECTIONS BETWEEN COMPONENTS.

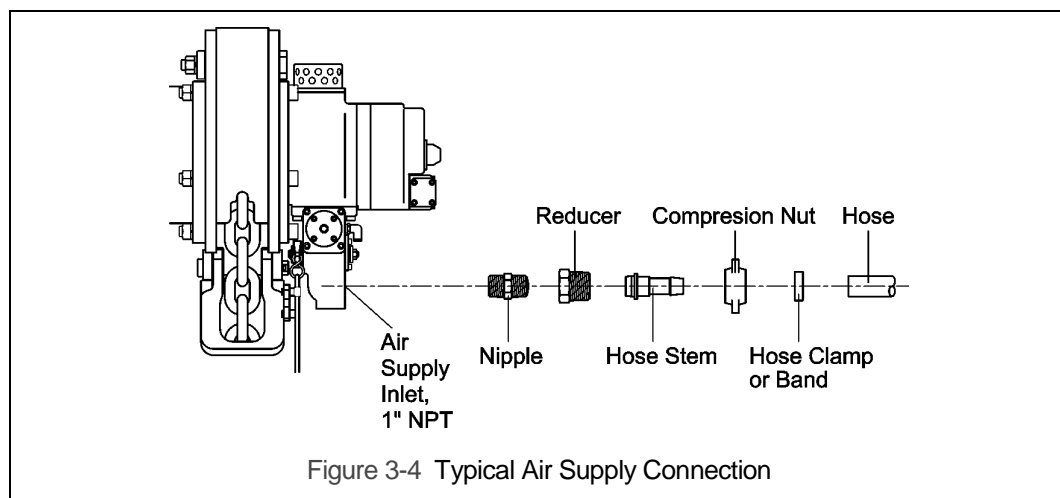

- 3.8.2 Shut off the air supply and stop the airflow completely. Lock out and tag out in accordance with ANSI Z244.1 "Personnel Protection -Lockout/Tagout of Energy Sources".

- 3.8.3 **⚠ CAUTION** Before connecting the air supply hose to the hoist, always purge the air hose to clear any debris and water.

- 3.8.4 Apply approximately 10-15 drops of turbine oil (see approved lubricant under Section 6.0 Lubricants) into the hose before attaching to the hoist.

- 3.8.5 Make connections to air supply; reference Figure 3-4. Use a reducing adapter at the hoist valve section for hose sizes larger than 1 inch.

- 3.8.6 **NOTICE** Where conditions dictate, the installation sequence can be reversed by mounting the hoist first (Section 3.9) followed by connecting the air supply (Section 3.8).

3.9 Mounting the Hoist

- 3.9.1 Manual Trolley - Follow instructions in Owner's Manual provided with the trolley.

- 3.9.2 Motorized Trolley - Follow instructions in Owner's Manual provided with the trolley.

- 3.9.3 Hook Mounted to a Fixed Location - Attach the hoist's top hook to the fixed suspension point.

- 3.9.4 **⚠ WARNING** Ensure that the fixed suspension point rests on the center of the hook's saddle and that the hook's latch is engaged .

3.10 Non-Stationary Application

- 3.10.1 For applications such as rental fleets or construction sites where the hoist is moved from place-to-place, a filter and lubricator are still required. Consult factory for recommended methods.
- 3.10.2 Connections and fittings must be kept clean and care taken to prevent dirt, debris and moisture from entering the hoist.
- 3.10.3 Recommended practice for removing the hoist from an installation:
 - Run the hoist briefly with well lubricated air
 - Disconnect the air supply line
 - Inject a small quantity (approximately 20 drops) of oil into the hoist's inlet port
 - Plug the inlet port

3.11 Preoperational Checks and Trial Operation

- 3.11.1 **CAUTION** Check for the availability of required operating air pressure of between 60 PSI to 90 PSI at the hoist's inlet port before trying to operate the hoist.
- 3.11.2 **WARNING** Verify that the load chain is not twisted or tangled and that the bottom hook is not capsized prior to operating the hoist. Correct all chain irregularities before conducting the first hoist operation. See Figures 3-5 and 3-6.

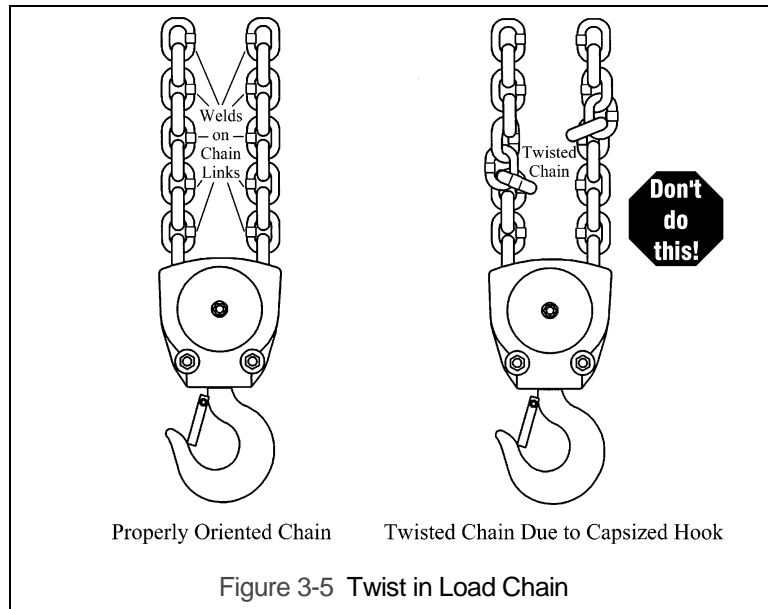

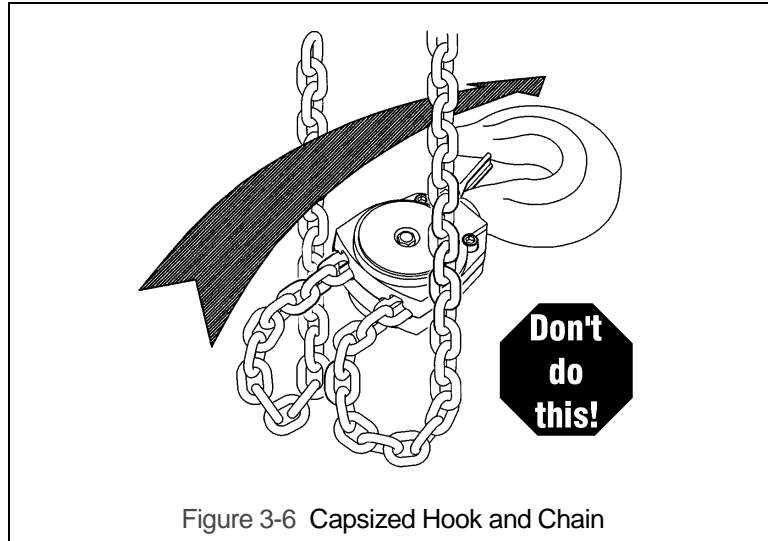

3.11.3 **⚠ WARNING** Confirm the adequacy of the rated capacity for all slings, chains, wire ropes and all other lifting attachments before use. Inspect all load suspension members for damage prior to use and replace or repair all damaged parts.

3.11.4 **⚠ WARNING** Verify that the Chain/Limit Levers are operational and can move freely in both the up and down directions. For reference see Figure 3-7.

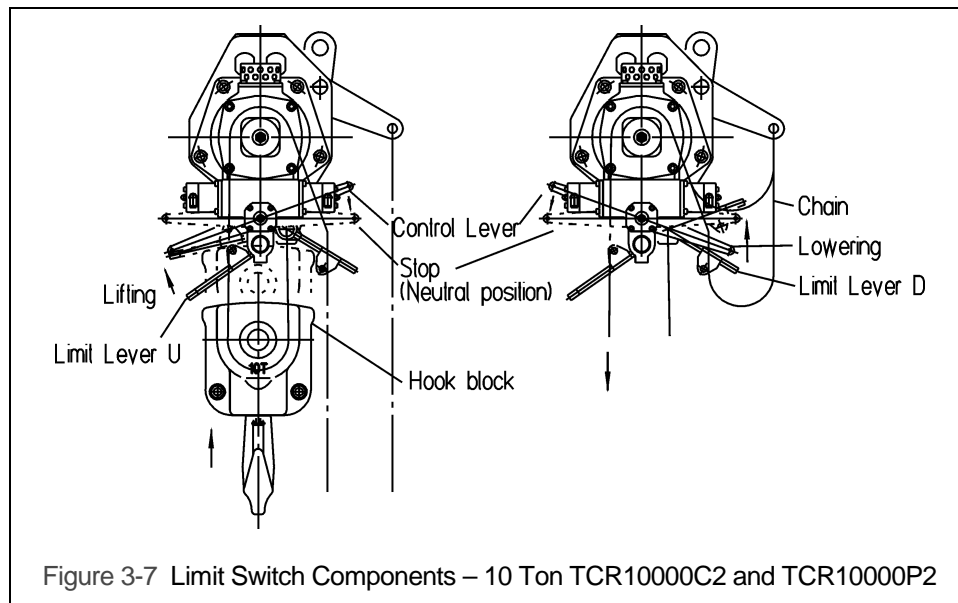

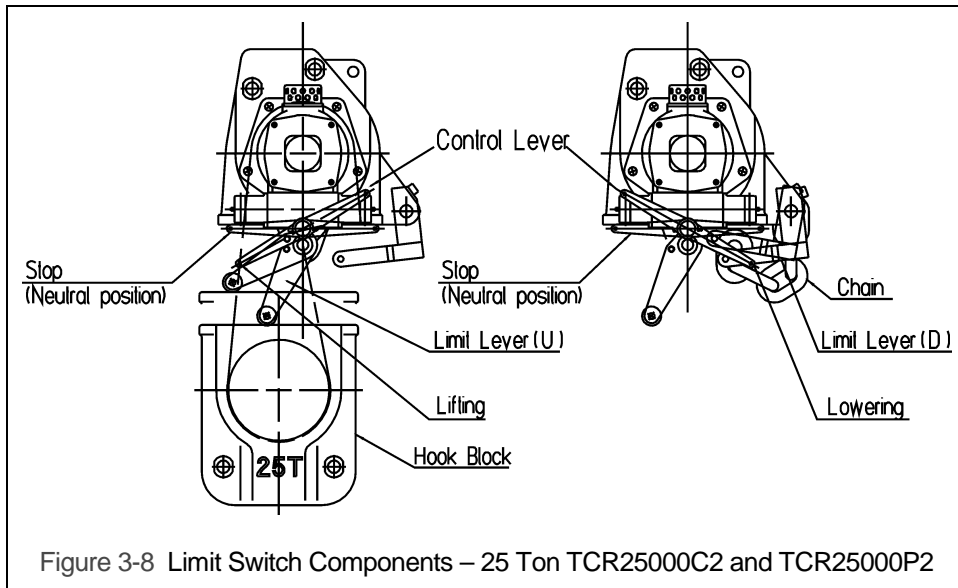

- 3.11.5 Measure and record the “K” dimension of all hooks on hoist. See Table 5-6 under Section 5, “Inspection”. Always use the same side of the hook to measure and record the “K” dimension.
- 3.11.6 Record the hoist Code Number and Serial Number (from the nameplate on the hoist – see Section 10) in the space provided on the cover of this manual.
- 3.11.7 Ensure that the hoist is properly installed to either a fixed point, or trolley, whichever applies.
- 3.11.8 If hoist is installed on a trolley, ensure that
- trolley is properly installed on the beam, and
 - stops for the trolley are correctly positioned and securely installed on the beam.
- 3.11.9 Ensure that all nuts, bolts and split (cotter) pins are sufficiently fastened.
- 3.11.10 For hoists with pendant controls, Ensure that the Pendant Hoses and Strain Relief Chain are properly attached to the hoist. See Section 7.4.
- 3.11.11 **⚠ CAUTION** Check Air Supply - Check air supply before everyday use. Ensure proper air quality and air pressure.
- 3.11.12 **⚠ CAUTION** Check the lubricator for proper function and adequate oil level.
- 3.11.13 Confirm proper operation.
- Before operating read and become familiar with Section 4 - Operation.
 - Before operating ensure that the hoist (and trolley) meets the Inspection, Testing and Maintenance requirements of ANSI/ASME B30.16.
 - Before operating ensure that nothing will interfere with the full range of the hoist’s (and trolley’s) operation.
- 3.11.14 Proceed with trial operation to confirm proper operation.
- Initially operate slowly under no load in both directions. Verify controls agree with hoist direction.
 - Perform inspections per Section 5.3, “Frequent Inspections”.

4.0 Operation

4.1 Introduction

DANGER

DO **NOT** WALK UNDER A SUSPENDED LOAD

WARNING

HOIST OPERATORS SHALL BE REQUIRED TO READ THE OPERATION SECTION OF THIS MANUAL, THE WARNINGS CONTAINED IN THIS MANUAL, INSTRUCTION AND WARNING LABELS ON THE HOIST OR LIFTING SYSTEM, AND THE OPERATION SECTIONS OF ANSI/ASME B30.16 and ANSI/ASME B30.10. THE OPERATOR SHALL ALSO BE REQUIRED TO BE FAMILIAR WITH THE HOIST AND HOIST CONTROLS BEFORE BEING AUTHORIZED TO OPERATE THE HOIST OR LIFTING SYSTEM.

HOIST OPERATORS SHOULD BE TRAINED IN PROPER RIGGING PROCEDURES FOR THE ATTACHMENT OF LOADS TO THE HOIST HOOK.

HOIST OPERATORS SHOULD BE TRAINED TO BE AWARE OF POTENTIAL MALFUNCTIONS OF THE EQUIPMENT THAT REQUIRE ADJUSTMENT OR REPAIR, AND TO BE INSTRUCTED TO STOP OPERATION IF SUCH MALFUNCTIONS OCCUR, AND TO IMMEDIATELY ADVISE THEIR SUPERVISOR SO CORRECTIVE ACTION CAN BE TAKEN.

HOIST OPERATORS SHOULD HAVE NORMAL DEPTH PERCEPTION, FIELD OF VISION, REACTION TIME, MANUAL DEXTERITY, AND COORDINATION.

HOIST OPERATORS SHOULD **NOT** HAVE A HISTORY OF OR BE PRONE TO SEIZURES, LOSS OF PHYSICAL CONTROL, PHYSICAL DEFECTS, OR EMOTIONAL INSTABILITY THAT COULD RESULT IN ACTIONS OF THE OPERATOR BEING A HAZARD TO THE OPERATOR OR TO OTHERS.

HOIST OPERATORS SHOULD **NOT** OPERATE A HOIST OR LIFTING SYSTEM WHEN UNDER THE INFLUENCE OF ALCOHOL, DRUGS, OR MEDICATION.

OVERHEAD HOISTS ARE INTENDED ONLY FOR VERTICAL LIFTING SERVICE OF FREELY SUSPENDED UNGUIDED LOADS. DO **NOT** USE HOIST FOR LOADS THAT ARE NOT LIFTED VERTICALLY, LOADS THAT ARE NOT FREELY SUSPENDED, OR LOADS THAT ARE GUIDED.

NOTICE

- Read ANSI/ASME B30.16 and ANSI/ASME B30.10.
- Read the hoist manufacturer's Operating and Maintenance Instructions.
- Read all labels attached to equipment.

The operation of an overhead hoist involves more than activating the hoist's controls. Per the ANSI/ASME B30 standards, the use of an overhead hoist is subject to certain hazards that cannot be mitigated by engineered features, but only by the exercise of intelligence, care, common sense, and experience in anticipating the effects and results of activating the hoist's controls. Use this guidance in conjunction with other warnings, cautions, and notices in this manual to govern the operation and use of your overhead hoist.

4.2 Shall's and Shall Not's for Operation

WARNING

Improper operation of a hoist can create a potentially hazardous situation which, if not avoided, could result in death or serious injury, and substantial property damage. To avoid such a potentially hazardous situation **THE OPERATOR SHALL:**

- **NOT** lift more than rated load for the hoist.
- **NOT** operate unless load is centered under hoist.
- **NOT** use damaged hoist or hoist that is not working properly.
- **NOT** use hoist with twisted, kinked, damaged, or worn chain.
- **NOT** use hoist if the bottom hook is capsized (double fall hoists - see **Section 3.11**).
- **NOT** use the hoist to lift, support, or transport people.
- **NOT** lift loads over people.
- **NOT** apply load unless load chain is properly seated in the load sheave (and idle sheave for hoist with two chain falls).
- **NOT** use the hoist in such a way that could result in shock or impact loads being applied to the hoist.
- **NOT** attempt to lengthen the load chain or repair damaged load chain.
- **NOT** operate hoist when it is restricted from forming a straight line from hook to hook in the direction of loading.
- **NOT** use load chain as a sling or wrap load chain around load.
- **NOT** apply the load to the tip of the hook or to the hook latch.
- **NOT** apply load if binding prevents equal loading on all load supporting chains.
- **NOT** operate beyond the limits of the load chain travel.
- **NOT** operate hoist with missing/damaged chain springs, shock absorbers, stoppers, striker plates or limit locks.
- **NOT** leave load supported by the hoist unattended unless specific precautions have been taken.
- **NOT** allow the chain, or hook to be used as an electrical or welding ground.
- **NOT** allow the chain, or hook to be touched by a live welding electrode.
- **NOT** remove or obscure the warnings on the hoist.
- Be familiar with operating controls, procedures, and warnings.
- Make sure the unit is securely attached to a suitable support before applying load.
- Make sure load slings or other approved single attachments are properly sized, rigged, and seated in the hook saddle.
- Take up slack carefully - make sure load is balanced and load-holding action is secure before continuing.
- Make sure all persons stay clear of the supported load.
- Protect the hoist's load chain from weld splatter or other damaging contaminants.
- Report malfunctions or unusual performances (including unusual noises) of the hoist and remove the hoist from service until the malfunction or unusual performance is resolved.
- Make sure hoist limit switches function properly.
- Warn personnel before lifting or moving a load.
- Warn personnel of an approaching load.

⚠ CAUTION

Improper operation of a hoist can create a potentially hazardous situation which, if not avoided, could result in minor or moderate injury, or property damage. To avoid such a potentially hazardous situation **THE OPERATOR SHALL:**

- Maintain a firm footing or be otherwise secured when operating the hoist.
- Check brake function by tensioning the hoist prior to each lift operation.
- Use hook latches. Latches are to retain slings, chains, etc. under slack conditions only.
- Make sure the hook latches are closed and not supporting any parts of the load.
- Make sure the load is free to move and will clear all obstructions.
- Avoid swinging the load or hook.
- Make sure hook travel is in the same direction as shown on controls.
- Inspect the hoist regularly, replace damaged or worn parts, and keep appropriate records of maintenance.
- Use the hoist manufacturer's recommended parts when repairing the unit.
- Lubricate load chain per hoist manufacturer's recommendations.
- **NOT** use the hoist load limiting or warning device to measure load.
- **NOT** use limit switches as routine operating stops. They are emergency devices only.
- **NOT** allow your attention to be diverted from operating the hoist.
- **NOT** allow the hoist to be subjected to sharp contact with other hoists, structures, or objects through misuse.
- **NOT** adjust or repair the hoist unless qualified to perform such adjustments or repairs.

4.3 Hoist Controls

- 4.3.1 For hoists mounted to motorized trolleys follow the control instruction included in the trolley 's Owner's Manual.
- 4.3.2 Pendant Control - When using the pendant control depress the up lever to raise the hoist or the down lever to lower the hoist as shown in Figure 4-1 below. To stop motion release the lever switches.

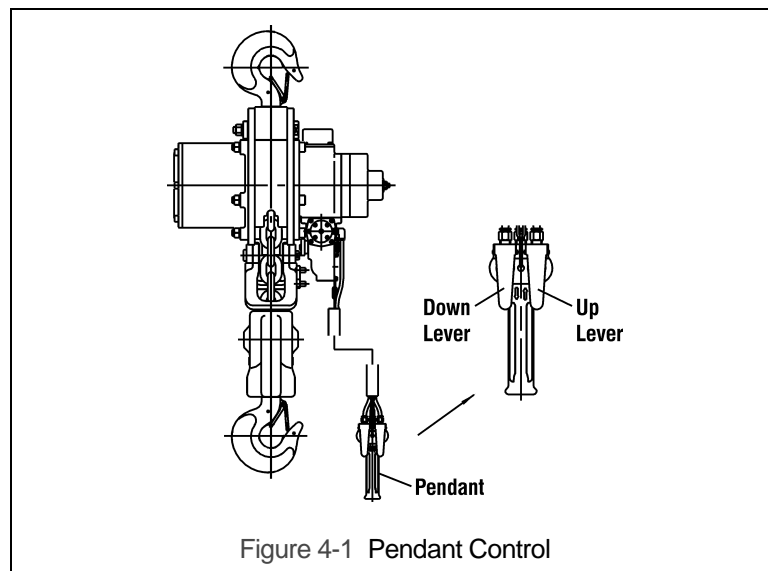
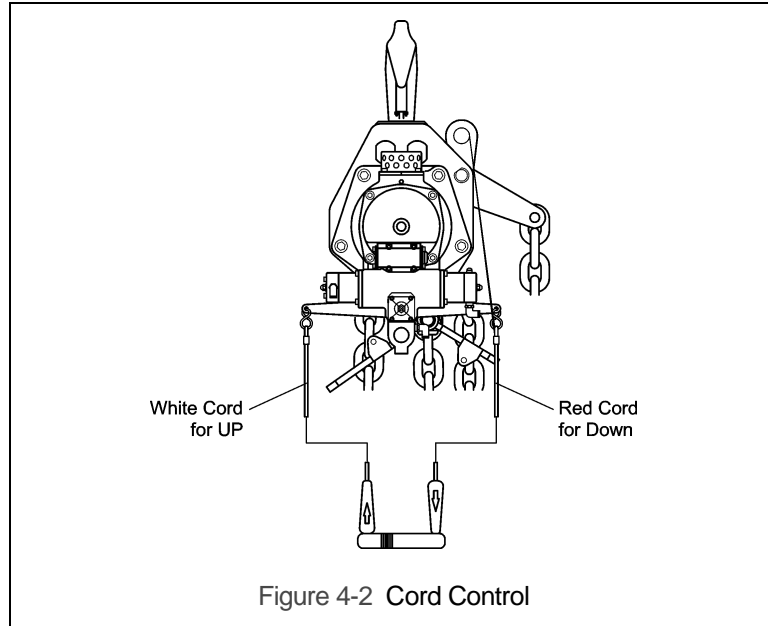

Figure 4-1 Pendant Control

- 4.3.3 Cord Control - When using a hoist with cord control, pull down on the appropriate colored cord to raise or lower the hoist. White indicates the raise control and red indicates lowering control. Release the cords to stop the hoist. Refer to Figure 4-2 below.



- 4.3.4 **CAUTION** Make sure the motor completely stops before reversing direction.

4.4 Adjusting the Controls

- 4.4.1 For pendant control, the speed can be adjusted by the amount the lever is depressed. As shown below in Figure 4-3, by depressing the lever slightly, you will be able control the hoist's motions slowly and with more precision. By depressing the lever further, the speed of the hoist will be increased until the lever is fully depressed.

- 4.4.2 For the cord type control, adjust the speed by varying the amount of pull on the cord. Refer to Figure 4-4.

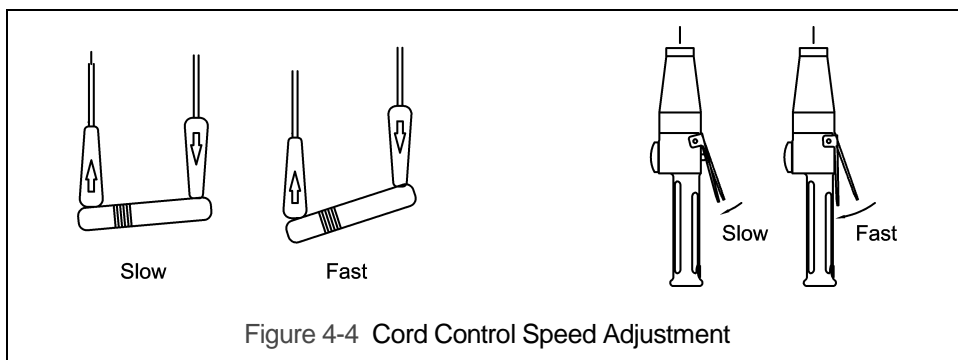

4.5 Operation of the Load Limiter

- 4.5.1 If a hoist is used to lift a load that exceeds the hoist's rated capacity, the load limiter will cause the hoist to automatically stop lifting.
- 4.5.2 If the hoist stops lifting automatically, lower and remove the load from the hoist.
- 4.5.3 If the load is at or below the hoist's capacity rating and the hoist stops lifting automatically, the load limiter may need adjustment.
 - Check air line pressure to ensure adequate pressure at the hoist.
 - If pressure is adequate, adjust the load limiter. For load limiter adjustment, refer to [Section 7](#).

5.0 Inspection

5.1 General

- 5.1.1 The inspection procedure herein is based on ANSI/ASME B30.16. The following definitions are from ANSI/ASME B30.16 and pertain to the inspection procedure below.
- **Designated Person** - a person selected or assigned as being competent to perform the specific duties to which he/she is assigned.
 - **Qualified Person** - a person who, by possession of a recognized degree or certificate of professional standing, or who, by extensive knowledge, training, and experience, has successfully demonstrated the ability to solve or resolve problems relating to the subject matter and work.
 - **Normal Service** - that distributed service which involves operation with randomly distributed loads within the rated load limit, or uniform loads less than 65% of rated load for not more than 25% of the time.
 - **Heavy Service** - that service which involves operation within the rated load limit which exceeds normal service.
 - **Severe Service** - that service which involves normal or heavy service with abnormal operating conditions.

5.2 Inspection Classification

- 5.2.1 Initial Inspection - prior to initial use, all new, altered, or modified hoists shall be inspected by a designated person to ensure compliance with the applicable provisions of this manual.
- 5.2.2 Inspection Classification - the inspection procedure for hoists in regular service is divided into two general classifications based upon the intervals at which inspection should be performed. The intervals in turn are dependent upon the nature of the critical components of the hoist and the degree of their exposure to wear, deterioration, or malfunction. The two general classifications are herein designated as FREQUENT and PERIODIC, with respective intervals between inspections as defined below.
- 5.2.3 FREQUENT Inspection - visual examinations by the operator or other designated personnel with intervals per the following criteria:
- Normal service - monthly
 - Heavy service - weekly to monthly
 - Severe service - daily to weekly
 - Special or infrequent service - as recommended by a qualified person before and after each occurrence.
- 5.2.4 PERIODIC Inspection - visual inspection by a designated person with intervals per the following criteria:
- Normal service - yearly
 - Heavy service - semiannually
 - Severe service - quarterly
 - Special or infrequent service - as recommended by a qualified person before the first such occurrence and as directed by the qualified person for any subsequent occurrences.

5.3 Frequent Inspection

- 5.3.1 Inspections should be made on a FREQUENT basis in accordance with Table 5-1, "Frequent Inspection." Included in these FREQUENT Inspections are observations made during operation for any defects or damage that might appear between Periodic Inspections. Evaluation and resolution of the results of FREQUENT Inspections shall be made by a designated person such that the hoist is maintained in safe working condition.

Table 5-1 Frequent Inspection
All functional operating mechanisms for maladjustment and unusual sounds.
Operation of limit switch and associated components
Hoist braking system for proper operation
Hooks in accordance with ANSI/ASME B30.10
Hook latch operation
Load chain in accordance with Section 5.7
Load chain reeving for compliance with Section 3.11 and 7.3
Air valves and components for leakage or damage

5.4 Periodic Inspection

- 5.4.1 Inspections should be made on a PERIODIC basis in accordance with Table 5-2, "Periodic Inspection." Evaluation and resolution of the results of PERIODIC Inspections shall be made by a designated person such that the hoist is maintained in safe working condition.
- 5.4.2 For inspections where load suspension parts of the hoist are disassembled, a load test per ANSI/ASME B30.16 must be performed on the hoist after it is re-assembled and prior to its return to service.

Table 5-2 Periodic Inspection
Requirements of frequent inspection.
Evidence of loose bolts, nuts, or rivets.
Evidence of worn, corroded, cracked, or distorted parts such as load blocks, suspension housing, chain attachments, clevises, yokes, suspension bolts, shafts, gears, bearings and pins.
Evidence of damage to hook retaining nuts or collars and pins, and welds or rivets used to secure the retaining members.
Evidence of damage or excessive wear of load and idler sheaves.
Evidence of excessive wear on motor vanes or on load brake.
Evidence of damage of supporting structure or trolley, if used.
Function labels on pendant control stations for legibility.
Warning label properly attached to the hoist and legible (see Section 1.2).
End connections of load chain.

5.5 Occasionally Used Hoists

5.5.1 Hoists that are used infrequently shall be inspected as follows prior to placing in service:

- Hoist Idle More Than 1 Month, Less Than 1 Year: Inspect per FREQUENT Inspection criteria of Section 5.3 above.
- Hoist Idle More Than 1 Year: Inspect per PERIODIC Inspection criteria of Section 5.4 above.

5.6 Inspection Records

5.6.1 Dated inspection reports and records should be maintained at time intervals corresponding to those that apply for the hoist's PERIODIC interval per Section 5.2.4. These records should be stored where they are available to personnel involved with the inspection, maintenance, or operation of the hoist.

5.6.2 A long range chain inspection program should be established and should include records of examination of chains removed from service so a relationship can be established between visual observation and actual condition of the chain.

5.7 Inspection Methods and Criteria

5.7.1 This section covers the inspection of specific items. The list of items in this section is based on those listed in ANSI/ASME B30.16 for the Frequent and Periodic Inspection. In accordance with ANSI/ASME B30.16, these inspections are not intended to involve disassembly of the hoist. Rather, disassembly for further inspection would be required if frequent or periodic inspection results so indicate. Such disassembly and further inspection should only be performed by a qualified person trained in the disassembly and re-assembly of the hoist.

Table 5-3 Hoist Inspection Methods and Criteria

Item	Method	Criteria	Action
Functional operating mechanisms.	Visual, Auditory	Mechanisms should be properly adjusted and should not produce unusual sounds when operated.	Repair or replace as required.
Limit Switch	Function	Proper operation. Actuation of limit switch should stop hoist.	Repair or replace as required.
Chain Lever/Limit Lever Assembly	Visual, Function	Lever should not be bent or significantly worn and should be able to move freely.	Replace.
Braking System	Function	Braking distance should not exceed approximately five chain links.	Repair or replace as required.
Hooks - Surface Condition	Visual	Should be free of significant rust, weld splatter, deep nicks, or gouges.	Replace.
Hooks - Fretting wear	Measure	The "u" dimension should not be less than minimum value listed in Table 5-6.	Replace.
Hooks - Stretch	Measure	The "K" dimension should not exceed the maximum value for replacement from Table 5-6 (See Section 3.11).	Replace.

Table 5-3 Hoist Inspection Methods and Criteria (continued)			
Item	Method	Criteria	Action
Hooks - Bent Shank or Neck	Visual	Shank and neck portions of hook should be free of deformations	Replace.
Hooks - Yoke Assembly	Visual	Should be free of significant rust, weld splatter, nicks, gouges. Holes should not be elongated, fasteners should not be loose, and there should be no gap between mating parts.	Clean/Lubricate, or replace as required.
Hooks - Swivel Bearing	Visual, Function	Bearing parts and surfaces should not show significant wear, and should be free of dirt, grime and deformations. Hook should rotate freely with no roughness.	Clean/lubricate, or replace as required.
Hooks - Idle Sheave and Axle (Bottom Hook on Double Fall Hoist)	Visual, Function	Pockets of Idle Sheave should be free of significant wear. Idle Sheave surfaces should be free of nicks, gouges, dirt and grime. Bearing parts and surfaces of Idle Sheave and Axle should not show significant wear. Idle Sheave should rotate freely with no roughness or significant free play.	Clean/lubricate, or replace as required.
Hooks - Hook Latches	Visual, Function	Latch should not be deformed. Attachment of latch to hook should not be loose. Latch spring should not be missing and should not be weak. Latch movement should not be stiff - when depressed and released latch should snap smartly to its closed position.	Replace.
Load Chain - Surface Condition	Visual	Should be free of rust, nicks, gouges, dents, and weld splatter. Links should not be deformed, and should not show signs of abrasion. Surfaces where links bear on one another should be free of significant wear.	Replace.
Load Chain - Pitch	Measure	The "L" dimension should not be greater than maximum value listed in Table 5-7.	Replace, inspect Load Sheave (and Idle Sheave for double fall hoist).
Load Chain - Lubrication	Visual, Auditory	Entire surface of each chain link should be coated with lubricant and should be free of dirt and grime. Chain should not emit cracking noise when hoisting a load.	Clean/lubricate (see Sections 6.0).
Load Chain - Reeving	Visual	Chain should be reeved properly through Load Sheave (and Idle Sheave for double fall hoist) - refer to Section 3.11. Chain, limit locks and stoppers should be installed properly - refer to Section 7.3.2.	Reeve/Install chain properly.
Bolts, Nuts and Rivets	Visual, Check with Proper Tool	Bolts, nuts and rivets should not be loose.	Tighten or replace as required.

Table 5-3 Hoist Inspection Methods and Criteria (continued)

Item	Method	Criteria	Action
Housing and Mechanical Components	Visual, Auditory, Vibration, Function	Hoist components including load blocks, suspension housing, chain attachments, clevises, yokes, suspension bolts, shafts, gears, bearings, pins and rollers should be free of cracks, distortion, significant wear and corrosion. Evidence of same can be detected visually or via detection of unusual sounds or vibration during operation.	Replace
Chain Separator	Visual, Measure	The Chain Guide/Side Plate should be free of cracks, distortion, significant wear and corrosion. The "L" and "W" dimension should not be greater than maximum value listed in Table 5-5.	Replace
Motor Brake	Measure, Visual	Motor brake dimension should be within the allowable limits of Table 5-4. See Section 7.2 for gaining access to motor brake. Braking surfaces should be clean, free of grease/oil and should not be glazed.	Replace
Load Sheave	Visual	Pockets of Load Sheave should be free of significant wear. See Section 7.5 to gain visual access to the load sheave.	Replace.
Pendant Control Levers	Visual, Function	Depressing and releasing pendant control levers should cause hoist to operate.	Repair or replace as necessary.
Pendant - Housing	Visual	Pendant housing should be free of cracks and mating surfaces of parts should seal without gaps.	Replace.
Pendant - Tubing	Visual, auditory	Tubing to pendant control switches should not be loose or be leaking air.	Repair or replace as necessary.
Pendant - Labels	Visual	Labels denoting functions should be legible.	Replace.
Warning Labels	Visual	Warning Labels should be affixed to the hoist (see Section 1.2) and they should be legible.	Replace
Hoist Capacity Label	Visual	The label that indicates the capacity of the hoist should be legible and securely attached to the hoist.	Replace.

Table 5-4 Brake Disc Dimension

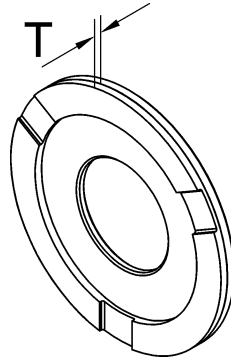

Hoists	Parts View Figure No.	Std Dimension Inch (mm)	Minimum Value for Replacement Inch (mm)
TCR10000C2 TCR10000P2 TCR25000C2 TCR25000P2		T = 0.16 (4.0)	T = 0.10 (2.5)

Table 5-5 Chain Guide/Side Plate Dimensions

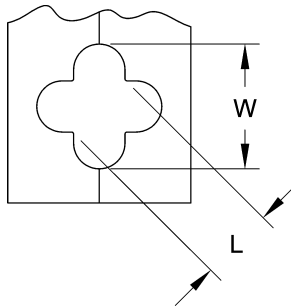

Hoists	Parts View Figure No.	Std Dimension Inch (mm)	Maximum Value for Replacement Inch (mm)
TCR10000C2 TCR10000P2	146	L = 1.57 (40) W = 2.36 (60)	L = 1.69 (42.8) W = 2.48 (63)
TCR25000C2 TCR25000P2	161 & 162	L = 2.20 (55.8) W = 3.82 (97)	L = 2.36 (60) W = 4.02 (102)

Table 5-6 Top Hook & Bottom Hook Dimensions

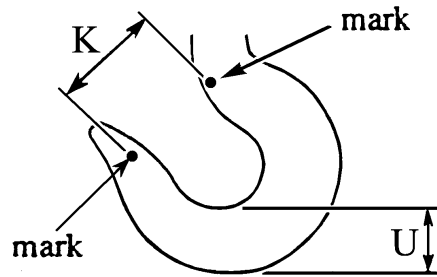

Dimensions K and U should be measured and recorded below prior to any use when the hook is first placed into service.

Hoists	Parts View Figure No.	Recorded Dimension When New	Maximum/Minimum Value for Replacement
TCR10000C2 TCR10000P2	165	Top Hook K = _____ Top Hook U = _____ Bottom Hook K = _____ Bottom Hook U = _____	For K if the measured dimension exceeds 1.05 times the recorded new dimension, the hook should be replaced. For U if the measured dimension is less than .9 times the recorded new dimension, the hook should be replaced.
TCR25000C2 TCR25000P2	180	Top Hook K = _____ Top Hook U = _____ Bottom Hook K = _____ Bottom Hook U = _____	

Table 5-7 Chain Dimensions

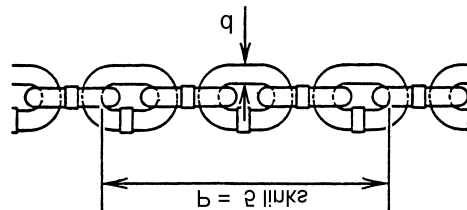

Product Code	Parts View Figure No.	"P" Dimension inch (mm)		"d" Dimension inch (mm)	
		Standard	Discard	Standard	Discard
TCR10000C2 TCR10000P2	182	8.86 (225)	9.00 (228.5)	0.63 (16)	0.61 (15.5)
TCR25000C2 TCR25000P2	179	12.99 (330)	13.14 (333.8)	0.87 (22)	0.85 (21.5)

6.0 Lubrication

6.1 Air Hoist Lubrication

6.1.1 See Section 3.0 for lubrication requirements.

6.1.2 **⚠ CAUTION** Lubrication to the motor will be provided primarily by the air supply lubricator. The recommended amount is 10-15 drops/minute (2-3cc/min.). Refer to Table 6-1 below for the approved lubricant for use with your air hoist.

6.1.3 Additional lubrication to the reduction gears is not necessary. When disassembling the hoist for service or repair, apply new grease to the gears before reassembling the hoist.

6.2 Load Chain Lubrication

6.2.1 For longer life, lightly coat the load chain with machine or gear oil. Ensure that the oil is applied to the bearing surfaces of the load chain links.

6.2.2 The load chain lubrication should be accomplished after cleaning the load chain with acid free cleaning solution. Use approved lubricant in Table 6-1 or equivalent.

6.2.3 For dusty environments, it is acceptable to substitute a dry lubricant.

6.3 Hooks and Suspension Components

6.3.1 Hooks - Bearings should be cleaned and lubricated at least once per year for normal usage. Clean and lubricate more frequently for heavier usage or severe conditions.

6.3.2 Suspension Pins - Lubricate at least twice per year for normal usage; more frequently for heavier usage or severe conditions.

Application	Part Location	Lubrication	Grade
Air motor	Lubricator	Turbine Oil	ISO VG 32-56 or equivalent
Load chain & pocket wheel	Load chain	Machine or gear oil	ISO VG 46-68 or equivalent
Hook bearings & suspension pins	Top & bottom hook sets	Grease	National Lubricating Grease #3
Gears and Bearings	Gear Section	Grease	National Lubricating Grease #2

7.0 Maintenance and Handling

7.1 Load Limiter

- 7.1.1 The purpose of the load limiter is to prevent using the hoist in an overload situation. When lifting, the hoist will stop automatically if the load is above the rated capacity of the hoist.
- 7.1.2 The adjustment is factory set to actuate at approximately 125% of rated capacity (based on supply air pressure of 90 PSI). Note: the load limiter may need adjustment to compensate for air supply pressures significantly less than 90 PSI.

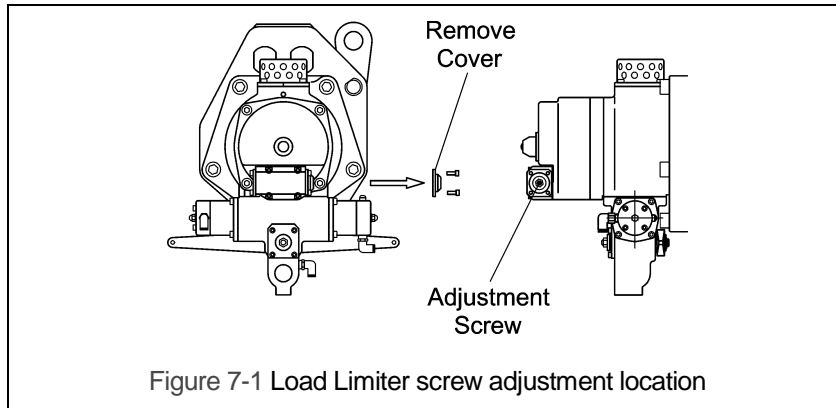

7.1.3 Adjustment Procedure

- 1) Before proceeding with the load limiter adjustment, note the following:
 - a. **⚠WARNING** Adjusting the load limiter involves operating the hoist. Personnel involved in the adjustment procedure should read, understand, and follow Section 4, "Operation".
 - b. For the adjustment procedure, the hoist should be connected to an air supply (see Section 3.1) and it should initially be without a load on its hook.
 - c. Start this procedure with an unloaded hoist. All adjustments to the load limiter should be made with the load in a resting position so that the load chain is not tensioned.
 - d. For the adjustment procedure: OUT means the counter-clockwise (CCW) direction, and IN means the clockwise (CW) direction.
 - e. The pressure of the air supply at the hoist's inlet port (acceptable range is 60 to 90 PSI) affects the performance of your air hoist, including the actuation point of the load limiter. Therefore, ensure that during the adjustment procedure the air pressure at the hoist's inlet port is the same as that which the hoist will experience in normal operation. The relationship between air supply pressure and load limiter actuation is:
 - For a given load limiter setting, as pressure decreases, the actuation point increases.
 - f. When the load limiter is adjusted and working properly, the hoist will operate and lift the load a short distance before the load limiter automatically stops lifting.
- 2) Refer to Figure 7-1. Loosen the lock nut and slowly turn the adjustment screw OUT until it is loose and no longer is in contact with the internal load limiter spring – as this occurs the screw should become easier to turn. Stop turning the screw once it is loose and easier to turn.
- 3) Turn the adjustment screw IN just enough so that it begins to contact the internal load limiter spring – as this occurs the screw should become slightly harder to turn.

- 4) Put a load equal to the desired actuation point on the hoist's hook (do not exceed 125% of the hoist's rated capacity). Begin to slowly lift the load, then increase the lifting speed. Return the load to its resting position so the load chain is not under tension.
- 5) If the load limiter prevents lifting, turn the adjustment screw IN one full turn.
- 6) Repeat steps 4 and 5 until the load limiter allows lifting.
- 7) Turn the adjustment screw OUT $\frac{3}{4}$ of a turn.
- 8) Attempt to lift the rated capacity load again, beginning slowly, then increasing the lifting speed.
- 9) If the load limiter does not allow lifting, then turn the adjustment screw IN $\frac{1}{4}$ turn.
- 10) Repeat steps 8 and 9 until the load limiter allows lifting.
- 11) Turn the adjustment screw IN $\frac{1}{4}$ turn. Then, while holding the adjustment screw, tighten the lock nut to secure the setting.

7.2 Brake

7.2.1 For Load Brake setup and adjustment procedure consult factory.

7.2.2 Inspect the brake disc in accordance with Section 5.7, Table 5-3.

7.2.3 The following is the hoist brake inspection procedure. Refer to Figure 7-2.

- 1) **⚠ WARNING** HAZARDOUS AIR PRESSURE IS PRESENT IN THE HOIST, IN THE SUPPLY OF COMPRESSED AIR TO THE HOIST, AND IN THE CONNECTIONS BETWEEN COMPONENTS. Shut off the air supply and stop the airflow completely. Lock out and tag out in accordance with ANSI Z244.1 "Personnel Protection -Lockout/Tagout of Energy Sources".
- 2) Do NOT turn or remove the brake adjustment screw located in the center of the brake cover.
- 3) Gradually back out all four hex socket cap screws from brake cover to slowly decrease spring tension of brake piston against brake disc.
- 4) Remove brake cover from the motor housing top of gear case. Keep brake piston, springs, seals, etc. together inside the brake cover.
- 5) Remove brake disc for inspection and measurement. Refer to "Motor Brake" in Table 5-3, "Hoist Inspection Methods and Criteria".
- 6) Prior to reassembly, clean all surfaces of debris, dirt and loose paint.
- 7) Reassemble in reverse order. Torque all mounting hardware evenly during the reassembly process.

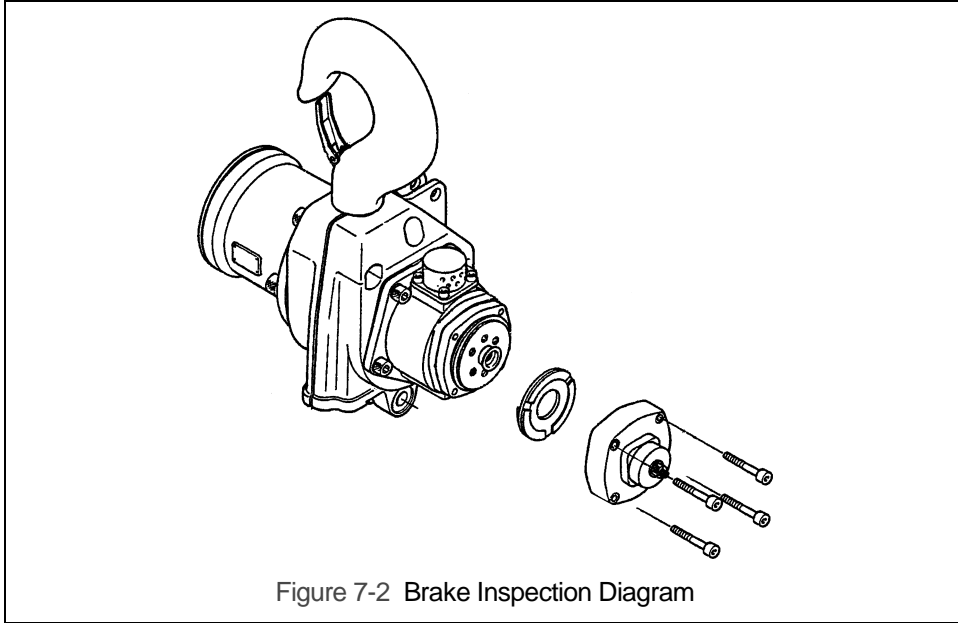

7.3 Load Chain

7.3.1 Lubrication and Cleaning

- Clean the chain with an acid-free cleaning solution. The load chain should be kept clean and lubricated.
- Lubrication - Clean and lubricate the load chain per Section 6 at least once every 3 months for normal usage. Clean and lubricate more frequently for heavier usage or severe conditions.

7.3.2 Replacement

- 1) **⚠ CAUTION** An air supply line must be connected to the hoist in order to perform the following procedures. The hoist must be accessible and must be hanging from the top hook assembly.
- 2) **⚠ WARNING** Be certain that the replacement chain is obtained from Harrington and is the exact size, grade and construction as the original chain.
- 3) **⚠ CAUTION** When replacing load chain, check for wear on mating parts, i.e. Load Sheave, Chain Guides and Idle Sheave, and replace parts if necessary. Remove old chain. Remove hook set assemblies, limit locks, stoppers and end connections from the chain for reuse on new chain. If the load chain is being replaced due to damage or wear out, prevent its reuse by destroying the old chain.
- 4) Remove the existing Load Chain – Lower the bottom hook assembly until it rests on the ground or is supported by some other means. Disconnect the no-load and load end of the load chain from the hoist. Run the hoist in the down direction to remove the chain from the hoist body.
- 5) Run the hoist in the up or down direction until the load sheave is positioned as shown in Figure 7-3.
- 6) Without operating the hoist, tie a wire to the end of the new load chain, then thread the wire through the hoist over the load sheave. Pull the wire so that the load chain enters the hoist making certain that the first link is a standing link and that its weld is facing away from the centerline of the hoist.

- 7) While pulling on the wire, SLOWLY operate hoist in the DOWN direction to thread the load chain over the load sheave. Make sure the chain feeds smoothly while operating the hoist. If binding occurs, stop and SLOWLY operate the hoist in the up direction to back the chain out, then reorient the load sheave as instructed in step 5 before attempting to reinsert the load chain.
- 8) Operated the hoist in the down direction until sufficient there is sufficient load chain to reeve the hoist.
- 9) Reeve the chain through the bottom hook assembly. Remove the wire from the Load chain and attach the no-load and load end of the load chain to the hoist. Ensure that chain remains free of twists.
- 10) After installation has been completed, perform steps outlined in Section 3.12 "Preoperational Checks and Trial Operation".

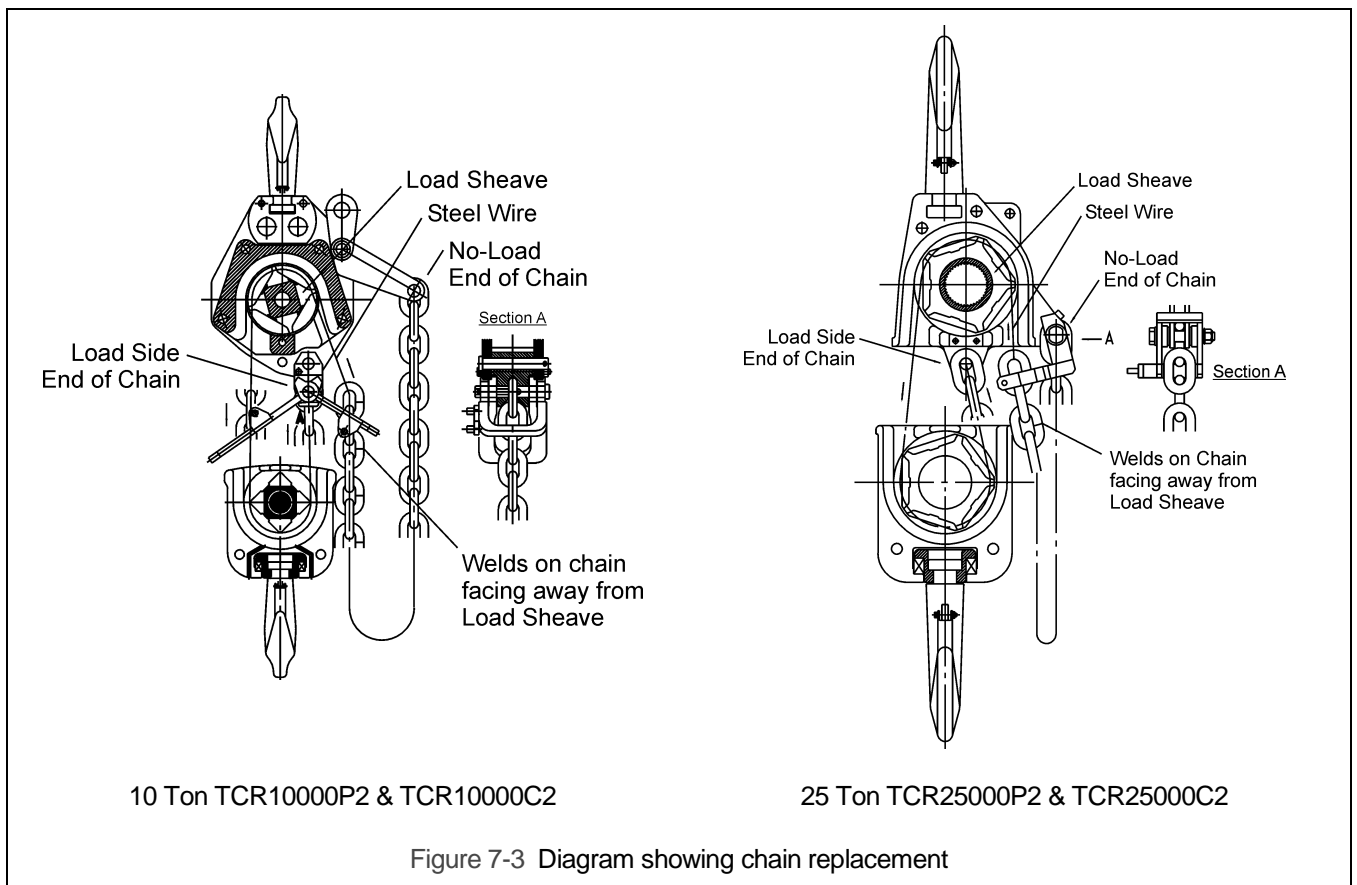

7.4 Pendant

7.4.1 The following procedure covers the installation of a pendant control station.

- 1) Attach the strain relief chain and the three hoses to the pendant station.
- 2) Attach the strain relief chain to the hoist valve body with the socket bolt as shown in Figure 7-4.
- 3) Attach the three hoists to the fittings on the hoist's valve body. Refer to Figure 7-4 and make sure the up, down and supply hoses are attached to the correct locations.
- 4) **NOTICE** When attaching tubes take care not to bend or kink tubing. This will result in the air flow being restricted and poor response to the pendant controls.
- 5) Attach the hoist to supply air. Check for leaks and proper operation.
- 6) **WARNING** The pendant hoses hoist must be connected so that its direction of operation corresponds to the up-and-down lever on the pendant control; i.e. pushing the up button must cause the hook to raise. If the hoist does not operate correctly, shut off the air supply to the hoist and correct the pendant connections.

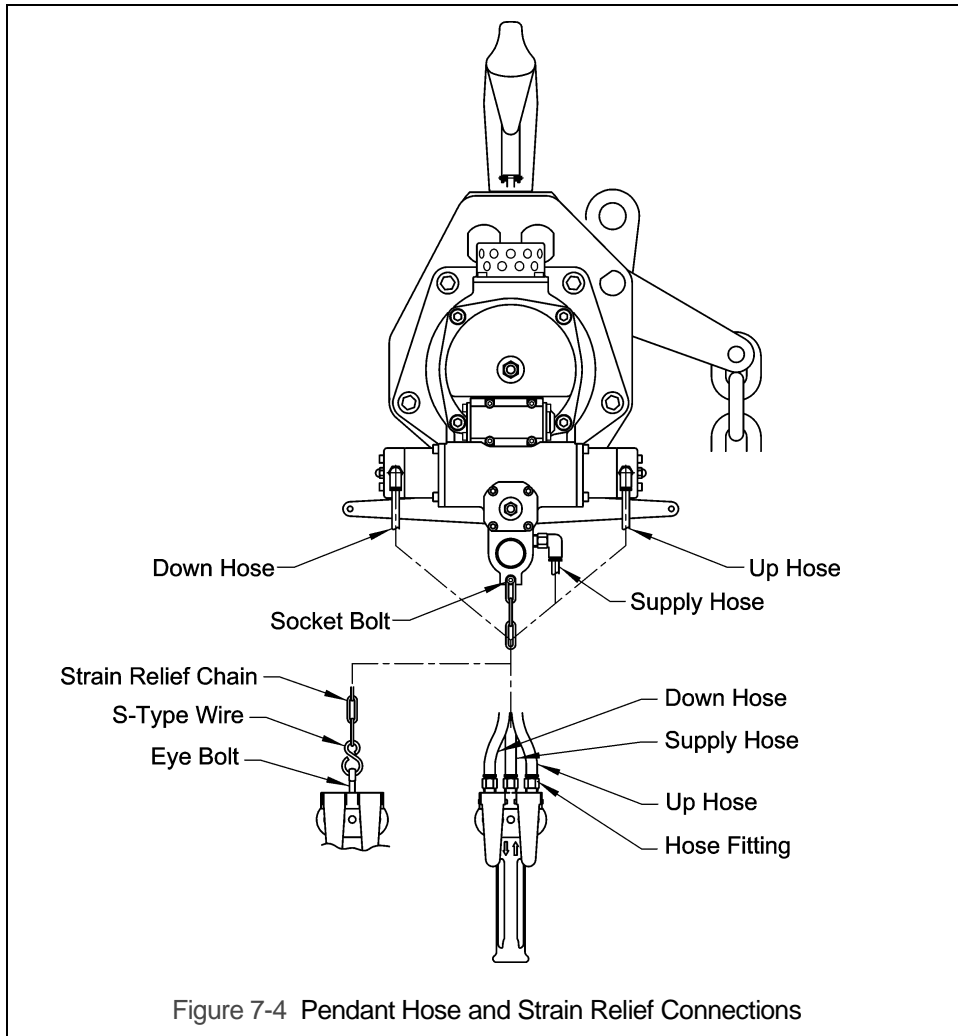

7.5 Storage

7.5.1 Whenever the hoist is to be placed into storage, place extra lubricating oil into the air inlet opening and circulate the air motor before plugging the inlet. Make certain that no debris, dirt or moisture is allowed to enter the air hoist through air inlet opening during preparations for storage.

7.5.2 The storage location should be clean and dry.

7.6 Outdoor Installation

7.6.1 For hoist installations that are outdoors, the hoist should be covered when not in use.

7.6.2 In order to prevent internal corrosion from occurring, the hoist must be operated using proper quality air at least once per week by raising and lowering the hoist one full cycle. Note: the possibility of corrosion in the valve section of the hoist increases for areas where salt air and high humidity are present. For such situations you may need to operate your hoist more often than once per week.

8.0 Troubleshooting

WARNING

HAZARDOUS AIR PRESSURE IS PRESENT IN THE HOIST, IN THE SUPPLY OF COMPRESSED AIR TO THE HOIST, AND IN CONNECTIONS BETWEEN COMPONENTS.

Before performing ANY maintenance on the equipment, de-energize the supply of compressed air to the equipment, and lock and tag the supply device in the de-energized position. Refer to ANSI Z244.1, "Personnel Protection - Lockout/Tagout of Energy Sources."

Only Trained and competent personnel should inspect and repair this equipment.

Table 8-1 Troubleshooting Guide

Symptom	Cause	Remedy
Does not operate	Lack of air pressure or loss of air supply.	Repair or adjust air supply or filters.
	Seizure of Main Spool, Brake Spool, or Air Motor.	Repair at service facility.
	Seizure of brake or brake mechanism fails to release.	Repair at service facility.
	Bending or crimping of pendant control hose(s)	Correct or repair the bend or crimp in control hose(s)
	Hoist is overloaded.	Reduce the load to the rated capacity of hoist.
Lifting speed is slow	Low air pressure at hoist inlet port.	Repair or adjust air supply or filters. Check for air line obstruction.
	Air supply hose or piping is too small.	Replace hose or piping sizes with recommended sizes in Section 3.0.
	Malfunction of brake.	Repair at service facility.
	Bending or crimping of pendant control hose(s)	Correct or repair the bend or crimp in control hose(s)
	Lack of sufficient oil in air supply to hoist	Increase oil in air supply to hoist in accordance with requirements in Section 3.0.
	Exhaust Silencer clogged	Clean or replace.
	Air flow capacity of compressed air system insufficient	Increase air flow capacity of compressed air system to requirements in Section 2.0.
	Air motor vanes or bearings worn	Repair at service facility.
	Air supply to hoist contains dirt or debris	Filter the air supply to the hoist in accordance with the requirements in Section 3.0.
Unable to lift rated load	Lack of air pressure or loss of air supply.	Repair or adjust air supply or filters.
	Improper adjustment of load limiter.	Adjust Load Limiter. See Section 7.1.

Table 8-1 Troubleshooting Guide (continued)		
Symptom	Cause	Remedy
Hoist moving in wrong direction (pendant control)	Pendant control hoses are terminated to incorrect ports on hoist body.	Connect the control tubes in accordance with Section 7.4.
Hoist lowers but will not lift	Hoist is overloaded.	Reduce load to hoist rated capacity.
	Faulty pendant control or control hose(s)	Repair or replace pendant control or control hose(s)
	Lack of air pressure or partial loss of or leakage in air supply.	Repair or adjust air supply or filters.
Hoist continues running after pendant or cord is released	Main Spool sticking	Inject approx. 20 drops of oil into inlet port to lubricate the main spool. If spool still sticks, repair at service facility.
	Valve in Pendant Handle stuck	Repair at service facility
Hoist drifts excessively when hoist is stopped	Brake is not holding.	Repair brake at service facility.

9.0 Warranty

Warranty explanation and terms.

All products sold by Harrington Hoists, Inc. are warranted to be free from defects in material and workmanship from date of shipment by Harrington for the following periods:

- 1 year – Electric and Air Powered Hoists (excluding (N)ER2 Enhanced Features Models), Powered Trolleys, Powered Tiger Track Jibs and Gantries, Crane Components, Below the Hook Devices, Spare / Replacement Parts**
- 2 years – Manual Hoists & Trolleys, Beam Clamps**
- 3 years – (N)ER2 Enhanced Features Model Hoists**
- 5 years – Manual Tiger Track Jibs and Gantries, TNER Pull - Rotor Motor Brake**
- 10 years – (N)ER2 “The Guardian” Smart Brake**

The product must be used in accordance with manufacturer’s recommendations and must not have been subject to abuse, lack of maintenance, misuse, negligence, or unauthorized repairs or alterations.

Should any defect in material or workmanship occur during the above time period in any product, as determined by Harrington Hoist’s inspection of the product, Harrington Hoists, Inc. agrees, at its discretion, either to replace (not including installation) or repair the part or product free of charge and deliver said item F.O.B. Harrington Hoists, Inc. place of business to customer.

Customer must obtain a Return Goods Authorization as directed by Harrington or Harrington’s published repair center prior to shipping product for warranty evaluation. An explanation of the complaint must accompany the product. Product must be returned freight prepaid. Upon repair, the product will be covered for the remainder of the original warranty period. Replacement parts installed after the original warranty period will only be eligible for replacement (not including installation) for a period of one year from the installation date. If it is determined there is no defect, or that the defect resulted from causes not within the scope of Harrington’s warranty, the customer will be responsible for the costs of returning the product.

Harrington Hoists, Inc. disclaims any and all other warranties of any kind expressed or implied as to the product’s merchantability or fitness for a particular application. Harrington will not be liable for death, injuries to persons or property or for incidental, contingent, special or consequential damages, loss or expense arising in connection with the use or inability whatever, regardless of whether damage, loss or expense results from any act or failure to act by Harrington, whether negligent or willful, or from any other reason.

10.0 Parts Information

A complete parts list is available from Harrington Hoists and is supplied separately with your hoist. The parts list is also available from Harrington's web site (www.harringtonhoists.com) or from any Harrington facility (see back cover of this manual).

When ordering Parts, please provide the Hoist code number located on the Hoist nameplate (see fig. below).

Reminder: Per Sections 3.11.6 and 1.1 to aid in ordering Parts and Product Support, record the Hoist code number and serial number in the space provided on the cover of this manual.



Figure 10-1 TCR Nameplate

NOTES

NOTES



Harrington Hoists, Inc.
401 West End Avenue
Manheim, PA 17545

www.harringtonhoists.com

Toll Free: 800-233-3010
Phone: 717-665-2000
Fax: 717-665-2861

TCROM1025-ENG

TCR PARTS LIST

Large Capacity TCR Parts List

10 Ton & 25 Ton Capacity

Code, Lot and Serial Number

WARNING

This equipment should not be installed, operated or maintained by any person who has not read and understood all the contents of this manual. Failure to read and comply with the contents of this manual can result in serious bodily injury or death, and/or property damage.

HARRINGTON
A **KITO** GROUP COMPANY

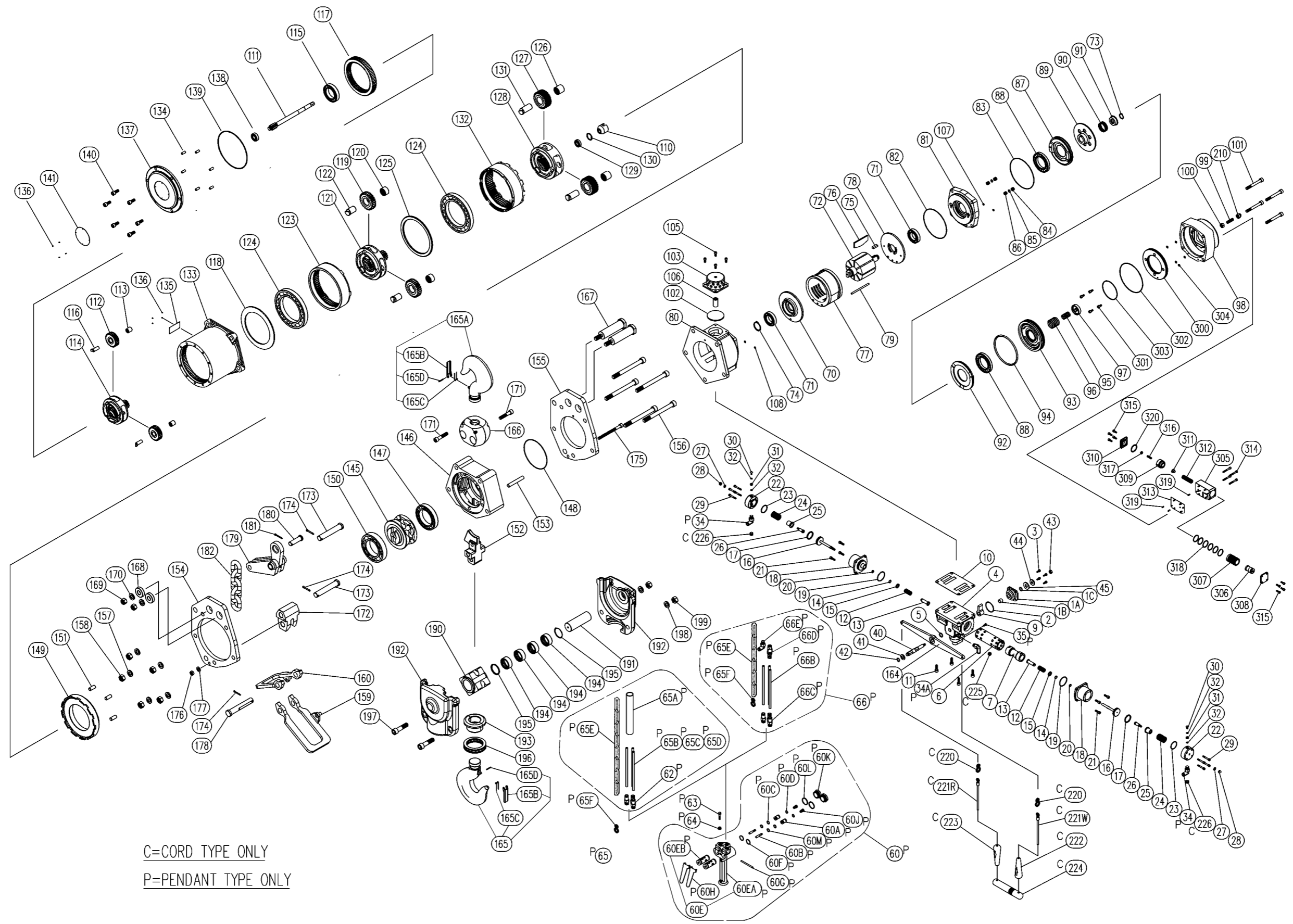

TCR1000

TCR1000C2/P2

Figure Number	Name	Part Number	Parts Per Hoist
1A	METAL BUSHING	TCR426305J90	1
1B	DU BUSHING	TCR130212012	1
1C	O-RING	TCR131101012	1
2	O-RING	TCR131103035	1
3	HEX.SOCKET HEAD CAP SCREW M5X12	9091226	4
4	VALVE BODY	TCR426301A50	1
5	O-RING	TCR131151015	1
6	VALVE BUSHING	TCR426301A60	1
7	THROTTLE VALVE	TCR426301A70	1
9	VALVE SHAFT LEVER	TCR426301J80	1
10	VALVE BODY PACKING	TCR136102097	1
11	HEX.SOCKET HEAD CAP SCREW M8X25	9091273	4
12	THROTTLE VALVE SPRING	TCR130802270	2
13	SPRING GUIDE	TCR426301G20	2
14	RETAINER CLIP	TCR130307011	2
15	SPRING THRUST PLATE	TCR426301R80	2
16	PISTON	TCR426301F80	2
17	O-RING	TCR131151028	2
18	VALVE CAP	TCR426301B30	2
19	O-RING	TCR131103033	2
20	O-RING	TCR131151006	2
21	HEX.SOCKET HEAD CAP SCREW M6X20	9091250	8
22	CAP COVER	TCR426301C80	2
23	O-RING	TCR131103026	2
24	THROTTLE VALVE SPRING (L)	TCR130802271	2
25	SPRING SEAT	TCR426301B50	2
26	SPRING SEAT SHAFT	TCR426301B60	2
27	WASHER	MCR136102095	2
28	HEX. NUT M6	9158703	2
29	HEX.SOCKET HEAD CAP SCREW M5X35	9091232	8
30	ELEMENT HOLDER	TCR426221G50	2
31	ELEMENT	MCR136302010	2
32	PACKING	TCR136102094	4
34	JOINT (ELBOW)	TCR135108102	1
34A	JOINT (STRAIGHT)	TCR135108103	2
35	HEX.SOCKET HEAD CAP SCREW M5X10	9091225	1
40	LIMIT VALVE SHAFT	TCR426305T70	1
41	FLAT WASHER M12	9012515	1

Figure Number	Name	Part Number	Parts Per Hoist
42	RETAINING RING	9047112	1
43	HEX NUT M8	9093424	1
44	LIMIT VALVE SHAFT WASHER	TCR426305V30	1
45	VALVE SHAFT THRUST PLATE	TCR426305G80	1
60	PENDANT VALVE CP	AH420215VBC	1
60A	THROTTLE VALVE	AH420215VB0	2
60B	PUSH ROD	AH420215VC0	2
60C	O-RING	AH131118012	2
60D	O-RING	AH131117013	2
60E	PENDANT VALVE BODY CP	AH420215VRB	1
60EA	PENDANT VALVE BODY	AH420215VR0	1
60EB	BUSHING	AH420214VF0	2
60F	O-RING	AH131103016	2
60G	SPRING PIN 4.5X32	9148160	2
60H	PENDANT VALVE LEVER	AH420210VH0	2
60J	VALVE SPRING	AH130802030	2
60K	PENDANT VALVE CAP	AH420214V10	2
60L	O-RING	TCR131103022	2
60M	RETAINING RING	AH130303004	2
62	JOINT	TCR135108103	3
63	HINGE SCREW M6X30	9044403	1
64	HEX. NUT M6	9093420	1
65	PENDANT HOSE CP	60850	1
65A	HOSE	TCR137225020	1
65B	TUBE BLACK	TCR137208020	FT
65C	TUBE RED	TCR137209020	FT
65D	TUBE WHITE	TCR137210020	FT
65E	STRAIN RELIEF	ES625003	FT
65F	S TYPE WIRE	TCR130802081	1
66	PENDANT HOSE CP	60851	1
66B	HOSE	9013141	3@FT
66C	TUBE FITTING	AH137291310	3
66D	STRAIGHT CONNECTOR	9013151	2
66E	ELBOW CONNECTOR	9013152	1
65E	STRAIN RELIEF	ES625003	FT
65F	S TYPE WIRE	TCR130802081	1
70	FRONT PLATE	TCR426301K70	1
71	BEARING 6007ZZ	9000507	2
72	ROTOR	TCR426301K40	1
73	RETAINING RING	9047120	1
74	RETAINING RING	9047135	1
75	BRAKE WHEEL KEY	TCR130408110	1

TCR1000C2/P2

Figure Number	Name	Part Number	Parts Per Hoist
76	VANE	TCR137102012	8
77	CYLINDER	TCR426301K50	1
78	REAR PLATE	TCR426301K20	1
79	CYLINDER KNOCK	TCR130402008	1
80	CASE	TCR426307K80	1
81	MOTOR COVER	TCR426307N30	1
82	O RING	TCR131103063	1
83	O RING	TCR131103064	1
84	BRAKE VALVE	TCR426301W30	2
85	O RING	TCR131103007	2
86	BRAKE VALVE SPRING	TCR130802272	2
87	BRAKE SHIFTER (M)	TCR426301W80	1
88	BEARING	TCR130116011	2
89	BRAKE DISC	TCR426301P30	1
90	SHIFTER SPRING	TCR130802273	1
91	SHIFTER SPRING SEAT	TCR426301W70	1
92	BRAKE SHIFTER	TCR426301W90	1
93	BRAKE PISTON	TCR426301Q70	1
94	O RING	TCR131101077	1
95	BRAKE SPRING (S)	TCR130802274	1
96	BRAKE SPRING (L)	TCR130802275	1
97	BRAKE SPRING SEAT	TCR426301B70	1
98	BRAKE CASE	TCR426307P20	1
99	HEX.SOCKET SET SCREW M10X35	TCR132310035	1
100	HEX.NUT M10	TCR426301Q90	1
101	HEX.SOCKET HEAD CAP SCREW M10X85	90912140	4
102	SILENCER	TCR137402046	1
103	EXHAUST COVER	TCR426301Q60	1
105	HEX.SOCKET HEAD CAP SCREW M6X14	9091248	4
106	EXHAUST COVER SHAFT	TCR426301U90	1
107	O RING	TCR131103004	2
108	O RING	TCR131101004	2
110	COUPLING	TCR426301L20	1
111	PINION	TCR426301L30	1
112	FIRST IDLE GEAR	TCR426301L80	3
113	NEEDLE BEARING	TCR130131220	3
114	FIRST FRAME	TCR426301M10	1
115	BEARING	9000110	1
116	FIRST IDLE GEAR SHAFT	TCR426301M20	3
117	FIRST INTERNAL GEAR	TCR426301L90	1

Figure Number	Name	Part Number	Parts Per Hoist
118	CONED DISK SPRING	TCR426301L50	1
119	SECOND IDLE GEAR	TCR426301M40	3
120	NEEDLE BEARING	TCR130132520	3
121	SECOND FRAME	TCR426301M70	1
122	SECOND IDLE GEAR SHAFT	TCR426301M50	3
123	SECOND INTERNAL GEAR	TCR426301M60	1
124	BEARING	TCR130116024	2
125	INTERNAL GEAR SPACER	TCR426301K60	1
126	THIRD IDLE GEAR	TCR426301N40	3
127	NEEDLE BEARING	TCR130132530	3
128	THIRD FRAME	TCR426301N70	1
129	BEARING	9000502	1
130	RETAINING RING	9047232	1
131	THIRD IDLE GEAR SHAFT	TCR426301N50	3
132	THIRD INTERNAL GEAR	TCR426301N60	1
133	GEAR CASE	TCR426301N80	1
134	SPRING PIN 8X20	91481117	6
135	BRAND NAME PLATE - H'TON	80103	1
136	RIVET NO.0X3.2	MCR133001110	8
137	GEAR COVER	TCR426301N20	1
138	BEARING	9000202	1
139	O RING	TCR131117166	1
140	HEX. SOCKET HEAD CAP SCREW M10X25	9091294	6
141	NAME PLATE 10 TON	80104	1
145	LOAD SHEAVE	TCR426301R20	1
146	CHAIN GUIDE	TCR426301R30	1
147	BEARING	9000915	1
148	O RING	TCR131103063	1
149	CHAIN GUIDE COVER	TCR426301U80	1
150	BEARING	9001015	1
151	KNOCK PIN	TCR426301L60	3
152	CHAIN SEPARATOR	TCR426303R40	1
153	CHAIN SEPARATOR PIN	TCR426301U40	1
154	MIDDLE PLATE (G)	TCR426303C60	1
155	MIDDLE PLATE (M)	TCR426303C70	1
156	HEX SOCKET HEAD CAP SCREW M16X170	90912145	5
157	SPRING WASHER M16	9012715	5
158	HEX. NUT M16	9093439	5
159	LIMIT LEVER U	TCR426303R60	1
160	LIMIT LEVER D	TCR426303AC0	1
164	CONTROL LEVER	TCR426303L70	1

TCR1000C2/P2

Figure Number	Name	Part Number	Parts Per Hoist
165	HOOK CP	TCR426303S2B	2
165B	HOOK SAFETY CLAW	TCR420890P10	1
165C	HOOK SPRING	TCR130802046	1
165D	SPRING PIN 3X24	TCR130603024	1
166	HOOK END PIECE	TCR426303AH0	1
167	HANGER PIN	TCR426303AG0	2
168	WASHER	TCR426303R50	2
169	U NUT M16	9098516	2
170	SPRING WASHER M16	9012715	2
171	HEX. SOCKET HEAD CAP SCREW M12X60	90912120	2
172	CHAIN SET PLATE	TCR426303X40	1
173	CHAIN SET PLATE SHAFT	TCR426301X50	2
174	SPLIT PIN 5X35	9009445	3
175	HEX. SOCKET HEAD CAP SCREW M10X130	90912141	1
176	U NUT M10	9098508	1
177	PLAIN WASHER M10	9012514	1
178	CHAIN SET SPINDLE	TCR426303X60	1
179	CHAIN END CONNECTOR	TCR426301X70	1
180	CHAIN END PIN	TCR426301X80	1
181	SPLIT PIN 4X32	9009436	1
182	LOAD CHAIN	LCTCR10000	FT
190	FREE CHAIN WHEEL	TCR426303U20	1
191	FREE WHEEL PIN	TCR426303AJ0	1
192	YOKE	TCR426303Y60	1
193	HOOK SLIDE RING	TCR426303X90	1
194	NEEDLE BEARING	TCR130134020	4
195	SEAL	TCR131212040	2
196	THRUST BEARING	TCR130121114	1
197	HEX. SOCKET HEAD CAP SCREW M16X75	90912144	2
198	SPRING WASHER M16	9012715	2
199	HEX. NUT M16	9093439	2
210	DOMED CAP NUT M10	9158705	1
220	S TYPE WIRE	TCR130802081	2
221R	RED CORD	9013102	FT
221W	WHITE CORD	9013101	FT
222	GRIP (W)	AH136602625	1
223	GRIP (R)	AH136602626	1
224	HANDLE	AH136602627	1

Figure Number	Name	Part Number	Parts Per Hoist
225	HEX. SOCKET HEAD CAP PLUG	TCR134901002	1
226	HEX. SOCKET HEAD CAP PLUG	TCR420875BJ0	2
300	CHAMBER CAP	TCR426307AL0	1
301	HEX. SOCKET HEAD CAP SCREW M6X14	9091248	4
302	O RING	TCR131103063	1
303	O RING	MCR131103051	1
304	O RING	TCR131103005	5
305	VALVE BOX	TCR426307AM0	1
306	LIMIT SPOOL	TCR426307AN0	1
307	LIMIT SPOOL BUSHING	TCR426307AP0	1
308	BOX COVER	TCR426307AQ0	1
309	LIMIT RETAINER	TCR426307AR0	1
310	ADJUST COVER	TCR426307AS0	1
311	SPRING SEAT	TCR426307Z50	1
312	SPRING 13X64X2	TCR130802276	1
313	LIMIT GASKET	TCR136102170	1
314	HEX. SOCKET HEAD CAP SCREW M5X40	9091233	4
315	HEX. SOCKET HEAD CAP SCREW M5X14	9091227	8
316	HEX. SOCKET SET SCREW M6X25	TCR132306025	1
317	HEX. NUT M6	9043904	1
318	O-RING	TCR131103022	6
319	PARALLEL PIN 4X10	TCR130406005	3
320	RETAINING RING	9047232	1

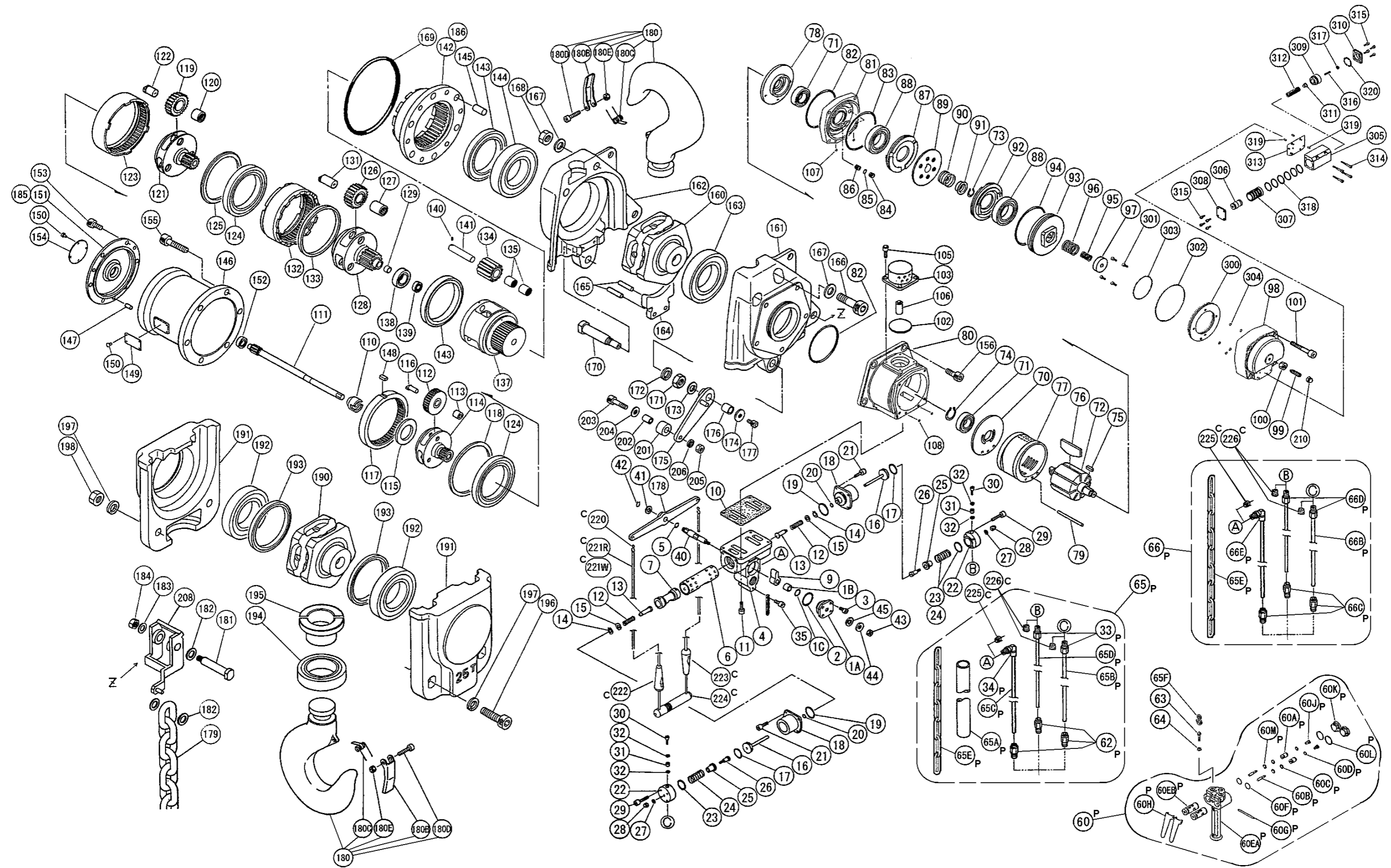

TCR25000

TCR25000C2/P2

Figure Number	Name	Part Number	Parts Per Hoist
1A	METAL BUSHING	TCR426305J90	1
1B	DU BUSHING	TCR130212012	1
1C	O RING	TCR131101012	1
2	O RING	TCR131103035	1
3	HEX.SOCKET HEAD CAP SCREW M5X12	9091226	4
4	VALVE BODY	TCR426301A50	1
5	O RING	TCR131151015	1
6	VALVE BUSHING	TCR426301A60	1
7	THROTTLE VALVE	TCR426301A70	1
9	VALVE SHAFT LEVER	TCR426301J80	1
10	VALVE BODY PACKING	TCR136102097	1
11	HEX.SOCKET HEAD CAP SCREW M8X25	9091273	4
12	THROTTLE VALVE SPRING (S)	TCR130802270	2
13	SPRING GUIDE (S)	TCR426301G20	2
14	RETAINER CLIP	TCR130307011	2
15	SPRING THRUST PLATE	TCR426301R80	2
16	PISTON	TCR426301F80	2
17	O RING	TCR131151028	2
18	VALVE CAP	TCR426301B30	2
19	O RING	TCR131103033	2
20	O RING	TCR131151006	2
21	HEX.SOCKET HEAD CAP SCREW M6X20	9091250	8
22	CAP COVER	TCR426301C80	2
23	O RING	TCR131103026	2
24	THROTTLE VALVE SPRING (L)	TCR130802271	2
25	SPRING SEAT	TCR426301B50	2
26	SPRING SEAT SHAFT	TCR426301B60	2
27	WASHER	MCR136102095	2
28	HEX. NUT M6	9158703	2
29	HEX.SOCKET HEAD CAP SCREW M5X35	9091232	8
30	ELEMENT HOLDER	TCR426221G50	2
31	ELEMENT	MCR136302010	2
32	PACKING	TCR136102094	4
33	JOINT (STRAIGHT)	TCR135108103	2
34	JOINT (ELBOW)	TCR135108102	1
35	HEX.SOCKET HEAD CAP SCREW M5X10	9091225	1
40	LIMIT VALVE SHAFT	TCR426305T70	1
41	FLAT WASHER M12	9012515	1
42	RETAINING RING	9047112	1
43	HEX. NUT M8	9093424	1
44	LIMIT VALVE SHAFT WASHER	TCR426305V30	1

Figure Number	Name	Part Number	Parts Per Hoist
45	VALVE SHAFT THRUST PLATE	TCR426305G80	1
60	PENDANT VALVE CP	AH420215VBC	1
60A	THROTTLE VALVE	AH420215VB0	2
60B	PUSH ROD	AH420215VC0	2
60C	O-RING	AH131118012	2
60D	O-RING	AH131117013	2
60E	PENDANT VALVE BODY CP	AH420215VRB	1
60EA	PENDANT VALVE BODY	AH420215VR0	1
60EB	BUSHING	AH420214VF0	2
60F	O-RING	AH131103016	2
060G	SPRING PIN 4.5X32	9148160	2
60H	PENDANT VALVE LEVER	AH420210VH0	2
60J	VALVE SPRING	AH130802030	2
60K	PENDANT VALVE CAP	AH420214V10	2
60L	O-RING	TCR131103022	2
60M	RETAINING RING	AH130303004	2
62	JOINT	TCR135108103	3
63	HINGE SCREW M6X30	9044403	1
64	HEX. NUT M6	9093420	1
65	PENDANT HOSE CP	60850	1
65A	HOSE	TCR137225020	FT
65B	TUBE BLACK 8X6X2M	TCR137208020	FT
65C	TUBE RED 8X6X2M	TCR137209020	FT
65D	TUBE WHITE 8X6X2M	TCR137210020	FT
65E	STRAIN RELIEF	ES625003	FT
65F	S TYPE WIRE	TCR130802081	1
66	PENDANT HOSE CP	60851	1
66B	HOSE	9013141	3@FT
66C	TUBE FITTING	AH137291310	3
66E	JOINT (ELBOW)	9013152	1
66D	JOINT (STRAIGHT)	9013151	2
65E	STRAIN RELIEF	ES625003	FT
65F	S TYPE WIRE	TCR130802081	1
70	FRONT PLATE	TCR426301K70	1
71	BEARING	9000507	2
72	ROTOR	TCR426301K40	1
73	RETAINING RING	9047120	1
74	RETAINING RING	9047135	1
75	BRAKE WHEEL KEY	TCR130408110	1
76	VANE	TCR137102012	8
77	CYLINDER	TCR426301K50	1
78	REAR PLATE	TCR426301K20	1
79	CYLINDER KNOCK	TCR130402008	1
80	CASE	TCR426307K80	1

TCR25000

Figure Number	Name	Part Number	Parts Per Hoist
81	MOTOR COVER	TCR426307N30	1
82	O RING	TCR131103063	2
83	O RING	TCR131103064	1
84	BRAKE VALVE	TCR426301W30	2
85	O RING	TCR131103007	2
86	BRAKE VALVE SPRING	TCR130802272	2
87	BRAKE SHIFTER (M)	TCR426301W80	1
88	BEARING	TCR130116011	2
89	BRAKE DISC	TCR426301P30	1
90	SHIFTER SPRING	TCR130802273	1
91	SHIFTER SPRING SEAT	TCR426301W70	1
92	BRAKE SHIFTER (S)	TCR426301W90	1
93	BRAKE PISTON	TCR426301Q70	1
94	O RING	TCR131101077	1
95	BRAKE SPRING (S)	TCR130802274	1
96	BRAKE SPRING (L)	TCR130802275	1
97	BRAKE SPRING SEAT	TCR426301B70	1
98	BRAKE CASE	TCR426307P20	1
99	HEX.SOCKET SET SCREW M10X35	TCR132310035	1
100	HEX.NUT M10	TCR426301Q90	1
101	HEX.SOCKET HEAD CAP SCREW M10X85	90912140	4
102	SILENCER	TCR137402046	1
103	EXHAUST COVER	TCR426301Q60	1
105	HEX.SOCKET HEAD CAP SCREW M6X14	9091248	4
106	EXHAUST COVER SHAFT	TCR426301U90	1
107	O RING	TCR131103004	2
108	O RING	TCR131101004	2
110	COUPLING	TCR426305L20	1
111	PINION	TCR426305L30	1
112	FIRST IDLE GEAR	TCR426305L80	3
113	NEEDLE BEARING	TCR130131220	3
114	FIRST FRAME	TCR426305M10	1
115	BEARING	TCR130116011	1
116	FIRST IDLE GEAR SHAFT	TCR426305M20	3
117	FIRST INTERNAL GEAR	TCR426305L90	1
118	CONED DISK SPRING	TCR426305L40	1
119	SECOND IDLE GEAR	TCR426301M40	3
120	NEEDLE BEARING	TCR130132520	3
121	SECOND FRAME	TCR426301M70	1
122	SECOND IDLE GEAR SHAFT	TCR426301M50	3
123	SECOND INTERNAL GEAR	TCR426301M60	1
124	BEARING	TCR130116024	2
125	INTERNAL GEAR SPACER	TCR426301K60	1

Figure Number	Name	Part Number	Parts Per Hoist
126	THIRD IDLE GEAR	TCR426301N40	3
127	NEEDLE BEARING	TCR130132530	3
128	THIRD FRAME	TCR426305N71	1
129	PINION SPACER	TCR426305AD0	1
131	THIRD IDLE GEAR SHAFT	TCR426301N50	3
132	THIRD INTERNAL GEAR	TCR426301N60	1
133	THIRD INTERNAL GEAR SPACER	TCR426305N91	1
134	LAST IDLE GEAR	TCR426305V41	3
135	NEEDLE BEARING	TCR130132130	6
137	LAST FRAME	TCR426305V62	1
138	BEARING	9000107	1
139	BEARING	9000502	1
140	PARALLEL PIN 4X10	TCR130406005	3
141	LAST IDLE GEAR SHAFT	TCR426305V71	3
142	LAST INTERNAL GEAR	TCR426305V81	1
143	BEARING	9001212	2
144	BEARING	9000924	1
145	KNOCK PIN	TCR426305L61	6
146	GEAR CASE	TCR426305N80	1
147	SPRING PIN 8X20	91481117	3
148	INTERNAL GEAR KEY	TCR130408111	1
149	BRAND NAME PLATE	80103	1
150	RIVET NO.0X3.2	MCR133001110	8
151	GEAR COVER	TCR426305N20	1
152	BEARING	9000202	1
153	HEX. SOCKET HEAD CAP SCREW M10X25	9091294	6
154	NAME PLATE 25TON	80105	1
155	HEX. SOCKET HEAD CAP SCREW M16X70	90912143	6
156	HEX. SOCKET HEAD CAP SCREW M16X35	90912142	5
160	LOAD SHEAVE	TCR426305R22	1
161	SIDE PLATE (M)	TCR426305D50	1
162	SIDE PLATE (G)	TCR426305D61	1
163	BEARING 6220DDU	90010xx	1
164	CHAIN SEPARATOR	TCR426305R40	1
165	SPRING PIN 12X45	91481168	2
166	HEX. SOCKET HEAD CAP SCREW M24X90	90912146	2
167	SPRING WASHER M24 NARROW	9012719	4
168	HEX. NUT M24	9093445	2
169	O-RING	TCR131103195	1
170	CHAIN SET SPINDLE	TCR426305X60	1
171	HEX. NUT M24	9043911	1
172	SPRING WASHER M24	9012719	1

TCR25000

Figure Number	Name	Part Number	Parts Per Hoist
173	WASHER M20	9012519	1
174	LIMIT LEVER THRUST PLATE	TCR426305W60	1
175	LIMIT LEVER	TCR426305R61	1
176	DU BUSHING	TCR130220025	1
177	HEX. SOCKET HEAD CAP SCREW M10X15	9091292	1
178	CONTROL LEVER	TCR426305L70	1
179	LOAD CHAIN	LCTCR25000	FT
180	HOOK CP	TCR426305S2B	2
180B	HOOK SAFETY CLAW	TCR420745P10	1
180C	HOOK SPRING	TCR130802060	1
180D	HEX. SOCKET HEAD CAP SCREW M8X45	9091277	1
180E	U NUT M8	9098506	1
181	CHAIN END PIN	TCR426305X81	1
182	WASHER M24	9012521	3
183	WASHER M20	9012519	1
184	U NUT M-20	9098520	1
185	GEAR COVER PACKING	TCR136102100	1
186	INTERNAL GEAR PACKING (N)	TCR136102139	1
190	FREE CHAIN WHEEL	TCR426305U20	1
191	YOKE	TCR426305Y60	2
192	BEARING	TCR130125220	2
193	OIL SEAL	TCR131203150	2
194	THRUST BEARING	TCR130121220	1
195	HOOK THRUST RING	TCR426305X90	1
196	HEX. SOCKET HEAD CAP SCREW M24X90	90912146	2
197	SPRING WASHER M24 NARROW	9012719	4
198	HEX. NUT M24	9093445	2
201	LIMIT ROLLER	TCR426305F20	1
202	LIMIT SPACER	TCR426305F30	1
203	HEX. BOLT M12X50	9093374	1
204	PLAIN WASHER M12	9012515	1
205	HEX. NUT M12	9093433	1
206	SPRING WASHER M12	9012713	1
208	LIMIT LEVER (D)	TCR426305AC0	1
210	DOMED CAP NUT M10	9158705	1
220	S TYPE WIRE	TCR130802081	2
221R	THROTTLE VALVE CHANGE CORD - RED	9013102	6
221W	THROTTLE VALVE CHANGE CORD - WHITE	9013101	6
222	GRIP (W)	AH136602625	1
223	GRIP (R)	AH136602626	1
224	HANDLE	AH136602627	1
225	HEX. SOCKET HEAD CAP PLUG	TCR134901002	1

Figure Number	Name	Part Number	Parts Per Hoist
226	HEX. SOCKET HEAD CAP PLUG	TCR420875BJ0	2
300	CHAMBER CAP	TCR426307AL0	1
301	HEX.SOCKET HEAD CAP SCREW M6X14	9091248	4
302	O RING	TCR131103063	1
303	O RING	MCR131103051	1
304	O RING	TCR131103005	5
305	VALVE BOX	TCR426307AM0	1
306	LIMIT SPOOL	TCR426307AN0	1
307	LIMIT SPOOL BUSHING	TCR426307AP0	1
308	BOX COVER	TCR426307AQ0	1
309	LIMIT RETAINER	TCR426307AR0	1
310	ADJUST COVER	TCR426307AS0	1
311	SPRING SEAT	TCR426307Z50	1
312	SPRING 13X64X2	TCR130802276	1
313	LIMIT GASKET	TCR136102170	1
314	HEX. SOCKET HEAD CAP SCREW M5X40	9091233	4
315	HEX. SOCKET HEAD CAP SCREW M5X14	9091227	8
316	HEX. SOCKET SET SCREW M6X25	TCR132306025	1
317	HEX. NUT M6	9043904	1
318	O-RING	TCR131103022	6
319	PARALLEL PIN 4X10	TCR130406005	3
320	RETAINING RING	9047232	1



Harrington Hoists, Inc.
401 West End Avenue
Manheim, PA 17545

www.harringtonhoists.com

Toll Free: 800-233-3010
Phone: 717-665-2000
Fax: 717-665-2861

TCRPL1025-ENG