

LB Lever Hoists

HARRINGTON
A KITO GROUP COMPANY

Setting new standards for the industry

Harrington's LB lever hoists have been completely redesigned to provide the operator with all of the features needed in one hoist. Our best just got better. As the leader in this hoist market, we studied the needs of the many industries using our lever hoists and then designed all of these important features into our new model. For your day-to-day maintenance and service work or the heavy-duty construction jobs, the Harrington LB lever hoist is always the right choice.



MODEL: LB015

Look for the advantages

- Improved design
- Compact size
- Lighter weight
- Lower headroom
- Easy to operate, transport and store
- Trouble-free maintenance

Dependability

- Heavy-duty all-steel construction
- Weston-style mechanical load brake
- Spring-loaded free wheel mechanism
- Nickel-plated corrosion-resistant load chain

Capacity Range

- 3/4, 1, 1-1/2, 2, 3, 6 and 9 Ton
- Plus the industry's first 2-3/4 Ton

Applications

- Maintenance and repairs
- Construction, mining and manufacturing
- Shipbuilding

Ask your local sales representative or call our Customer Service staff for friendly and expert advice on models and options.

LB LEVER HOISTS—SPECIFICATIONS AND DIMENSIONS

Cap. (Tons)	Product Code	Headroom C (in)	Std. Lift (ft)	Pull to Lift Load* (lbs)	a (in)	b (in)	D* (in)	e (in)	f (in)	g (in)	Load Chain Dia. (mm) x Chain Fall Lines	Net Weight (lbs)	Shipping Weight Approx. (lbs)	Weight for Additional One Foot of Lift (lbs)						
3/4	LB008	11.0	5	54 (36)	5.7	4.7	9.6 (14.4)	3.8	1.6	0.9	5.6 x 1	13	13	0.5						
1	LB010	11.8		72 (46)								13	14							
1 1/2	LB015	13.2		64 (45)	6.3	5.0		3.9	1.5	1.3	7.1 x 1	18	18	0.7						
2	LB020	14.8		59 (42)	6.8	5.9	10.4 (14.4)	4.0	1.8	1.4	8.8 x 1	25	26	1.1						
2 3/4	LB028			81 (57)																
3	LB030	15.6		69	6.3	16.3 (16.9)		4.4	2.3	2.0	10.0 x 1	33	35	1.5						
6	LB060	21.3		72	7.5		8.5								4.1	2.9	10.0 x 2	57	60	3.2
9	LB090	26.8		78	12.0		10.0 x 3													

*Figures in parentheses are for hoists with the optional load limit warning handle.

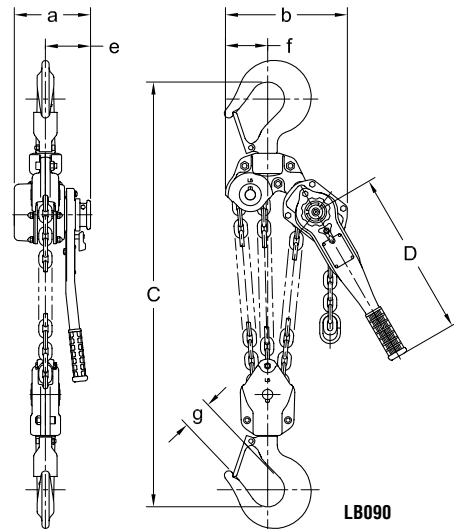
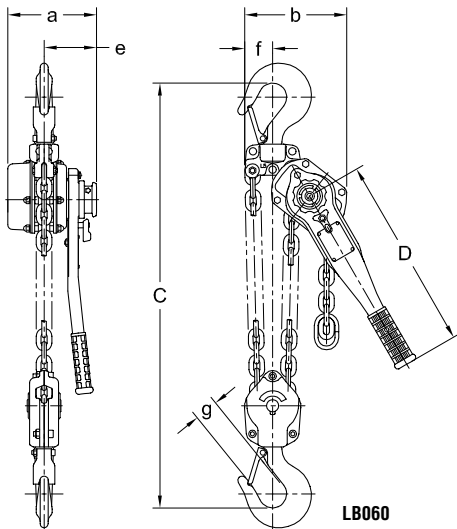
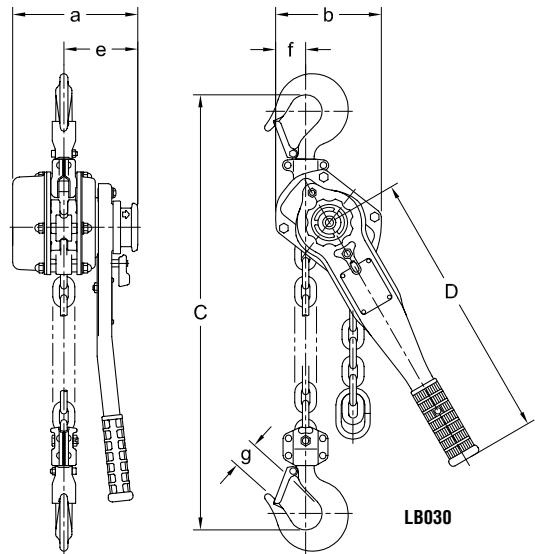
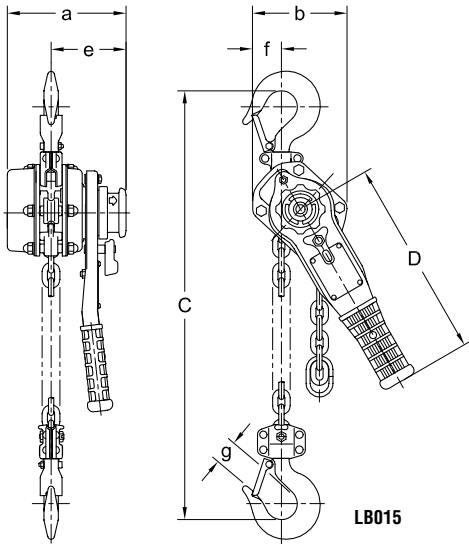



Easy to operate — improved design



Easy to transport — compact and lightweight

LB LEVER HOISTS—WITH SLIP CLUTCH

LB Lever Hoists with the Slip Clutch option will prevent the hoist from being used to lift damaging loads beyond rated capacity. The Slip Clutch is factory installed and is clearly identified on the hoist nameplate and with a black free chain knob.

- Capacities available – 3/4, 1-1/2, 3 and 6 Ton
- Heavy-duty all-steel construction
- Spring-loaded free wheel mechanism
- Weston-style load brake
- Totally enclosed brake with slip clutch
- Nickel-plated, corrosion-resistant load chain



MODEL: LB-SC

LB LEVER HOISTS—OPTIONAL ACCESSORIES



Point Load or Shipyard Hooks



Load Limit Warning Handle



Top Hook Extender

Consult Customer Service for full details.

Harrington Hoists, Inc.
401 West End Avenue
Manheim, PA 17545



Toll Free: 800-233-3010
Phone: 717-665-2000
Fax: 717-665-2861

www.harringtonhoists.com

Rev 3 Copyright © 2003 9-18
Item No. SS-LB

Specifications and dimensions are
subject to change without notice.