OWNER'S MANUAL

ELECTRIC WIRE ROPE TROLLEY HOIST RH ADVANTAGE SERIES

5, 7½ and 10T Capacity

Hoist Code and Serial Number

⚠ WARNING

This equipment should not be installed, operated or maintained by any person who has not read and understood all the contents of this manual. Failure to read and comply with the contents of this manual can result in serious bodily injury or death, and/or property damage.

HARRINGTON
A **KITO** GROUP COMPANY

Table of Contents

Section	Page Number
1.0 Important Information and Warnings.....	4
1.1 Terms and Summary	
1.2 Warning Tags and Labels	
2.0 Technical Information	8
2.1 Specifications	
2.2 Dimensions	
3.0 Pre-operational Procedures.....	13
3.1 General Information	
3.2 Handling	
3.3 Mounting Location	
3.4 Assembly, Adjustments and Mounting	
3.5 Electrical Connections	
3.6 Reeving and Adjustments	
3.7 Pre-operational Checks and Trial Operation	
4.0 Operation.....	24
4.1 Introduction	
4.2 Shall's and Shall Not's for Operation	
4.3 Hoist and Trolley Controls	
5.0 Inspection.....	28
5.1 General	
5.2 Inspection Classification	
5.3 Frequent Inspection	
5.4 Periodic Inspection	
5.5 Occasionally Used Trolley Hoists	
5.6 Inspection Records	
5.7 Inspection Methods and Criteria	

Section	Page Number
6.0 Maintenance & Handling.....	37
6.1 Lubrication	
6.2 Hoist Motor Brake	
6.3 Trolley Motor Brake	
6.4 Wire Rope	
6.5 Storage	
6.6 Outdoor Installation	
7.0 Troubleshooting.....	48
8.0 Warranty.....	51
9.0 Parts List	53

1.0 Important Information and Warnings

1.1 Terms and Summary

This manual provides important information for personnel involved with the installation, operation and maintenance of this product. Although you may be familiar with this or similar equipment, it is strongly recommended that you read this manual before installing, operating or maintaining the product.

Danger, Warning, Caution and Notice - Throughout this manual there are steps and procedures that can present hazardous situations. The following signal words are used to identify the degree or level of hazard seriousness.

⚠ DANGER Danger indicates an imminently hazardous situation which, if not avoided, **will** result in **death or serious injury**, and property damage.

⚠ WARNING Warning indicates an imminently hazardous situation which, if not avoided, **could** result in **death or serious injury**, and property damage.

⚠ CAUTION Caution indicates a potentially hazardous situation which, if not avoided, **may** result **minor or moderate injury** or property damage.

NOTICE Notice is used to notify people of installation, operation, or maintenance information which is important but not directly hazard-related.

⚠ CAUTION

These general instructions deal with the normal installation, operation, and maintenance situations encountered with the equipment described herein. The instructions should not be interpreted to anticipate every possible contingency or to anticipate the final system, crane, or configuration that uses this equipment. For systems using the equipment covered by this manual, the supplier and owner of the system are responsible for the system's compliance with all applicable industry standards, and with all applicable federal, state and local regulations/codes.

This manual includes instructions and parts information for the RH Advantage trolley hoist. Therefore, all instructions and parts information may not apply to any one type or size of specific trolley hoist. Disregard those portions of the instructions that do not apply.

Record your trolley hoist's Product Code and Serial Number on the front cover of this manual for identification and future reference to avoid referring to the wrong manual for information or instructions on installation, operation, inspection, maintenance, or parts.

Use only Harrington authorized replacement parts in the service and maintenance of this trolley.

WARNING

Equipment described herein is not designed for and **MUST NOT** be used for lifting, supporting, or transporting people, or for lifting or supporting loads over people.

Equipment described herein should not be used in conjunction with other equipment unless necessary and/or required safety devices applicable to the system, crane, or application are installed by the system designer, system manufacturer, crane manufacturer, installer, or user.

Modifications to upgrade, rerate, or otherwise alter this equipment shall be authorized only by the original equipment manufacturer.

Equipment described herein may be used in the design and manufacture of cranes or monorails. Additional equipment or devices may be required for the crane and monorail to comply with applicable crane design and safety standards. The crane designer, crane manufacturer, or user is responsible to furnish these additional items for compliance. Refer to ANSI/ASME B30.17, "Safety Standard for Top-Running Single Girder Cranes"; ANSI/ASME B30.2 "Safety Standard for Top-Running Double-Girder Cranes"; and ANSI/ASME B30.11 "Safety Standard for Underhung Cranes and Monorails".

Hoists, trolleys and cranes, used to handle hot molten material may require additional equipment or devices. Refer to ANSI Z241.2, "Safety Requirements for Melting and Pouring of Metals in the Metalcasting Industry".

Electrical equipment described herein is designed and built in compliance with Harrington's interpretation of ANSI/NFPA 70, "National Electrical Code". The system designer, system manufacturer, crane designer, crane manufacturer, installer, or user is responsible to assure that the installation and associated wiring of these electrical components is in compliance with ANSI/NFPA 70, and all applicable Federal, State and Local Codes.

Failure to read and comply with any one of the limitations noted herein can result in serious bodily injury or death, and/or property damage.

DANGER

HAZARDOUS VOLTAGES ARE PRESENT IN THE CONTROL BOX, OTHER ELECTRICAL COMPONENTS, AND CONNECTIONS BETWEEN THESE COMPONENTS.

Before performing ANY mechanical or electrical maintenance on the equipment, de-energize (disconnect) the main switch supplying power to the equipment; and lock and tag the main switch in the de-energized position. Refer to ANSI Z244.1, "Personnel Protection – Lockout/Tagout of Energy Sources".

Only trained and competent personnel should inspect and repair this equipment.

NOTICE

It is the responsibility of the owner/user to install, inspect, test, maintain, and operate a trolley hoist in accordance with ANSI/ASME B30.16, "Safety Standard for Overhead Hoists", OSHA Regulations and ANSI/NFPA 70, "National Electric Code". If the trolley hoist is installed as part of a total lifting system, such as an overhead crane or monorail, it is also the responsibility of the owner/user to comply with the applicable ANSI/ASME B30 volume that addresses that type of equipment.

It is the responsibility of the owner/user to have all personnel that will install, inspect, test, maintain, and operate a trolley hoist read the contents of this manual and applicable portions of ANSI/ASME B30.16, "Safety Standard for Overhead Hoists", OSHA Regulations and ANSI/NFPA 70, "National Electric Code". If the trolley is installed as part of a total lifting system, such as an overhead crane, the applicable ANSI/ASME B30 volume that addresses that type of equipment must also be read by all personnel.

If the trolley hoist owner/user requires additional information, or if any information in the manual is not clear, contact Harrington or the distributor of the trolley. Do not install, inspect, test, maintain, or operate this trolley hoist unless this information is fully understood.

A regular schedule of inspection of the trolley hoist in accordance with the requirements of ANSI/ASME B30.16 should be established and records maintained.

1.2 Warning Tag and Labels

The warning tag illustrated below in Figure 1-1 is supplied with each RH Advantage trolley hoist shipped from the factory. If the tag is not attached to the pendant cord for your hoist/trolley, order a tag from your dealer and install it. Read and obey all warnings attached to this Trolley Hoist. Tag is not shown actual size.

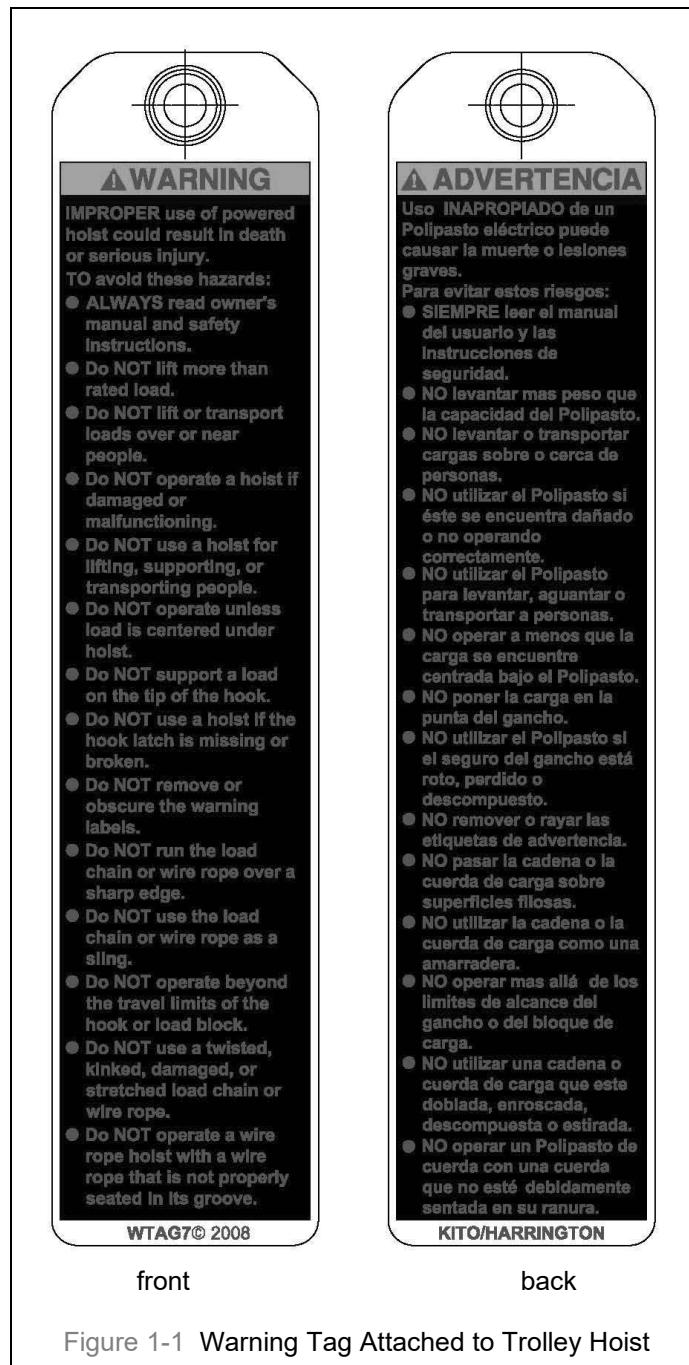

2.0 Technical Information

2.1 Specifications

2.1.1 Product Code:

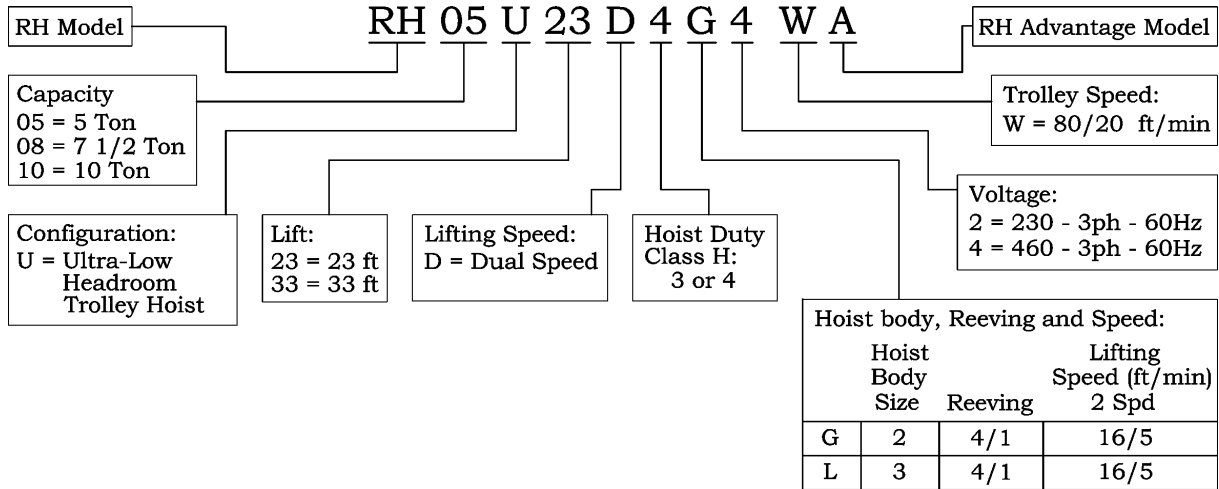

2.1.2 Hoist and Trolley Size – The RH Advantage trolley hoists are available in 2 basic sizes. These sizes are referred to throughout this manual to identify what information applies to which trolley hoist. The 10th digit in the product code designates the sizes as shown in Table 2-1 below.

10 TH Digit in Product Code	Hoist Size	Trolley Size
G	2	2
L	3	3

2.1.3 **⚠ WARNING** The 5 Ton trolley hoist and the 7 ½ Ton US trolley hoist **are not** the same trolley hoist. Although they have identical specifications in Table 2-2, they **are not** identical trolley hoists. The 7 ½ Ton trolley hoist utilizes a **higher strength** 7 ½ Ton rated wire rope and **includes** a 7 ½ Ton rated load limiter.

2.1.4 Operating Conditions and Environment

Temperature Range: +14° to +104°F (-10° to +40°C)
 Humidity: 80% or less
 Electrical Enclosure Rating: IP55
 Brake Enclosure Rating: IP23
 Supply Voltage: 230V-3ph-60Hz or 460V-3ph-60Hz
 Control Voltage: 110V-1ph-60Hz

Table 2-2 RH Advantage Trolley Hoist – Hoist Specifications									
Capacity (Tons)	Product Code	Lift (ft)	Lifting Speed (ft/min)	Reeving (parts/reeving)	Rope (mm)	Dual Speed Lifting Motor 3 Phase 60Hz			Net Weight (lbs)
						Output (Hp)	Rated Current (amps)		
			@460V				@230V		
5	RH05U23D4G-①-WA*	23	16/5	4/1	9	8.2/2.7	11.5/9.6	23.0/19.2	991
	RH05U33D4G-①-WA*	33							1101
7 ½	RH08U23D3G-①-WA	23							991
	RH08U33D3G-①-WA	33							1101
10	RH10U23D4L-①-WA	23			13	16.3/5.4	23.0/17.3	46.0/34.6	2429
	RH10U33D4L-①-WA	33							2671

① 2 = 230V – 3ph – 60Hz
4 = 460V – 3ph – 60Hz

*5 Ton rated only, do not use in 7 ½ Ton US applications

Table 2-3 RH Advantage Trolley Hoist – Trolley Specifications						
Capacity (Tons)	Product Code	Standard Flange Width B (in)	Traversing Motor			
			Output (Hp)	Dual Speed 80/20 ft/min		
				Rated Current (amps)		
@460V	@230V					
5	RH05U23D4G-①-WA	4.69 to 15.75	0.52/0.11	1.0/0.8	2.0/1.6	
	RH05U33D4G-①-WA					
7 1/2	RH08U23D3G-①-WA					
	RH08U33D3G-①-WA					
10	RH10U23D4L-①-WA	5.31 to 15.75	0.82/0.2	1.35/1.2	2.7/2.4	
	RH10U33D4L-①-WA					

2.2 Dimensions

Table 2-4 RH Advantage Trolley Hoist – Dimensions

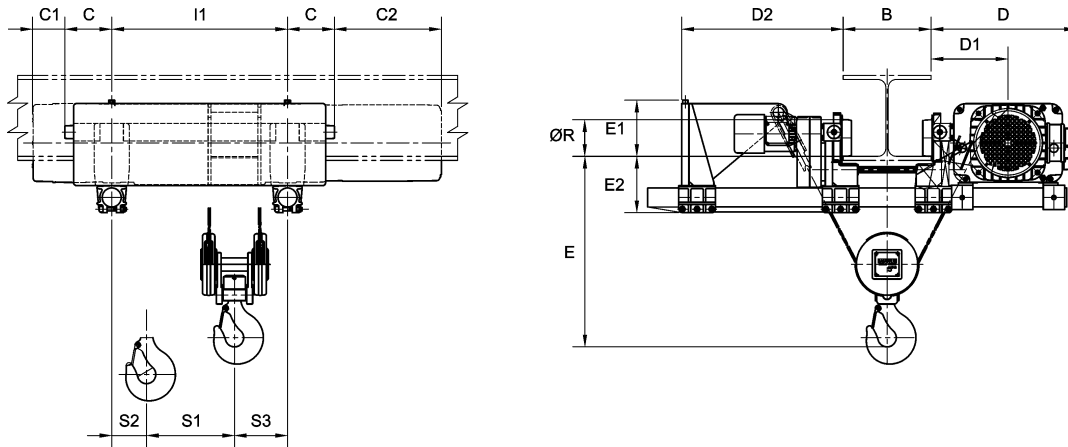

- Note:
- Ultra-Low headroom trolleys are suitable for use on S or W shaped beams.
 - Refer to Table 2-3 for flange range dimension B.
 - Refer to Table 2-5 for headroom dimension E.

Capacity (Tons)	Product Code	C (in)	C1 (in)	C2 (in)	D (in)	D1 (in)	D2 (in)	E1 (in)	E2 (in)	l1 (in)	Ø R (in)	S1 (in)	S2 (in)	S3 (in)
5	RH05U23D4G-①-WA	6.3	4.3	14.4	19.5	10.4	22.1	7.6	7.6	23.6	4.92	5.3	11.2	7.1
	RH05U33D4G-①-WA											8.3	23.2	7.9
7 1/2	RH08U23D3G-①-WA											5.3	11.2	7.1
	RH08U33D3G-①-WA											8.3	23.2	7.9
10	RH10U23D4L-①-WA	10.8	-2.8	16.9	24.6	13.2	24.5	10.7	10.2	29.1	7.87	6.3	13.4	9.4
	RH10U33D4L-①-WA									49.6		9.4	29.5	10.6

- Note:
- Ultra-Low headroom trolleys are suitable for use on S or W shaped beams.
 - Refer to page 9 for flange range B.

Table 2-5 RH Advantage Trolley Hoist – Headroom

Hoist Code	Flange Range (in)	Headroom, E* (in)	Headroom, E for 6 inch Flange (in)
G	4.69 to 6.49	18.9	18.9
	6.50 to 15.75	$10.9 + (1.23 \times T)$	
L	5.31 to 10.51	24.0	24.0
	10.52 to 15.75	$11.4 + (1.20 \times T)$	

*T in formulas is the exact beam flange width in inches.

Table 2-6 Bottom Hook – Dimensions

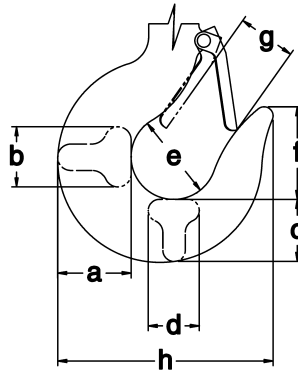

Capacity (Tons)	Product Code	a (in)	b (in)	c (in)	d (in)	e (in)	f (in)	g (in)	h (in)
5	RH05U23D4G-Ⓢ-WA	2.6	2.1	2.3	1.8	2.5	2.8	1.7	6.7
	RH05U33D4G-Ⓢ-WA								
7 1/2	RH08U23D3G-Ⓢ-WA								
	RH08U33D3G-Ⓢ-WA								
10	RH10U23D4L-Ⓢ-WA	3.5	2.8	3.0	2.4	3.1	3.5	2.0	8.9
	RH10U33D4L-Ⓢ-WA								

Table 2-7 Reaction Forces at Rated Load

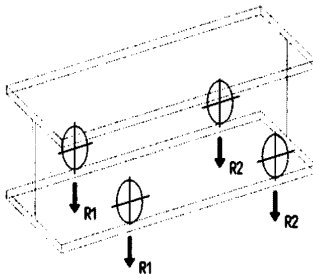

Capacity (Tons)	Ultra- Low Headroom Trolley Wheel Reaction Forces		
	Product Code	R1 (lbs)	R2 (lbs)
5	RH05U23D4G-Ⓢ-WA	3819	1660
	RH05U33D4G-Ⓢ-WA	4356	1178
7 1/2	RH08U23D3G-Ⓢ-WA	5569	2410
	RH08U33D3G-Ⓢ-WA	6356	1678
10	RH10U23D4L-Ⓢ-WA	7523	3626
	RH10U33D4L-Ⓢ-WA	8704	2566

Table 2-8 Trolley Wheel – Dimensions						
Capacity (Tons)	Product Code	a (in)	b (in)	i (in)	Wheel Dia. $\varnothing R$ (in)	Maximum Flange Thickness t (in)
5	RH05U23D4G-Ⓢ-WA	1.38	1.14	0.47	4.92	0.91
	RH05U33D4G-Ⓢ-WA					
7 ½	RH08U23D3G-Ⓢ-WA					
	RH08U33D3G-Ⓢ-WA					
10	RH10U23D4L-Ⓢ-WA	1.77	1.50	0.75	7.87	1.50
	RH10U33D4L-Ⓢ-WA					

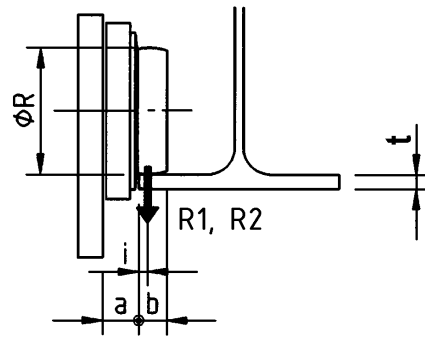

Note: See Ultra- Low Headroom Trolley Wheel Reaction Forces Table 2-7 for reaction forces R1 and R2.

3.0 Pre-operational Procedures

3.1 General Information

- 3.1.1 When the RH Advantage trolley hoist is incorporated into lifting systems utilizing other equipment, follow and complete all pre-operational procedures and instructions provided with the equipment. Special wiring considerations must also be taken to complete the integration of the RH Advantage trolley hoist into the system.
- 3.1.2 The RH Advantage trolley hoist is generally delivered pre-assembled and shrink-wrapped on a pallet or in a wooden crate (see Figure 3-1). During shipment and storage prior to installation, the trolley hoist should be kept between -4° and $+140^{\circ}\text{F}$ (-20° and $+60^{\circ}\text{C}$) and the relative humidity must not exceed 80%. The standard packaging is not watertight and rainproof.
- 3.1.3

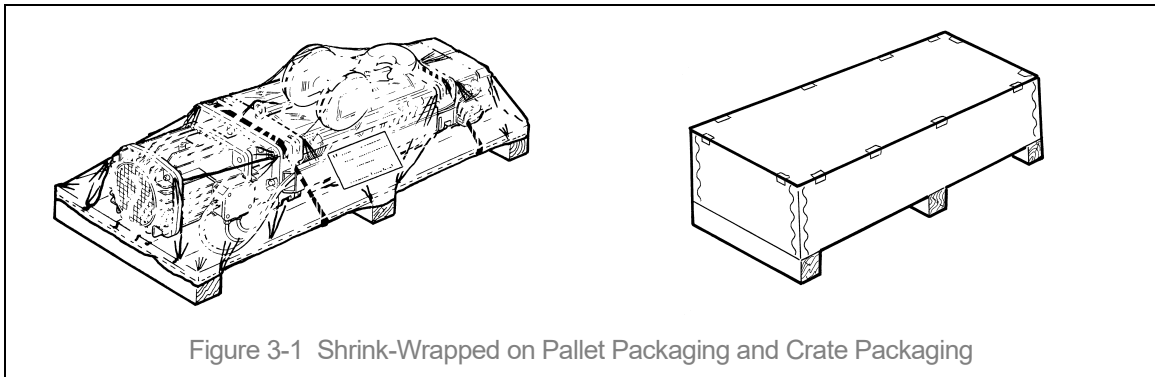

- 3.1.4 The RH Advantage trolley hoist is shipped pre-lubricated and the gear box(s) are filled with the correct amount and type of oil. Follow the lubrication requirements in Section 6.1 after the trolley hoist is placed into service.

3.2 Handling

- 3.2.1 Transportation – Move the trolley hoist utilizing a fork lift, pallet jack or hoist/crane system. Do NOT place the trolley hoist on its side (see Figure 3-2). Do NOT stack or place anything on top of the trolley hoist or crate. Avoid swinging and unbalanced conditions (see Figure 3-3).

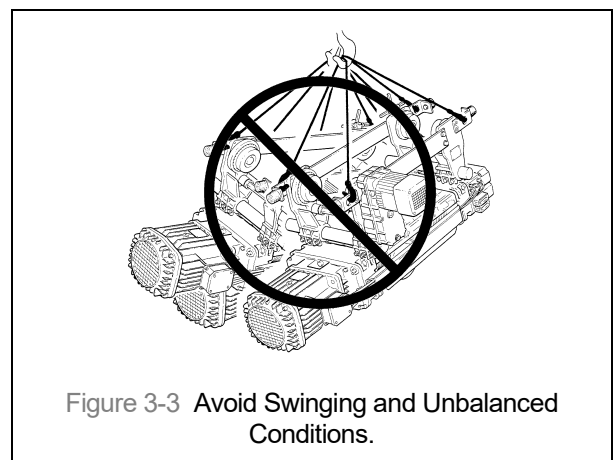
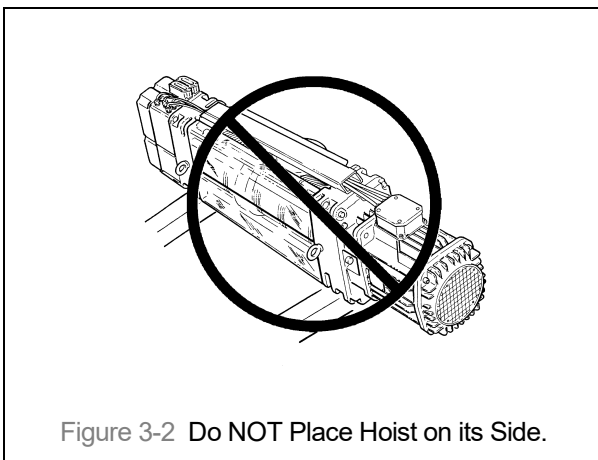

- 3.2.2 Lift points – The Advantage trolley hoists are equipped with lifting lugs to facilitate lifting the trolley hoist with a hoist or crane (see Figure 3-4). During lifting do NOT support the trolley hoist any other way.

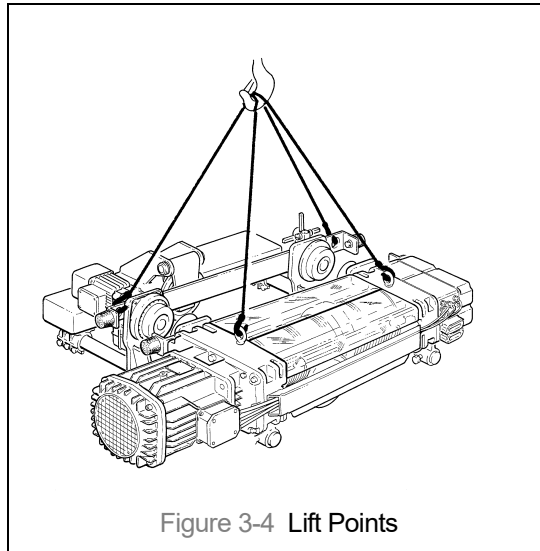

Figure 3-4 Lift Points

3.3 Mounting Location

- 3.3.1 **⚠WARNING** Prior to mounting the trolley hoist ensure that the trolley beam and its supporting structure are adequate to support the trolley hoist and its load. If necessary consult a professional that is qualified to evaluate the adequacy of the suspension location and its supporting structure.
- 3.3.2 Ensure that there is adequate vertical and horizontal clearance along the entire range of the trolley hoist's motion (see Figure 3-5).
- 3.3.3 **NOTICE** See Section 6.6 for outdoor installation considerations.

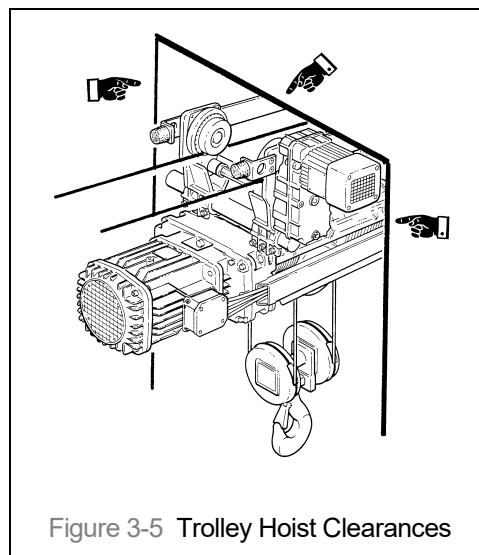

Figure 3-5 Trolley Hoist Clearances

3.4 Assembly, Adjustments and Mounting

3.4.1 RH Advantage Trolley Hoist Installation

- 1) Make sure the mounting location complies with Section 3.3.
- 2) Install any additional devices, if any (power supply cords or pendants, for instance – see Section 3.5) onto the trolley hoist. If the trolley hoist is not secured to a pallet, place and secure it to one making sure that the trolley hoist is completely stable (see Figure 3-6).
- 3) Remove the Bottom Block from the pallet/packing and place it on the ground. Use a hoist or other suitable lifting means to pickup the Bottom Block if it is heavier than 50 pounds (weight is written on the container if it exceeds 50 pounds). Always lift/hold the Bottom Block from the Hook regardless if it is lifted using a hoist or handled manually (see Figure 3-7).
- 4) On the counterweight side, loosen the Screws (D) that attach the Stiffening Plates (E) to Side Plates (F) and loosen the Lock-Nuts (G) on the Stirrups (H) that secure the Side Plates (F) to the Load Bars (J) (see Figure 3-10).
- 5) Remove the Nuts (K) and Socket Bolts (L) to remove the Spacers (M) from the Stirrups (H) so that the Side Plates (F) on the counterweight side can move freely along the Load Bars (J) (see Figure 3-11).
- 6) For relatively small beam flange widths (at the lower end of the flange range – see Table 2-3), the trolley Drive Shaft must be shortened to allow the Side Plates (F) to adjust close enough together as required. Drive the Spring Pin attaching the Drive Pinion, slide the counterweight side Side Plates (F) out and remove the Drive Shaft. After cutting the Drive Shaft, reinstall it onto the trolley and reattach the Drive Pinion.

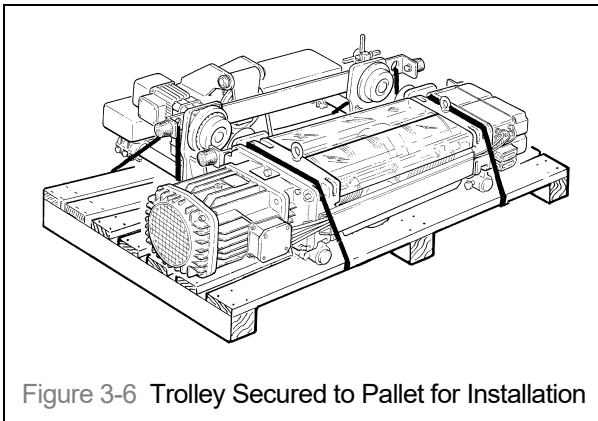

Figure 3-6 Trolley Secured to Pallet for Installation

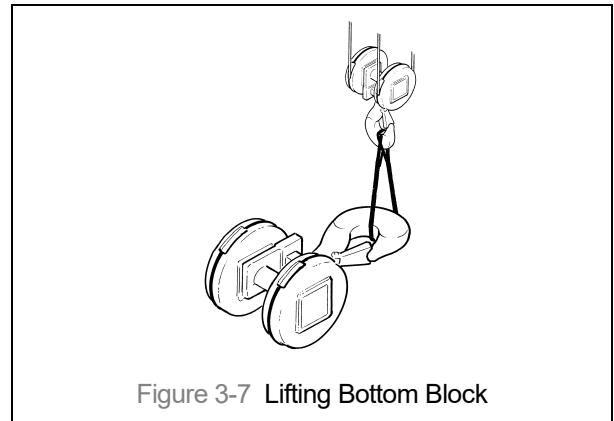

Figure 3-7 Lifting Bottom Block

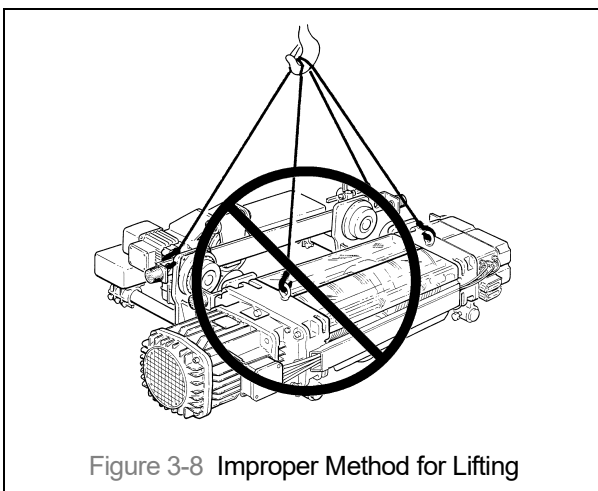

Figure 3-8 Improper Method for Lifting

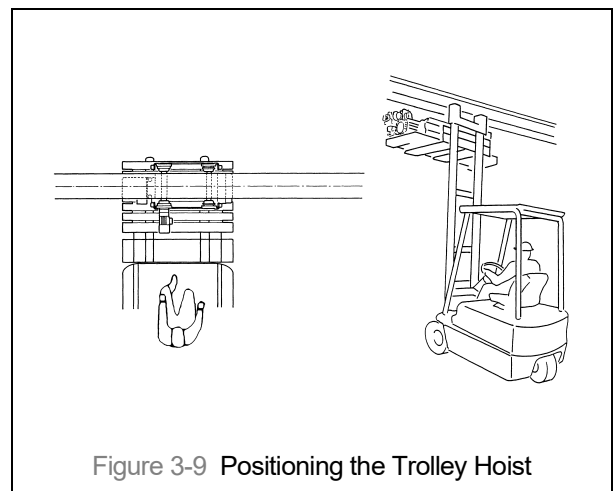
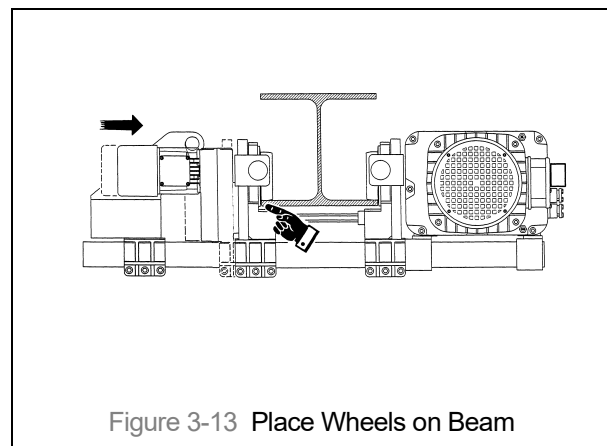
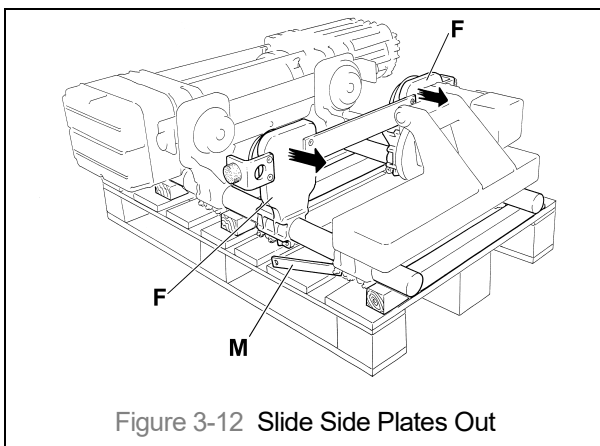
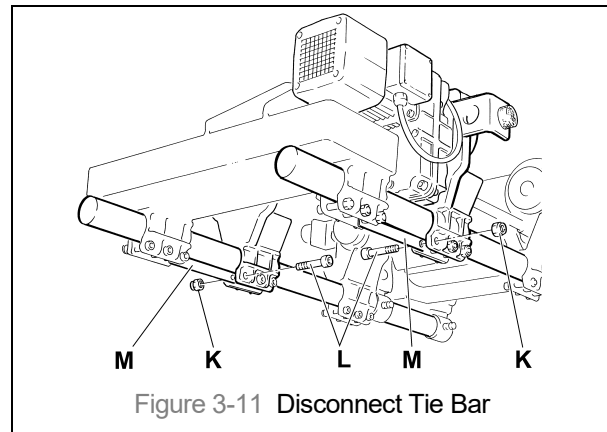
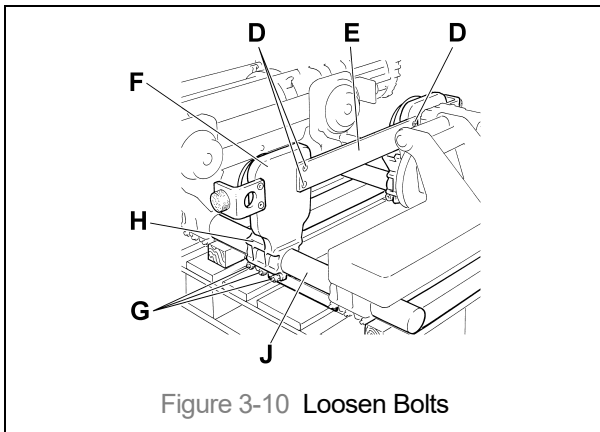

Figure 3-9 Positioning the Trolley Hoist

- 7) **⚠️ WARNING** When installing the trolley hoist on a beam, ALWAYS raise the hoist into position with the trolley assembled together and securely attached to a pallet. Raise the trolley hoist with a forklift, lifting platform, or other similar means. NEVER use slings to raise and install the trolley hoist onto the beam (see Figure 3-8).
- 8) Using a forklift or another suitable means, position the pallet so that the horizontal axis of the beam is parallel to the horizontal axis of the hoist (see Figure 3-9).
- 9) Temporarily slide the Side Plates (F) on the counterweight side along the Load Bars (J) so that the distance between the faces of the trolley wheel is wider than the beam flange (see Figure 3-12).
- 10) **⚠️ WARNING** This applies to ultra-low headroom trolleys only. When preparing the trolley for placement on the beam, ALWAYS move the Side Plates (F) on the counterweight side, DO NOT remove the Side Plates (F) on the hoist side. DO NOT remove the counterweight.
- 11) Use a movable scaffolding or a lifting platform so that one person can reach the height of the beam and guide the forklift operator. Raise the pallet slowly and carefully avoiding any swinging or oscillations until the trolley hoist reaches the bottom flange beam.
- 12) Guiding the fork lift operator, slowly raise the pallet while keeping it level until the running surface of the trolley wheels are above the bottom flange of the beam. Then move the pallet horizontally until the trolley wheels on the hoist side are over the bottom flange.
- 13) From the scaffolding or lifting platform, slide the previously moved Side Plates (F) along the Load Bars (J) until the trolley wheels are over the beam flange and the trolley wheel flanges of the Side Plates (F) on the counterweight side are very close to the edge of the beam flange (see Figure 3-13).



- 14) Lower the pallet just enough until the trolley wheels are resting on the beam flange.
- 15) Check that all 4 trolley wheels rest correctly on the beam and that the clearance between the wheel edge and the edge of the beam is 5/64 inch (2 mm) maximum at all 4 wheels (see Figure 3-14).
- 16) Remove the straps/ropes securing the trolley hoist to the pallet and lower the pallet to the ground.
- 17) Reattach the Spacers (M) to the Stirrups (F).
- 18) Using a torque wrench, fully tighten the Screws (D) attaching the Stiffening Plates (E) and the Locking Nuts (G) of Stirrups (H) to the specified torque values shown in the Table 3-1.

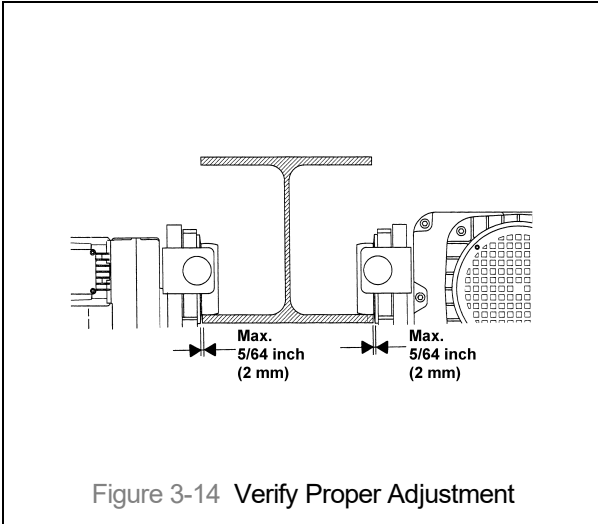

Table 3-1 Torque Values

	Torque Value (ft-lbs)	
	2	3
Trolley Size	2	3
Load Bar Lock-Nuts (G)	62	150
Stiffener Screws (D)	18	49

3.5 Electrical Connections

3.5.1 **⚠ CAUTION** Ensure that the voltage of the electric power supply is proper for the trolley hoist.

3.5.2 **⚠ CAUTION** Do NOT apply electronic soft-start control or voltage varying controls to the RH Advantage's lifting or traversing motors. Use of such devices may cause the motor brake and other electrical components to malfunction. For variable frequency drives contact Harrington for more information.

3.5.3 **⚠ DANGER** Before proceeding, ensure that the electrical supply for the hoist or trolley has been de-energized (disconnected). Lock out and tag out in accordance with ANSI Z244.1 "Personnel Protection -Lockout/Tagout of Energy Sources".

3.5.4 Installing Power Supply Cord

- 1) Refer to Figure 3-15 and the wiring diagram provided with the Hoist.
- 2) Remove Control Cover (A).
- 3) Loosen the Cable Fitting (C) located on the left side of the electrical enclosure and insert the power supply cord. Pull through enough cord to reach the Power Supply Terminal (D) then securely tighten the Cable Fitting (C).
- 4) Connect the 3 phase power leads (L1, L2 and L3) and the ground lead of the Power Supply Cord to the Power Supply Terminal. Make sure the terminals are securely tightened and each lead is completely isolated.
- 5) Replace the Control Cover (A). Be careful to not damage the seal or sealing surfaces and make sure to securely tighten all fasteners or latches.

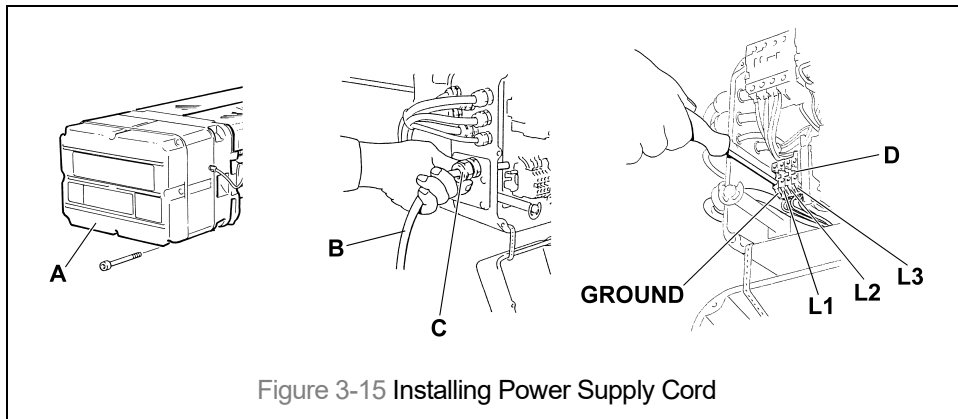

3.5.5 Installing Pendant

- 1) Refer to Figure 3-16, the wiring diagram and the interconnection diagram provided with the Hoist.
- 2) Remove Control Cover (A).
- 3) Access to Terminal Strip: For hoists with the integral electrical enclosures (plastic cover), the Terminal Strips are located on the back side of the Panel (F). Gain access by removing the Socket Bolts (E) securing the Panel (F), loosening the Set Bolts (G) on the Support Bars (H), then slide and rotate the Panel (F) forward.
- 4) Loosen the Cable Fitting (C) located on the left side of the electrical enclosure and insert the pendant cord. Pull through enough cord to reach the terminals then securely tighten the Cable Fitting (C).
- 5) Attach a strain relief cable or chain between the pendant and hoist. The cord or chain should attach to the Small plate or eyebolt located at the bottom of the electrical enclosure.
- 6) Connect the individual pendant leads to the correct terminals as shown on the interconnection diagram. Make sure the terminals are securely tightened and each lead is completely isolated.
- 7) Reattach the Control Panel (F) and replace the Control Cover (A) or close the metal electrical enclosure. Be careful to not damage the seal or sealing surfaces and make sure to securely tighten all fasteners or latches.

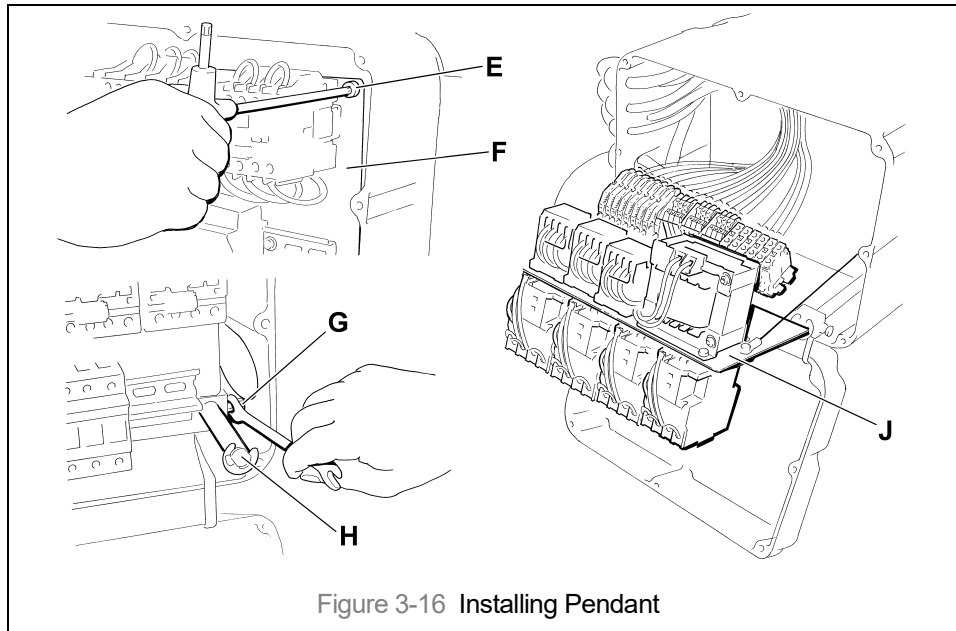

Figure 3-16 Installing Pendant

- 3.5.6 Connection to Electrical Power Source - The 3 power leads of the Power Supply Cable (normally red, white, and black wires) should be connected to an Electric Power Disconnect Switch or Circuit Breaker. This connection should be made so that the hoist is phased properly. Refer to Section 3.7.4 for instructions on how to check for correct power supply phase connection.
- 3.5.7 Fuse/Breaker Capacity - The trolley and hoist's power supply should be equipped with overcurrent protection such as fuses, which should be selected for 110% to 120% of total listed full load amperage, and should be dual element time-delay fuses. For the total full load amperage draw, add the amperage draws shown on the motor nameplates of ALL lifting and traversing motors.
- 3.5.8 **⚠ DANGER** Grounding - An improper or insufficient ground connection creates an electrical shock hazard when touching any part of the hoist or trolley. In the Power Supply Cable the ground wire will be either Green with Yellow stripe or solid Green. It should always be connected to a suitable ground connection. Do not paint the trolley wheel running surfaces of the beam as this can affect grounding.

3.6 Reeving and Adjustments

3.6.1 Reeving the bottom hook

- 1) Working from a scaffold or lifting platform, remove the Retaining Ring (B) and Load Limiter Pin (D) from the Terminal Head Crossbar (A). Let the Load Limiter (C) rotate downward and remove the Terminal Head (F) from the Lever Support/Load Limiter Assembly (C) by pulling out the Terminal Head Pin (E). (see Figure 3-17). **Note:** the Load limiter is standard on the 7½T, optional on the 5T and 10T trolley hoists.
- 2) From the ground, press the down button on the pendant until there is sufficient rope unwound to reeve the hoist. Take care not to activate the down limit switch.
- 3) Place the Bottom Block on the ground so that it is positioned perpendicular to the hoist, and insert the rope end into the bottom block as shown in Figure 3-18 for 4/1 reeved hoists (4 rope-falls). To make rope insertion easier, temporarily attach a wire to the end of the rope with adhesive tape and use the wire to pull the rope through the Bottom Block. Securely tie a string or cord to the end of the rope and pull the wire rope up to the hoist from the scaffolding/platform. Thread the rope through the return pulley installed in the hoist, then back through the Bottom Block (see Figure 3-18).
- 4) Insert the end of the rope into the Terminal Head (F) and making sure at least 4 inches of rope extend beyond the Terminal Head (F). Install the Wedge (G) into the Terminal Head (F) and pull the rope until the Wedge (G) and the rope are tightly seated in the Terminal Head (F) (Figure 3-19).
- 5) **⚠ WARNING** Make certain the wire rope is tight against the Wedge (G) in the Terminal Head (F).
- 6) Attach the Rope Clamp (H) 2 inches from the Terminal Head (F) and fully tighten the nuts. Do NOT clamp the free end of the rope to the load bearing rope fall (the rope between the Terminal Head (F) and the Bottom Block) (Figure 3-20).
- 7) Reattach the Terminal Head (F) to the Load Limiter (C) with the Terminal Head Pin (E) and reattach the Load Limiter (C) to the Terminal Head Crossbar (A) using the Load Limiter Pin (D) and Retaining ring (B) (Figure 3-21). **Note:** the Load limiter is standard on the 7½T, optional on the 5T and 10T trolley hoists.

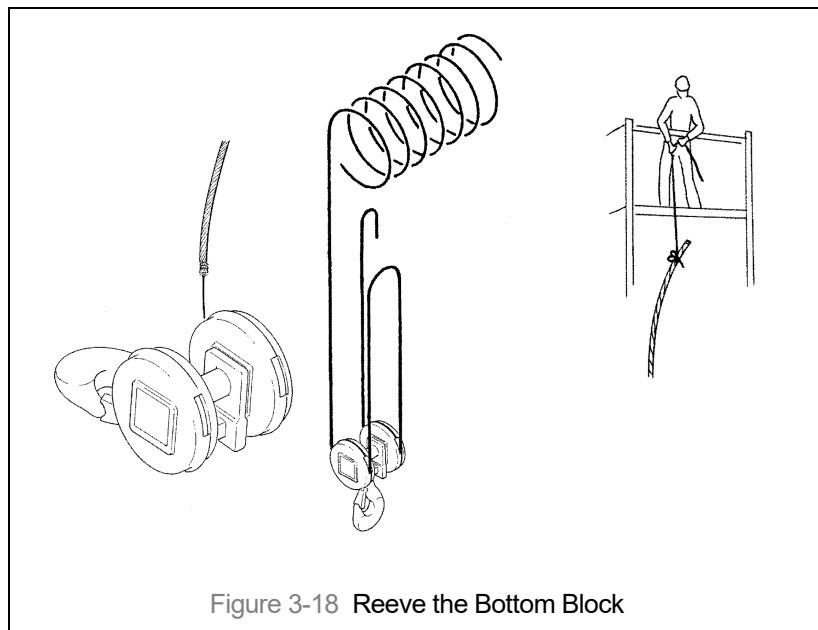
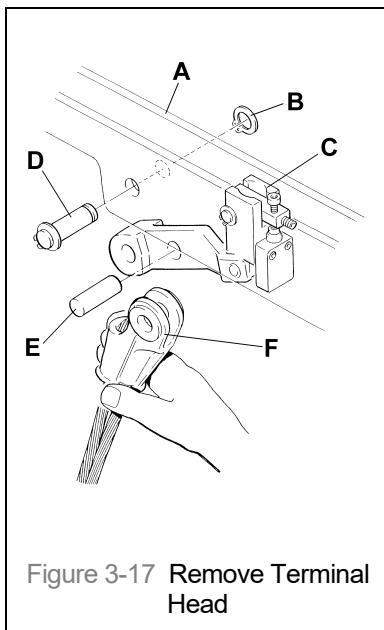

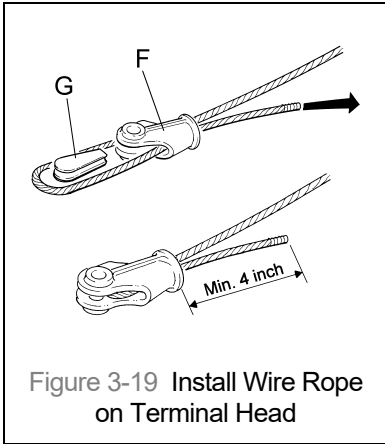

Figure 3-19 Install Wire Rope on Terminal Head

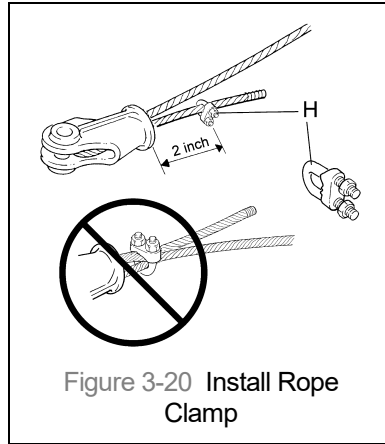

Figure 3-20 Install Rope Clamp

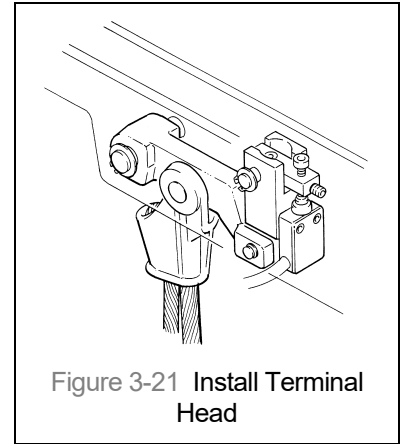
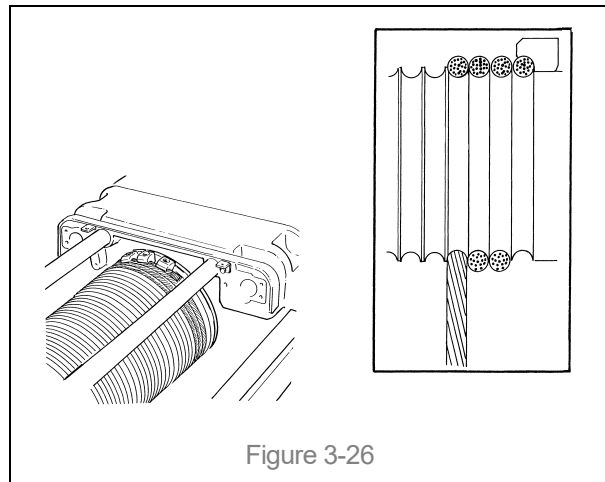
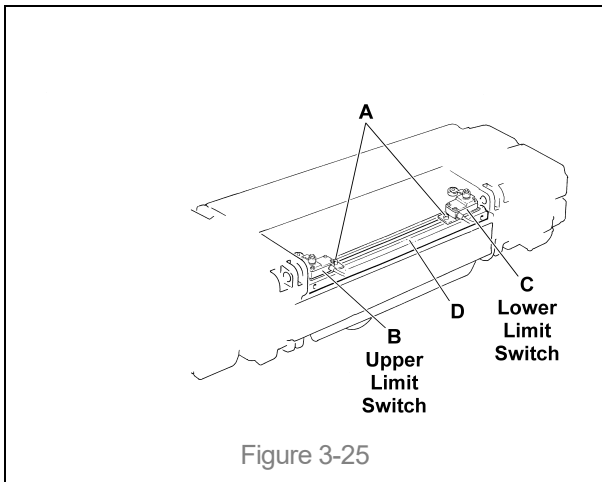
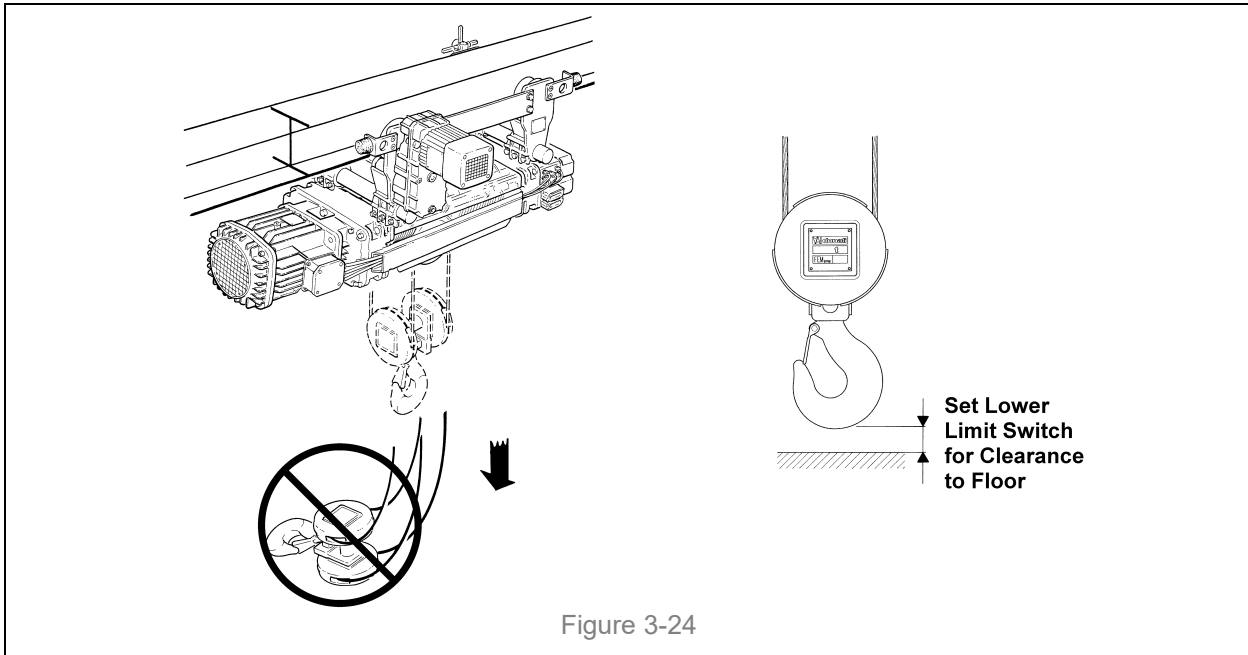
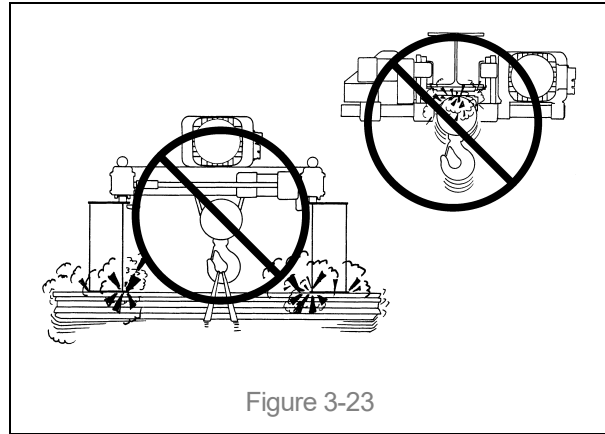
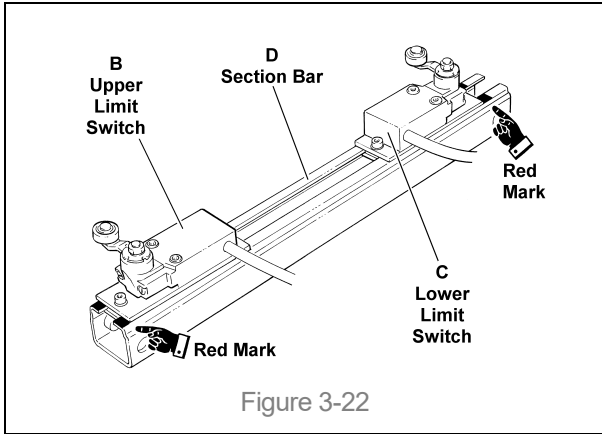

Figure 3-21 Install Terminal Head

3.6.2 Adjusting the Limit Switches:

- 1) **⚠ WARNING** The maximum upper and lower Limit Switch (B, C) adjustments are marked in red on the Section Bar (D). NEVER adjust the limit switches past the red marks (Figure 3-22).
- 2) **⚠ WARNING** The upper Limit Switch (B) MUST be adjusted to prevent the collision of the load and/or Bottom Block with any part of the hoist, structure or girder(s) (Figure 3-23).
- 3) **⚠ WARNING** NEVER adjust the upper Limit Switch (B) so that the Bottom Block can rise above the position dictated by dimension "E" in Table 2-5.
- 4) **⚠ WARNING** The adjustment of the lower Limit Switch (C) MUST always ensure a minimum of 3 turns of wire rope completely wound on the drum (Figure 3-26).
- 5) The lower Limit Switch (C) MUST be adjusted so that the hook can be lowered fully for the application, WITHOUT the Hook/Bottom Block resting on the floor causing a slack condition in the wire ropes (Figure 3-24).
- 6) Lower Limit Switch (C) Setting:
 - + Press the down button on the pendant and carefully lower the Hook to the position of maximum descent for the application.
 - + Loosen the screws (A) so that the lower Limit Switch (C) can freely run along the Section Bar (D) then position the Switch so that it engages the striker on the rope guide. Secure the Switch in position by tightening the Screws (A) (Figure 3-25).
 - + Carefully verify the correct activation of the lower Limit Switch (C) by lowering the Hook several times and readjust the Lower Limit Switch (C) as necessary.
- 7) Upper Limit Switch (B) Setting:
 - + Carefully raise the Hook until it is at the uppermost position dictated by dimension "E" in Table 2-5.
 - + If the upper Limit Switch activates before the Hook reaches the uppermost position, measure how far the Hook still needs to travel, then multiply the distance by 4. Adjust (increase) the length of rope that extends beyond the Terminal Head by the resulting amount (Refer to Section 3.6.1).
 - + Loosen the screws (A) so that the upper Limit Switch (B) can freely run along the Section Bar (D) then position the Switch so that it engages the striker on the rope guide. Secure the Switch in position by tightening the Screws (A) (Figure 3-25).
 - + Carefully verify the correct activation of the upper Limit Switch (B) by raising the Hook several times and readjust the Upper Limit Switch (B) as necessary.

- 8) Check, according to the foreseen configuration, that the height of approach of the hook going up is not less than that stated in Table 2-5 (dimension "H").



3.7 Pre-operational Checks and Trial Operation

- 3.7.1 Refer to the trolley hoist's nameplate and record the Product Code, and Serial Numbers in the space provided on the cover of this manual.
- 3.7.2 Perform pre-operational checks for the trolley hoist:
- **⚠ WARNING** Confirm the adequacy of the rated capacity for all slings, chains, wire ropes and all other lifting attachments before use. Inspect all load suspension members for damage prior to use and replace or repair all damaged parts.
 - **⚠ WARNING** Verify and correct all wire rope irregularities prior to operating the hoist. Refer to Section 3.6.
 - Measure and record the "k" dimension of the bottom hook on the hoist. See Table 5-5 under Section 5.
 - Ensure that trolley is properly installed on the beam, and stops for the trolley are correctly positioned and securely installed on the beam.
 - Ensure that all nuts, bolts and split pins (cotter pins) are sufficiently fastened.
 - Pull down on the Pendant and ensure that the Cord Strain Relief Cable takes the force, not the Pendant Cord.
 - **⚠ CAUTION** Check supply voltage before everyday use. If the voltage varies more than 10% of the rated value, electrical devices may not function normally.
- 3.7.3 Confirm proper operation:
- Before operating read and become familiar with Section 4 – Operation.
 - Before operating ensure that the hoist (and trolley) meets the Inspection, Testing and Maintenance requirements of ANSI/ASME B30.16.
 - Before operating ensure that nothing will interfere with the full range of the hoist's (and trolley's) operation.
- 3.7.4 Proceed with trial operation to confirm proper operation.
- Verify that the controls agree with hoist direction. Make sure that depression of the Up button lifts the Bottom Block and depression of the Down button lowers the Bottom Block. If the Bottom Block does not move in the correct direction when the push buttons are pushed, the power supply is phased incorrectly. In this case, turn off the power source or breaker switch then reverse any two of the three wires at the power source. The hook will then move in accordance with the directions of the push button.
 - Operate the trolley through its full range of motion. Make sure the trolley runs smoothly and does not bind. Check the power supply and festoon system for proper operation
 - Perform inspections per Section 5.3, "Frequent Inspections".

4.0 Operation

4.1 Introduction

DANGER

DO **NOT** WALK UNDER A SUSPENDED LOAD

WARNING

HOIST OPERATORS SHALL BE REQUIRED TO READ THE OPERATION SECTION OF THIS MANUAL; THE WARNINGS CONTAINED IN THIS MANUAL, INSTRUCTION AND WARNING LABELS ON THE HOIST OR LIFTING SYSTEM, AND THE OPERATION SECTIONS OF ANSI/ASME B30.16 and ANSI/ASME B30.10. THE OPERATOR SHALL ALSO BE REQUIRED TO BE FAMILIAR WITH THE HOIST AND HOIST CONTROLS BEFORE BEING AUTHORIZED TO OPERATE THE HOIST OR LIFTING SYSTEM.

HOIST OPERATORS SHOULD BE TRAINED IN PROPER RIGGING PROCEDURES FOR THE ATTACHMENT OF LOADS TO THE HOIST HOOK.

HOIST OPERATORS SHOULD BE TRAINED TO BE AWARE OF POTENTIAL MALFUNCTIONS OF THE EQUIPMENT THAT REQUIRE ADJUSTMENT OR REPAIR, AND TO BE INSTRUCTED TO STOP OPERATION IF SUCH MALFUNCTIONS OCCUR, AND TO IMMEDIATELY ADVISE THEIR SUPERVISOR SO CORRECTIVE ACTION CAN BE TAKEN.

HOIST OPERATORS SHOULD HAVE NORMAL DEPTH PERCEPTION, FIELD OF VISION, REACTION TIME, MANUAL DEXTERITY, AND COORDINATION.

HOIST OPERATORS SHOULD **NOT** HAVE A HISTORY OF OR BE PRONE TO SEIZURES, LOSS OF PHYSICAL CONTROL, PHYSICAL DEFECTS, OR EMOTIONAL INSTABILITY THAT COULD RESULT IN ACTIONS OF THE OPERATOR BEING A HAZARD TO THE OPERATOR OR TO OTHERS.

HOIST OPERATORS SHOULD **NOT** OPERATE A HOIST OR LIFTING SYSTEM WHEN UNDER THE INFLUENCE OF ALCOHOL, DRUGS, OR MEDICATION.

OVERHEAD HOISTS ARE INTENDED ONLY FOR VERTICAL LIFTING SERVICE OF FREELY SUSPENDED UNGUIDED LOADS. DO **NOT** USE HOIST FOR LOADS THAT ARE NOT LIFTED VERTICALLY, LOADS THAT ARE NOT FREELY SUSPENDED, OR LOADS THAT ARE GUIDED.

NOTICE

- Read ANSI/ASME B30.16 and ANSI/ASME B30.10.
- Read the hoist manufacturer's Operating and Maintenance Instructions.
- Read all labels attached to equipment.

The operation of an overhead hoist involves more than activating the hoist's controls. Per the ANSI/ASME B30 standards, the use of an overhead hoist is subject to certain hazards that cannot be mitigated by engineered features, but only by the exercise of intelligence, care, common sense, and experience in anticipating the effects and results of activating the hoist's controls. Use this guidance in conjunction with other warnings, cautions, and notices in this manual to govern the operation and use of your overhead hoist.

4.2 Shall's and Shall Not's for Operation

WARNING

Improper operation of a hoist can create a potentially hazardous situation that, if not avoided, could result in death or serious injury, and substantial property damage. To avoid such a potentially hazardous situation **THE OPERATOR SHALL:**

- **NOT** operate a damaged, malfunctioning or unusually performing hoist.
- **NOT** operate a hoist until you have thoroughly read and understood Manufacturer's Operating and Maintenance Instructions or Manuals.
- Be familiar with operating controls, procedures, and warnings.
- **NOT** operate a hoist that has been modified without the manufacturer's approval or without certification that it is in conformity with ANSI/ASME B30 volumes.
- **NOT** lift more than rated load for the hoist.
- **NOT** use hoist with twisted, kinked, damaged, or worn wire rope.
- **NOT** use the hoist to lift, support, or transport people.
- **NOT** lift loads over people.
- **NOT** operate a hoist unless all persons are and remain clear of the supported load.
- **NOT** operate unless load is centered under hoist.
- **NOT** attempt to lengthen the load wire rope or repair damaged load wire rope.
- Protect the hoist's load wire rope from weld splatter or other damaging contaminants.
- **NOT** operate hoist when it is restricted from forming a straight line from hook to support in the direction of loading.
- **NOT** use load wire rope as a sling or wrap load wire rope around load.
- **NOT** apply the load to the tip of the hook or to the hook latch.
- **NOT** apply load unless the wire rope is properly seated in its grooves.
- **NOT** apply load if bearing prevents equal loading on all load-supporting ropes.
- **NOT** operate beyond the limits of the load wire rope travel.
- **NOT** leave load supported by the hoist unattended unless specific precautions have been taken.
- **NOT** allow the load wire rope or hook to be used as an electrical or welding ground.
- **NOT** allow the load wire rope or hook to be touched by a live welding electrode.
- **NOT** remove or obscure the warnings on the hoist.
- **NOT** operate a hoist on which the safety placards or decals are missing or illegible
- **NOT** operate a hoist unless it has been securely attached to a suitable support.
- **NOT** operate a hoist unless load slings or other approved single attachments are properly sized, and seated in the hook saddle.
- **NOT** use the hoist in such a way that could result in shock or impact loads being applied to the hoist.
- Take up slack carefully – make sure load is balanced and load-holding action is secure before continuing.
- Shut down a hoist that malfunctions or performs unusually and report such malfunction.
- Make sure hoist limit switches function properly.
- Warn personnel before lifting or moving a load.
- Warn personnel of an approaching load.

CAUTION

Improper operation of a hoist can create a potentially hazardous situation that, if not avoided, could result in minor or moderate injury, or property damage. To avoid such a potentially hazardous situation **THE OPERATOR SHALL:**

- Maintain a firm footing or be otherwise secured when operating the hoist.
- Check brake function by tensioning the hoist prior to each lift operation.
- Use hook latches. Latches are to retain slings, chains, etc. under slack conditions only.
- Make sure the hook latches are closed and not supporting any parts of the load.
- Make sure the load is free to move and will clear all obstructions.
- Avoid swinging the load or hook.
- Make sure hook travel is in the same direction as shown on controls.
- Inspect the hoist regularly, replace damaged or worn parts, and keep appropriate records of maintenance.
- Use the hoist manufacturer's recommended parts when repairing the unit.
- Lubricate load wire rope per hoist manufacturer's recommendations.
- **NOT** use the hoist load limiting or warning device to measure load.
- **NOT** use limit switches as routine operating stops. They are emergency devices only.
- **NOT** allow your attention to be diverted from operating the hoist.
- **NOT** allow the hoist to be subjected to sharp contact with other hoists, structures, or objects through misuse.
- **NOT** adjust or repair the hoist unless qualified to perform such adjustments or repairs.

4.3 Hoist and Trolley Controls

- 4.2.1 Dual Speed Pendant Control – Pendant controls supplied with dual speed trolley hoists have two-step control buttons. For low speed depress the button to the first step and for high speed depress the button fully to the second step. Use the Up button to raise the hoist's hook or the Down button to lower the hoist's hook as shown in Figure 4-1. Depress the Forward and Reverse buttons to move the trolley horizontally. To stop motion release the buttons.

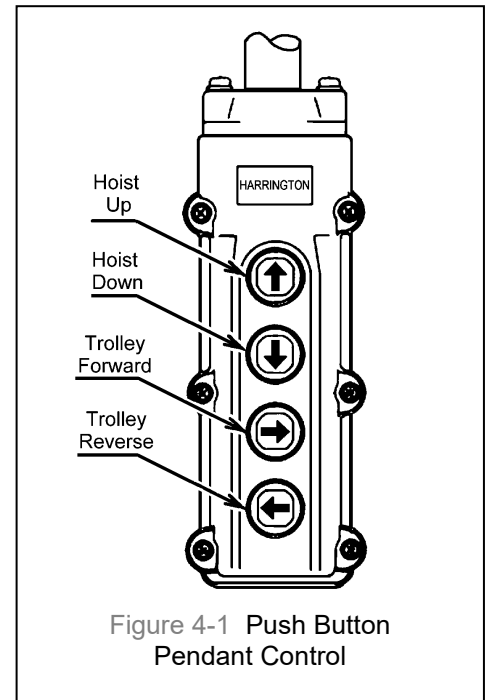

5.0 Inspection

5.1 General

- 5.1.1 The inspection procedure herein is based on ANSI/ASME B30.16. The following definitions are from ANSI/ASME B30.16 and pertain to the inspection procedure below.
- + Designated Person – a person selected or assigned by the employer or employer’s representative as being competent to perform the specific duties.
 - + Qualified Person – a person who, by possession of a recognized degree in an applicable field, or certificate of professional standing, or who, by extensive knowledge, training, and experience, has successfully demonstrated the ability to solve or resolve problems relating to the subject matter and work.
 - + Normal Service – that distributed service, which involves operation with randomly, distributed loads within the rated load limit, or uniform loads less than 65% of rated load for not more than 25% of the time.
 - + Heavy Service – that service, which involves operation within the rated, load limit that exceeds normal service.
 - + Severe Service – that service which involves normal or heavy service with abnormal operating conditions.

5.2 Inspection Classification

- 5.2.1 The Initial Inspection – a designated person shall inspect prior to initial use all new, re-installed, altered, or modified hoists/trolleys to ensure compliance with the applicable provisions of this manual.
- 5.2.2 Inspection Classification – the inspection procedure for hoists/trolleys in regular service is divided into two general classifications based upon the intervals at which inspection should be performed. The intervals in turn are dependent upon the nature of the critical components of the hoists/trolleys and the degree of their exposure to wear, deterioration, or malfunction. The two general classifications are herein designated as FREQUENT and PERIODIC, with respective intervals between inspections as defined below.
- 5.2.3 FREQUENT Inspection – visual examinations by the operator or other designated personnel with intervals per the following criteria:

Service	Hoist and Trolley Interval	Rope Inspection Interval
Normal Service	Monthly	Start of Every Shift
Heavy Service	Weekly to Monthly	
Severe Service	Daily to Weekly	
Special or Infrequent Service	As recommended by a qualified person before and after each occurrence.	

5.2.4 PERIODIC Inspection – visual inspection by a designated person with intervals per the following criteria:

Table 5-2 Periodic Inspection Intervals		
Service	Hoist and Trolley Interval	Rope Inspection Interval
Normal Service	Monthly	1) At Least monthly (per OSHA), AND 2) Determined by a qualified person and based on such factors as expected rope life as determined by experience on the particular or similar installations; severity of environment; percentage of capacity lifts; frequency rates of operation; and exposure to shock loads. Inspections need not be at equal calendar intervals and should be more frequent as the rope approaches the end of its useful life. (per ANSI B30.16-2.4.1)
Heavy Service	Weekly to Monthly	
Severe Service	Daily to Weekly	
Special or Infrequent Service	As recommended by a qualified person before the first such occurrence and as directed by the qualified person for any subsequent occurrences.	

5.3 Frequent Inspection

5.3.1 Inspections should be made on a FREQUENT basis in accordance with Table 5-3, “Frequent Inspection.” Included in these FREQUENT Inspections are observations made during operation for any defects or damage that might appear between Periodic Inspections. A designated person shall evaluate and resolve the results of FREQUENT Inspections such that the hoist/trolley is maintained in safe working condition.

Table 5-3 Frequent Inspection
All functional operating mechanisms for maladjustment and unusual sounds.
Hoist and trolley in accordance with ANSI/ASME B30.16
Operation of all limit switches and associated components
Upper limit devices in accordance with ANSI/ASME B30.16
Hoist/trolley braking system for proper operation
Hooks and hook latches in accordance with ANSI/ASME B30.10
Hook latch operation
Wire rope in accordance with Section 5.7
Wire rope reeving for compliance with Section 3.6 and 6.4
Proper function of pendant controls.

5.4 Periodic Inspection

- 5.4.1 Inspections should be made on a PERIODIC basis in accordance with Table 5-4, "Periodic Inspection." A designated person shall make evaluation and resolution of the results of PERIODIC Inspections such that the hoist is maintained in safe working condition.
- 5.4.2 For inspections where load suspension parts of the hoist/trolley are disassembled, a load test per ANSI/ASME B30.16 must be performed on the hoist/trolley after it is re-assembled and prior to its return to service.

Table 5-4 Periodic Inspection
Requirements of frequent inspection.
Evidence of loose bolts, nuts, or rivets.
Evidence of worn, corroded, cracked, or distorted parts such as suspension bolts, mounting eye bolts, stirrup bolts, stiffening plate bolts, gears, pins, bearings, pins, rollers.
Evidence of worn or damaged hook block, hook, clevises, yokes, shafts, wire rope and wire rope attachments.
Evidence of damage to hook retaining nuts or collars and pins, and welds or rivets used to secure the retaining members.
Evidence of worn or damaged rope-drum, rope guide and pulleys (sheaves).
End connections of wire rope.
Evidence of damage or excessive wear of load and idler sheaves.
Evidence of excessive wear on hoist or trolley brake system parts.
Evidence of excessive wear or damage to trolley wheels, gears and guide rollers.
Evidence of damage to supporting structure or trolley, if used.
Evidence of stress cracks on trolley stirrup plate welds.
Electrical apparatus for signs of pitting or any deterioration of visible controller contacts and electrical components, such as, switches, contacts and pushbuttons.
Proper function of motion limit devices that interrupt power or cause a warning to be activated.
Proper function of load limiter device.
Evidence of damage to all cables, including festooned cables.
Function labels on pendant control stations for legibility.
Function, instruction and warning labels properly attached to the hoist/trolley and legible (see Section 1.2).
Verify proper lubrication of gears, rope drum, rope guide, rope, sheaves and all other parts requiring lubrication.

5.5 Occasionally Used Hoists and Trolleys

- 5.5.1 Hoists that are used infrequently shall be inspected as follows prior to placing in service:
- + Hoist Idle More Than 1 Month, Less Than 1 Year: Inspect per FREQUENT Inspection criteria in Section 5.3.
 - + Hoist Idle More Than 1 Year: Inspect per PERIODIC Inspection criteria in Section 5.4.

5.6 Inspection Records

- 5.6.1 Dated inspection reports and records should be maintained at time intervals corresponding to those that apply for the hoist's PERIODIC interval per Section 5.2.4. These records should be stored where they are available to personnel involved with the inspection, maintenance, or operation of the hoist/trolley.
- 5.6.2 A long-range rope inspection program should be established and should include records of examination of ropes removed from service so a relationship can be established between visual observation and actual condition of the rope.

5.7 Inspection Methods and Criteria

- 5.7.1 This section covers the inspection of specific items. The list of items in this section is based on those listed in ANSI/ASME B30.16 for the Frequent and Periodic Inspection. In accordance with ANSI/ASME B30.16, these inspections are not intended to involve disassembly of the hoist. Rather, disassembly for further inspection would be required if frequent or periodic inspection results so indicate. Only a qualified person trained in the disassembly and re-assembly of the hoist or trolley should perform such disassembly and further inspection.

Item	Method	Criteria	Action
Functional operating mechanisms.	Visual, Auditory	Mechanisms should be properly adjusted and should not produce unusual sounds when operated.	Repair or replace as required.
Limit Switch	Function	Proper operation. Actuation of limit switch should stop hoist.	Repair or replace as required.
Hoist Braking System Operation	Function	Braking distance with rated capacity should not exceed the maximum braking distances listed in Table 5-8 .	Adjust or replace as required (see Section 6.2).
Hook – Surface Condition	Visual	Should be free of significant rust; weld splatter, deep nicks, or gouges.	Replace.
Hook – Fretting wear	Measure	The “u” and “t” dimensions should not be less than discard value listed in Table 5-6	Replace.
Hook – Stretch	Measure	The “g1” dimension should not be greater than 1.1 times that measured and recorded at the time of purchase (See Section 3.7). If recorded “g1” values are not available for hooks when new, use nominal “g1” values from Table 5-6 .	Replace.
Hook – Bent Shank or Neck	Visual	Shank and neck portions of hook should be free of deformations.	Replace.
Hook Block Assembly	Visual	Should be free of significant rust; weld splatter, nicks, gouges. Holes should not be elongated, fasteners should not be loose, and there should be no gap between mating parts.	Tighten or replace as required.
Hook Block – Swivel Bearing	Visual, Function	Bearing parts and surfaces should not show significant wear, and should be free of dirt, grime and deformations. Hook should rotate freely with no roughness.	Clean/lubricate, or replace as required.

Table 5-5 Hoist (and Trolley) Inspection Methods and Criteria (continued)

Item	Method	Criteria	Action
Hook Block – Sheave(s) and Shaft	Visual, Function	Sheave(s) should be free of significant wear. Sheave surfaces should be free of nicks, gouges, dirt and grime. Bearing parts and surfaces of Sheave and Shaft should not show significant wear. Sheave should rotate freely with no roughness or significant free play.	Clean/lubricate, or replace as required.
Hook – Hook Latches	Visual, Function	Latch should not be deformed. Attachment of latch to hook should not be loose. Latch spring should not be missing and should not be weak. Latch movement should not be stiff – when depressed and released latch should snap smartly to its closed position.	Replace.
Hoist – Housing and Mechanical Components	Visual, Auditory, Vibration, Function	Hoist components including load blocks, suspension housing, wire rope attachments, clevises, yokes, suspension bolts, shafts, gears, bearings, pins and rollers should be free of cracks, distortion, significant wear and corrosion. Evidence of same can be detected visually or via detection of unusual sounds or vibration during operation.	Replace
Trolley – Housing and Mechanical Components	Visual, Auditory, Vibration, Function	Trolley components including load bars, trolley wheels, trolley wheel axles, eye bolts, hex shafts, gears, bearings, pins, rollers, and bumpers should be free of cracks, distortion, significant wear, and corrosion. Evidence of same can be detected visually or via detection of unusual sounds or vibration during operation.	Replace.
Bolts, Nuts and Rivets	Visual	Bolts, nuts and rivets should not be loose.	Tighten or replace as required.
Wire Rope Wedge	Visual	The fixing (anchorage with wedge) must be replaced if it shows deformation, wear, cuts, or necking.	Replace
Wire Rope Drum	Visual, Function	Entire surface of the drum should be coated with lubricant and should be free of dirt and grime. Rope should fit in drum grooves.	Clean/lubricate (see Section 6.1).
Wire Rope Guide	Visual, Function	Rope Guide should be free of significant wear, cracks, nicks, gouges, dirt and grime. Rope Guide should take up rope play and move with the rope on the drum during rope unwinding and winding.	Replace
Wire Rope – Reeving	Visual	The wire rope should be reeved properly through Hook Block Sheave (and Crossbar Sheave for 4/1 hoist) – refer to Section 3.6 . Wire rope should be installed properly – refer to Section 6.4 .	Reeve/Install properly.

Table 5-5 Hoist (and Trolley) Inspection Methods and Criteria (continued)

Item	Method	Criteria	Action
<p>⚠ WARNING The full length of the Wire Rope must be inspected for rope diameter, Broken strands or wires, and condition. Special care should be taken when inspecting sections of rapid deterioration, such as the following:</p> <ul style="list-style-type: none"> ▪ sections in contact with saddles, equalizer sheaves, or other sheaves where the rope travel is limited; ▪ sections of the rope at or near terminal ends where corroded or broken wires may protrude; ▪ sections subject to reverse bends; ▪ sections of rope that are normally hidden during visual inspection, such as parts passing over sheaves. <p>Any condition that could degrade the strength and performance of the wire rope must be reported to a qualified person for evaluation and disposition.</p>			
Wire Rope Diameter	Measure, Visual	Any reduction in the diameter of the wire rope must not be reduced due to corrosion, wear or core collapse more than the discard value in Table 5-7 . The outer wires should not be worn more than 1/3 of their original diameter.	Replace. Inspect drum and all sheaves.
Wire Rope – Broken Wires or Strands	Visual	<p>The wire rope should be inspected for broken wires or strands, paying close attention to end connection and sections that frequently pass over sheaves. The rope must NOT have:</p> <ul style="list-style-type: none"> ▪ More than the Maximum number of broken wires listed in Table 5-7. ▪ More than 4 broken wires in 1 strand in one lay (one full revolution of a strand around the rope). ▪ Any broken strands. 	Replace
Wire Rope – Condition	Visual	<ul style="list-style-type: none"> ▪ Any wire rope deformation with permanent bends, flattening, unraveling, birdcaging, etc. ▪ General corrosion. ▪ Rope core exposure. ▪ One or more loose or protruding strands or wires from rope. ▪ Severely corroded or broken wires at end connections. ▪ Severely corroded, cracked, bent, worn or improperly applied end connections ▪ Any evidence of heat damage of any kind. (Wire rope exhibits any heat discoloration or localized loss of lubrication). 	Replace
Wire Rope - Lubrication	Visual	The wire rope must be maintained in a clean and well lubricated condition.	Clean/lubricate (see Section 6.1).
Trolley Side Plates	Visual	Must be free of significant deformation	Replace
Trolley Wheel – Condition	Visual	Trolley Wheel should be free of significant wear, cracks, nicks and gouges.	Replace.

Table 5-5 Hoist (and Trolley) Inspection Methods and Criteria (continued)

Item	Method	Criteria	Action
Trolley Wheel – Tread	Visual, Measure	Diameter of the tread surface should not be less than 5% of its original diameter as new.	Replace.
Trolley Wheel – Gear	Visual	Teeth should not be cracked, damaged, or excessively worn.	Replace.
Load Bar	Visual, Measure	Load Bar should be free of significant wear, cracks, nicks and gouges. Load Bar should not be bent.	Replace.
Trolley Motor Brake	Visual	Braking action should not be overly abrupt and should not allow excessive drift.	Adjust, Repair or Replace as required.
Contactors Contacts	Visual	Contacts should be free of significant pitting or deterioration.	Replace.
Sheaves	Visual	Sheave should be free of significant wear.	Replace.
Pendant – Switches	Function	Depressing and releasing push buttons should make and break contacts in switch contact block and result in corresponding electrical continuity or open circuit. Push buttons should be interlocked either mechanically or electrically to prevent simultaneous energizing of circuits for opposing motions (e.g. up and down, forward and reverse).	Repair or replace as necessary.
Pendant - Housing	Visual	Pendant housing should be free of cracks and mating surfaces of parts should seal without gaps.	Replace
Pendant - Wiring	Visual	Wire connections to switches in pendant should not be loose or damaged.	Tighten or repair
Pendant and Power Cords	Visual, Electrical Continuity	Surface of cord should be free from nicks, gouges, and abrasions. Each conductor in cord should have 100% electrical continuity even when cord is flexed back-and-forth. Pendant Cord Strain Relief Cable should absorb the entire load associated with forces applied to the pendant.	Replace
Pendant - Labels	Visual	Labels denoting functions should be legible.	Replace
Warning Labels	Visual	Warning Labels should be affixed to the hoist (see Section 1.2) and they should be legible.	Replace
Hoist Capacity Label	Visual	The label that indicates the capacity of the hoist should be legible and securely attached to the hoist.	Replace

Table 5-6 Bottom Hook Dimensions

g1 Measured When New:

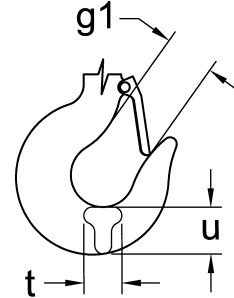

Hook Identifier (10 th Character of the Hoist Product Code)	Nominal (g1) Dimension* inch (mm)	(u) Dimension inch (mm)		(t) Dimension inch (mm)	
		Standard	Discard	Standard	Discard
G (4 Falls)	1.97 (50)	2.28 (58)	2.17 (55.1)	1.77 (45)	1.68 (42.8)
L (4 Falls)	2.48 (63)	2.95 (75)	2.81 (71.3)	2.36 (60)	2.24 (57)

*These values are nominal since the dimension is not controlled to a tolerance. The “g1” dimension should be measured when the hook is new – this becomes a reference measurement. Subsequent measurements are compared to this reference to make determinations about hook deformation/stretch. See Section 5.7, “Hooks – Stretch”.

Table 5-7 Wire Rope Wear Dimensions

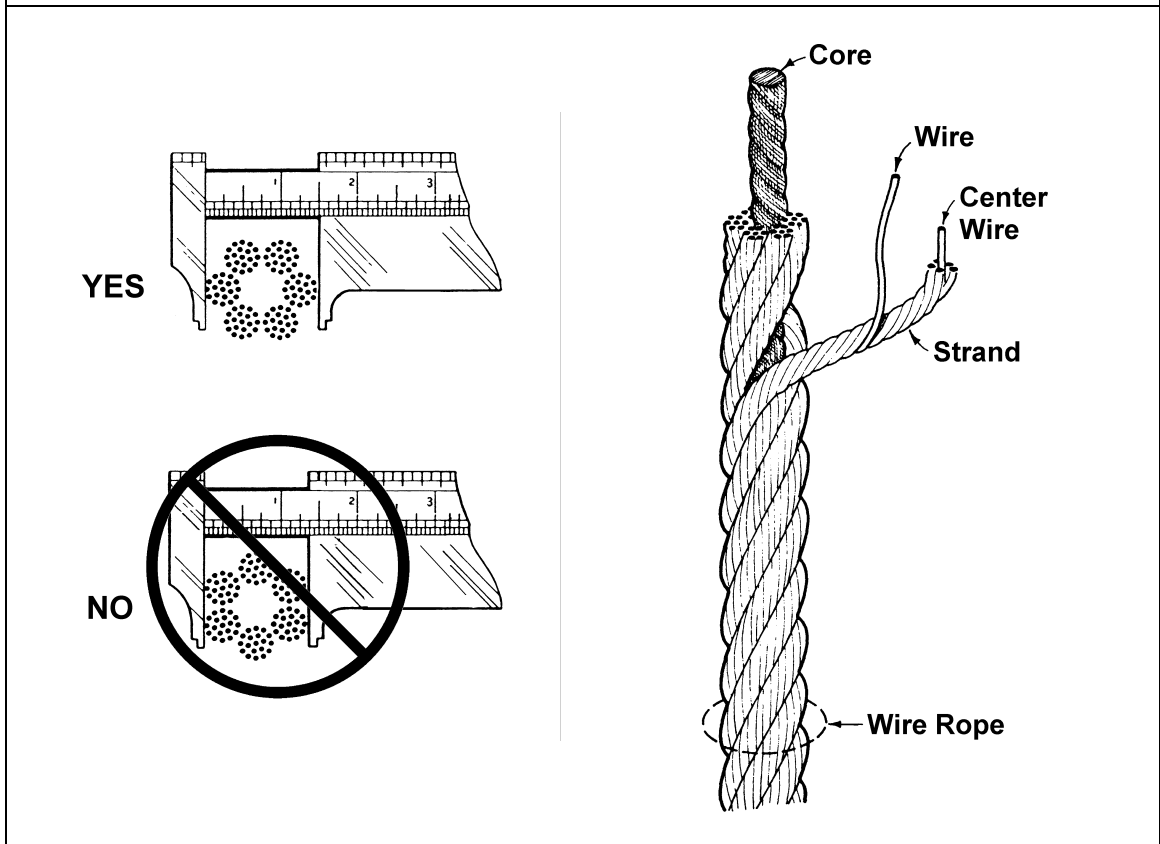

Hoist Size	Rope Diameter			Maximum Allowable Number of Broken Wires				
	Standard (mm)	Discard		Rope Diameter (mm)	For 6xDia. Length		For 30xDia. Length	
		(mm)	(in)		No. Broken Wires	Length (in)	No. Broken Wires	Length (in)
2	9	8.4	0.33	9	3	2.1	6	10.6
3	13	12.1	0.48	13	7	3.1	14	15.4

Table 5-8 Braking Distance (inches) With Nominal Load

No. of Falls	Speed	HOIST SIZE* ⇒	1	2	3	4
4 Fall	16 ft/min	Maximum Limit Before Adjustment	1.77	2.36	2.95	3.54
		Best Value Following Adjustment	0.59	0.79	0.98	1.18

*To determine the hoist size, refer to Section 2.1.2.

6.0 Maintenance and Handling

6.1 Lubrication

6.1.1 Wire Rope:

- + For proper performance the Wire Rope must be maintained in a clean and well lubricated condition.
- + The rope should be lubricated every 3 months (more frequently for heavier usage or severe conditions).
- + To lubricate the rope, first remove any dirt, grime, moisture or other accumulations of contaminants. Then coat the Wire Rope with Agip 360 EP/F oil or equivalent. Ensure that the lubricant is applied to the entire surface of the rope over its entire length.

6.1.2 Wire Rope Drum, Hook Block and Sheaves:

- + The drum and hook block should be lubricated every 3 months (more frequently for heavier usage or severe conditions).
- + Lubricate the Drum, Hook Block and Sheaves with Agip Blasia 320 oil or Agip Blasia GR MU3 grease.

6.1.3 Trolley Wheels and Gears:

- + The Trolley Wheels and Gears should be lubricated every 3 months (more frequently for heavier usage or severe conditions).
- + Lubricate the Trolley Wheels and Gears with Agip Blasia GR MU3 grease

6.1.4 Hoist and Trolley Gearboxes – The hoist and trolley gearboxes are lubricated for life and should not need any lubricant replacement.

6.2 Hoist Motor Brake

6.2.1 To keep your hoist working in optimum condition and prevent possible down time, it is recommended to check your motor brake and adjustment at regular intervals.

6.2.2 Motor brake adjustment is as follows:

- 1) **⚠ DANGER** Before proceeding, ensure that the electrical supply for the hoist or trolley has been de-energized (disconnected). Lock out and tag out in accordance with ANSI Z244.1 “Personnel Protection –Lockout/Tagout of Energy Sources”.
- 2) Adjustment and inspection of the motor brake requires removal of the motor brake cover from the hoist.
- 3) To remove the cover (A), remove the 4 Cover Screws (B), then remove the Cover (see Figure 6-1).
- 4) Remove the 3 screws (E) from the Blocking Ring (D) of the brake lock (see Figure 6-2).
- 5) To adjust the brake, rotate the Blocking Ring (D) counterclockwise to increase brake pressure, clockwise for less pressure. One complete revolution is equal to 1mm of axial movement. Moving the ring may require using a screwdriver in the notch of the Blocking Ring (D) (see Figure 6-3)

6.2.3 Motor Brake Re-assembly – After the brake is properly adjusted and inspected, reassemble the parts in reverse order of removal.

6.2.4 Motor Brake Check

- 1) Ensure that the motor runs freely and quietly.
- 2) Ensure that the brake is not overheating.

- 3) Check that the brake adjustment has been performed correctly. Complete the brake test, first with no load and then with a nominal load (see Table 5-8).
- 4) Readjust the brake as necessary.
- 5) It is recommended that the brake be replaced after 3 adjustments.

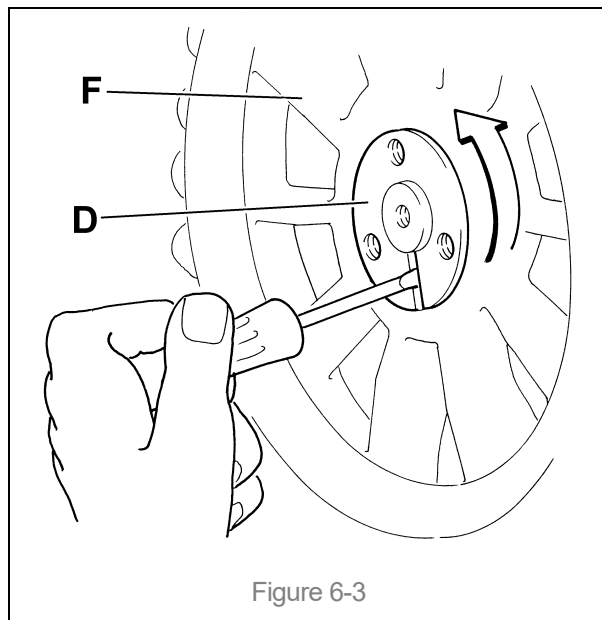
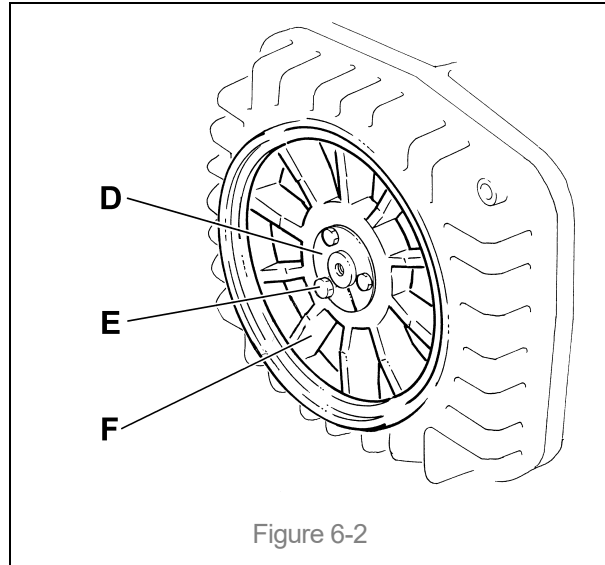
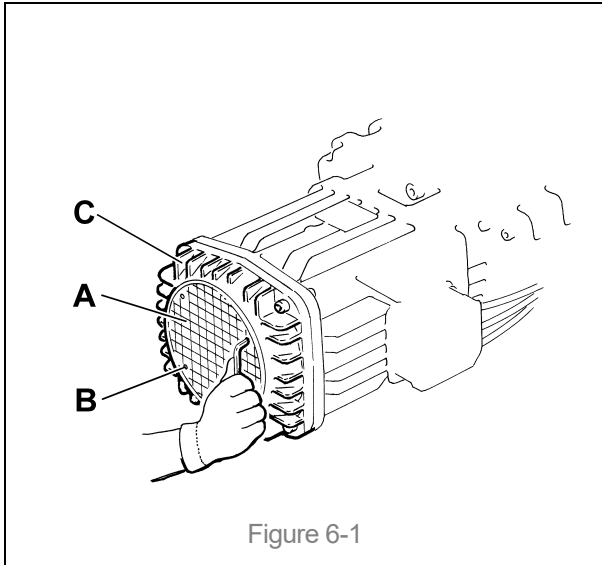

6.3 Trolley Motor Brake

6.3.1 The Trolley Brake adjustment can be accomplished 2 ways:

- + External Method – External adjustment in the case of moderate wear or when changing the brake pre-sets.
- + Internal Method – Internal adjustment is required after the External method does not provide enough braking. This usually occurs when brake wear exceeds 1mm.

6.3.2 To adjust the trolley motor brake for either the external or internal method, it is necessary to perform the following steps:

1) **⚠ DANGER** Before proceeding, ensure that the electrical supply for the hoist or trolley has been de-energized (disconnected). Lock out and tag out in accordance with ANSI Z244.1 “Personnel Protection –Lockout/Tagout of Energy Sources”.

2) Remove the trolley Motor Cover (A) by unscrewing the 4 Screws (B) (see Figure 6-4).

6.3.3 External Method – The external method allows the braking force to be increased or decreased as required without disassembling the brake.

1) Remove the Lock-Nut®, Fan (D), external Thickness Washers (E), Snap Ring (F), Pressure Washer (G) and Spring (H) (see Figure 6-5 and 6-6).

2) To INCREASE braking, add some or all of the external Thickness Washers (E) to the Thickness Washers (E) adjacent to the motor as necessary to obtain the required braking force (see Figure 6-6).

3) To DECREASE braking, remove a quantity of the internal Thickness Washers (E) adjacent to the motor and add them to the external Thickness Washers (E) during re-assembly (between the fan (D) and the snap ring (F) as required to obtain the required decrease in braking force (see Figure 6-6).

4) Reinstall the Spring (H), Pressure Washer (G), Snap Ring (F), Thickness Washers (E), Fan (D) and Lock-Nut®.

5) Reinstall the trolley Motor Cover (A) using the 4 Screws (B).

6) Perform brake tests and repeat the above steps as necessary to obtain the required trolley braking.

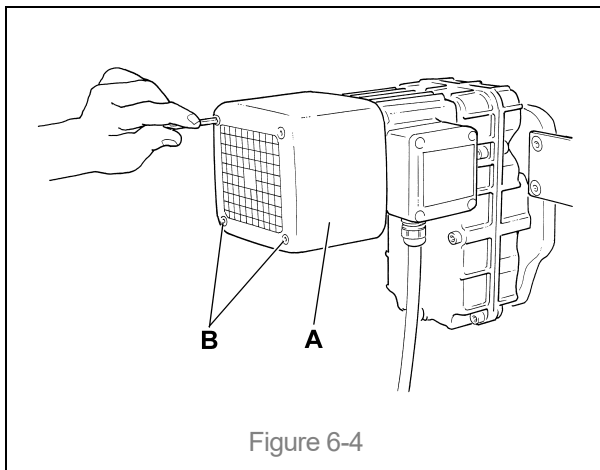

Figure 6-4

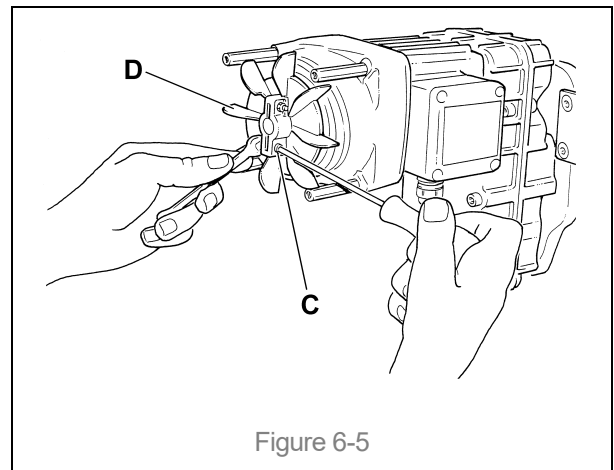
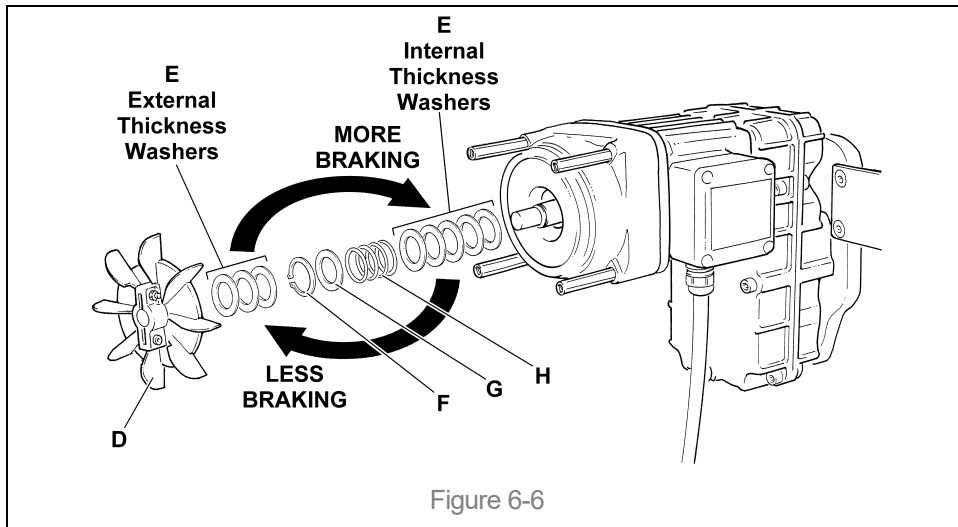

Figure 6-5



6.3.4 Internal Method – The internal method allows the braking to be increased as required.

- 1) Remove the Lock-Nut®, Fan (D), Snap Ring (F), Pressure Washer (G), Spring (H) and all Thickness Washers (E) (see Figure 6-5 and 6-6).
- 2) Unscrew and remove the Hexagonal Spacers (J) and Nuts then remove the Motor Cover (P). Carefully, so as not to damage the rotor and/or the winding, slide the Rotor (N) with Brake Block (K) out of the motor completely (see Figure 6-7).
- 3) Remove the Snap Ring (L), external Drum Spacers (M), Brake Block (K), without removing the internal Drum Spacers (M) nearest the rotor. Transfer the necessary quantity of external Drum Spacers (M) to the Rotor (N) side of the brake block (K) to provide more braking (see Figure 6-8).
- 4) Reinstall the brake block (K), Drum Spacers (M), Snap Ring (L) and reinsert the rotor in the motor. Reinstall the Motor Cover (P), Hexagonal Spacers (J) and Nuts (see Figure 6-9).
- 5) Confirm acceptable trolley braking distance. Perform the steps of Section 6.3.3 External Trolley Brake Adjustment for further adjustment if necessary.

6.3.5 If the adjustment has been performed several times and the required braking cannot be obtained, it is necessary to replace the motor cover (P), ordering ONLY original spare parts.

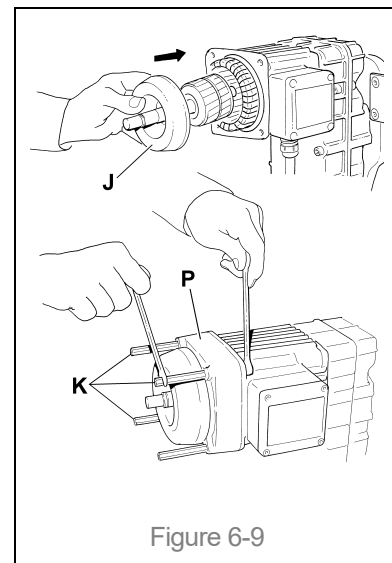
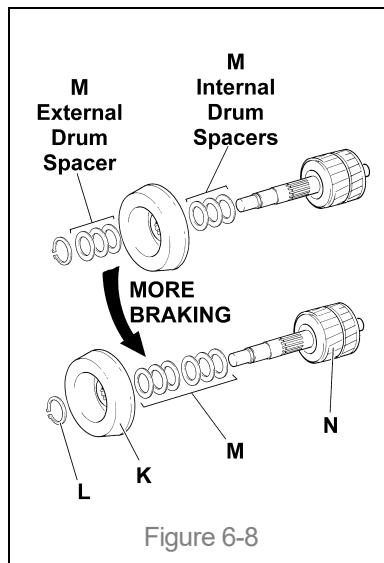
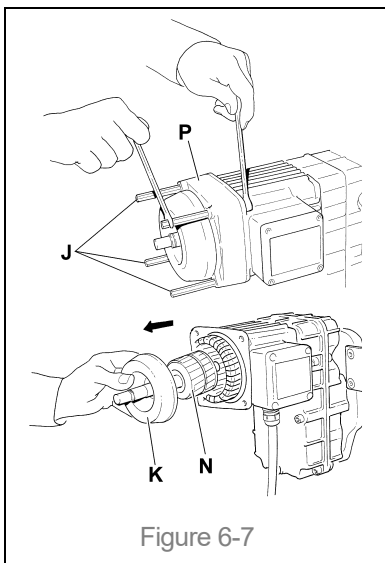

6.4 Wire Rope

6.4.1 Lubrication and Cleaning – Refer to Section 6-1.

6.4.2 **⚠ WARNING** Although the 5T and 7½T wire rope have the same diameter, 9mm, they are very different wire rope rated for the specific capacity. The 5 Ton wire rope, part numbers DRH270540 (23 foot lift) and DRH270560 (33 foot lift), **must not** be installed on or used on the 7½ Ton US trolley hoist. The DRH270540 (23 foot lift) and DRH270560 (33 foot lift) wire ropes **are not** rated for 7½ Ton US use.

6.4.3 **⚠ WARNING** Be certain that the replacement wire rope is obtained from Harrington Hoists, Inc. and is the correct wire rope for the hoist. If the wire rope is being replaced due to damage or wear out, destroy the old rope to prevent its reuse.

6.4.4 Wire Rope Removal

- 1) **⚠ CAUTION** The hoist must be properly powered and operational in order to perform the following procedures.
- 2) **⚠ CAUTION** It is strongly advised to use the Wire Rope Guide Tool (part number, DMFOA0000) during rope replacement. The Wire Rope Guide Tool is available from Harrington Hoists, Inc. (see Figure 6-10).
- 3) **⚠ CAUTION** When replacing Wire Rope, check for wear on mating parts, i.e. Drum, Sheaves, Hook Block Sheaves and replace if necessary.
- 4) Lower the Hook Block to the lowest possible position without touching the floor or ground.
- 5) Remove the Anchorage Assembly (F) by removing Pin (D) from the Terminal Head Cross Bar (A) to free the lever of the Load Limiter (C) (see Figure 6-11).
- 6) Rotate the lever downwards until the Anchorage Pin (E) can be removed allowing the Anchorage (F) to be removed for disassembly.
- 7) Remove the Wire Rope Clamp (G) and loosen the Wire Rope until the Terminal Wedge (H) can be removed from the Anchorage Assembly (F) (see Figure 6-12).
- 8) Remove (unreeve) the Wire Rope from the Bottom Block and all Sheaves.

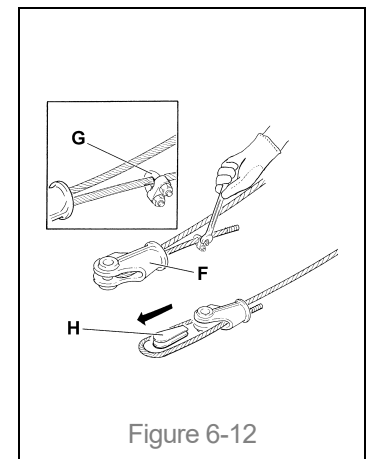
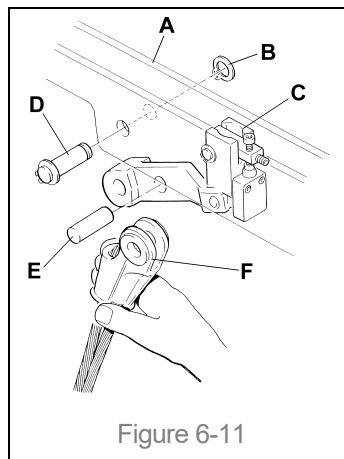
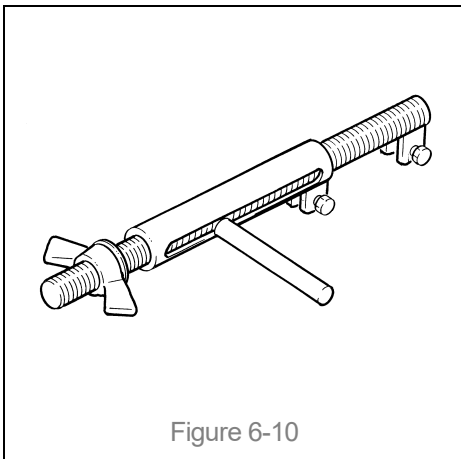

- 9) Remove the Dust Cover (K) by unscrewing the Dust Cover Screws (J) (see Figure 6-13). Note: Dust cover is an option and may not be present.
- 10) Gain access to the Rope Guide and associated components. Remove the Limit Switch Assembly (C1) removing the Screws (D1). Do not disconnect or change the setting of the Limit Switches (see Figure 6-14).
- 11) Remove the Screws (N) and the Limit Switch Actuators (N) from the Rope Guide Ring Halves (P) and (Q) (see Figure 6-15).

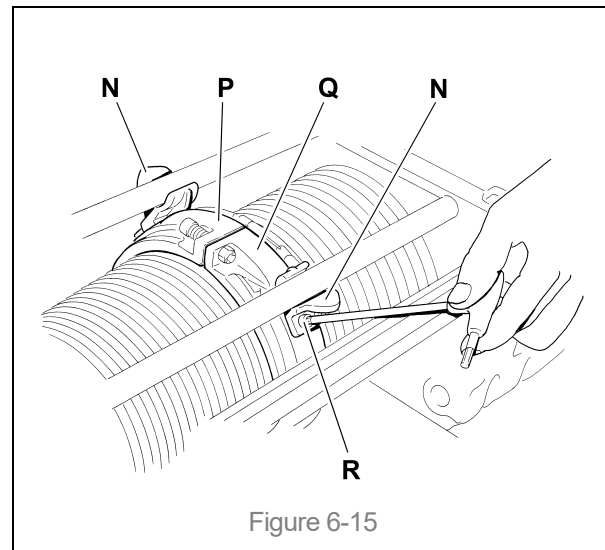
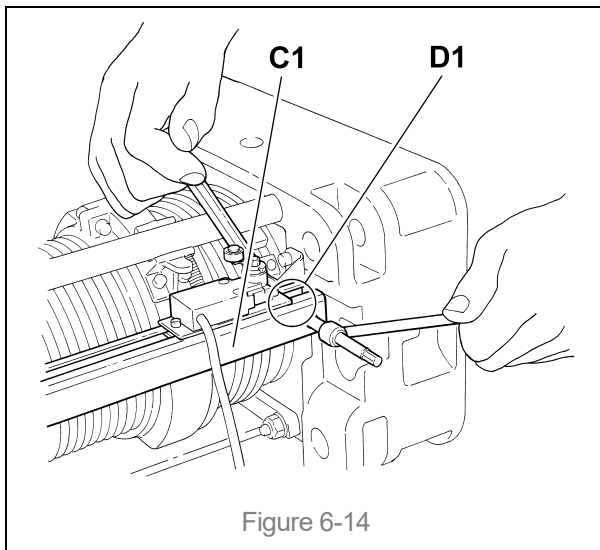
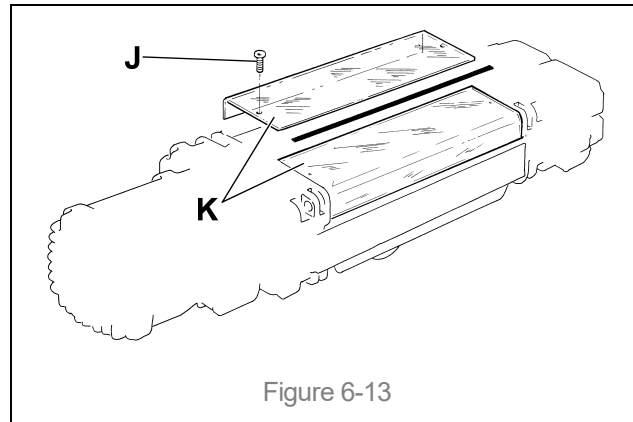

- 12) Remove the Wire Clamping Spring (T) using the Wire Rope Guide Clamping Tool (S) and pliers to remove the Clip (U) (see Figure 6-16).
- 13) Unscrew the Nuts (X) remove the Screws (V) and the Springs (W) from the Rope Guide Ring Halves (P and Q), then remove the Ring Half (Q) (see Figure 6-17).
- 14) Loosen the Screws (A1) of the Wire Rope Clamps (B1) and take out the Wire Rope and Ring Half (P) (see Figure 6-18). For 4/1 Ultra-Low headroom versions it is necessary to rotate the Ring Half (P) over the top of the drum to remove it from the hoist (see Figure 6-19).

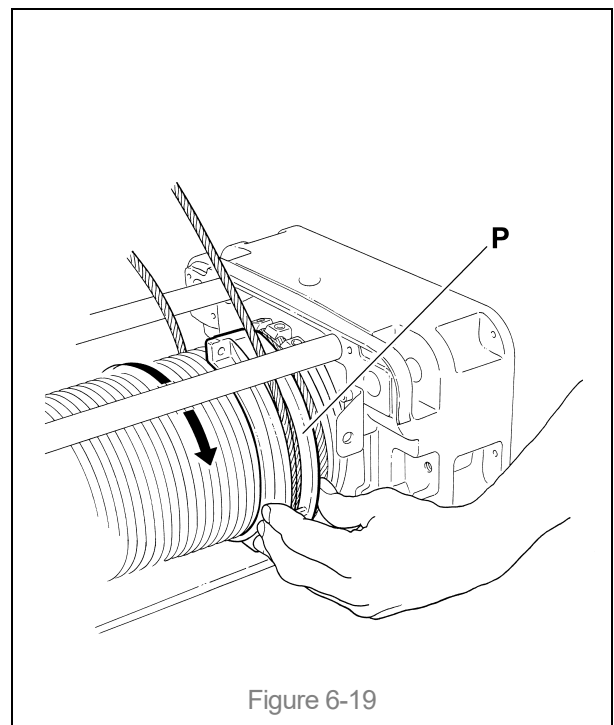
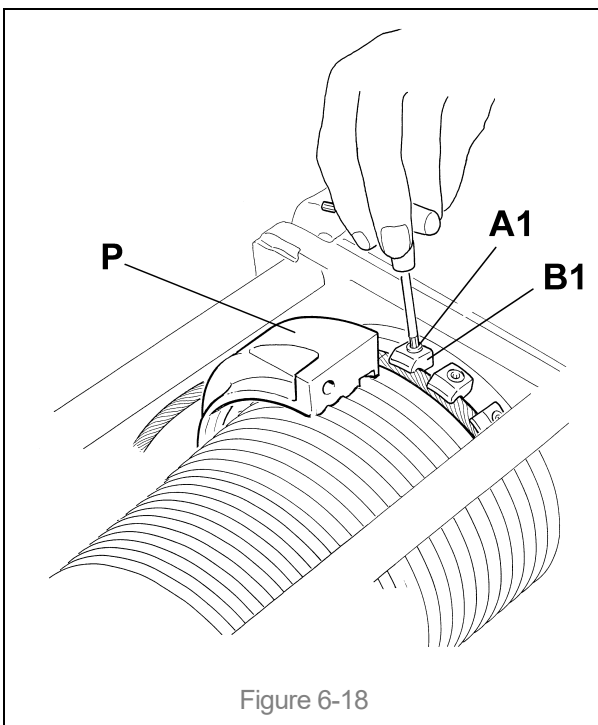
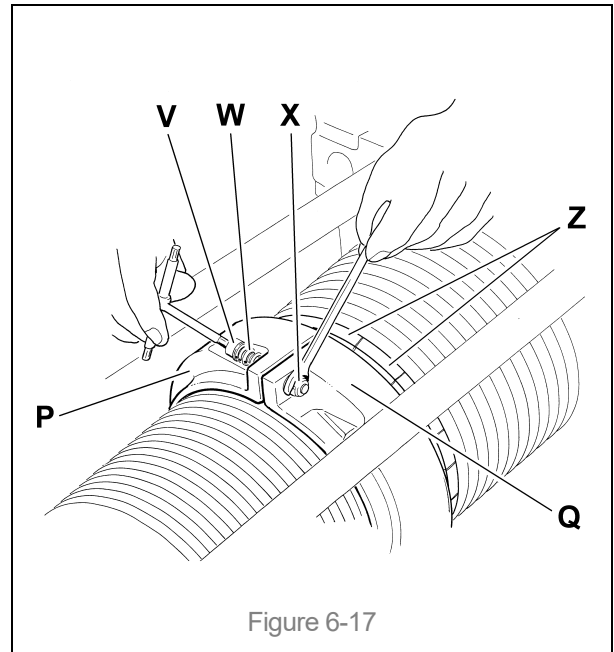
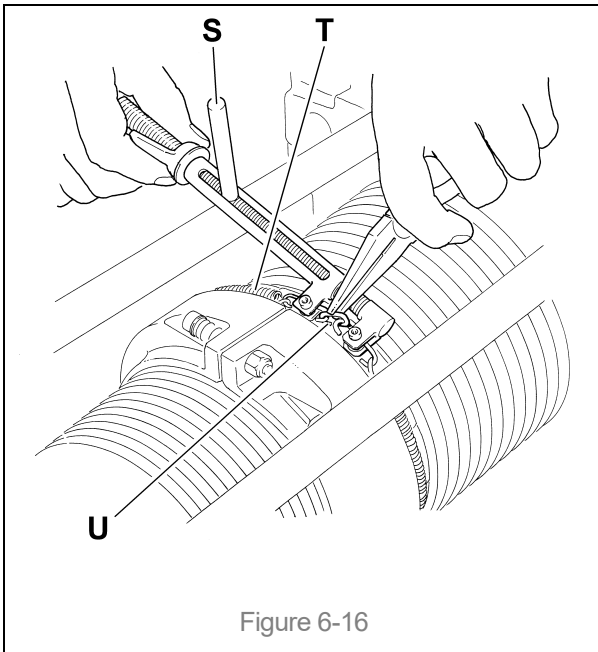

6.4.5 Wire Rope Installation

- 1) **⚠ CAUTION** The hoist must be properly powered and operational in order to perform the following procedures.
- 2) **⚠ WARNING** Although the 5T and 7½T wire rope have the same diameter, 9mm, they are very different wire rope rated for the specific capacity. The 5 Ton wire rope, part numbers DRH270540 (23 foot lift) and DRH270560 (33 foot lift), **must not** be installed on or used on the 7½ Ton US trolley hoist. The DRH270540 (23 foot lift) and DRH270560 (33 foot lift) wire ropes **are not** rated for 7½ Ton US use.
- 3) **⚠ CAUTION** When replacing Wire Rope, check for wear on mating parts, i.e. Drum, Sheaves, Hook Block Sheaves and replace if necessary.
- 4) **⚠ WARNING** ALWAYS unwind the roll of the new Wire Rope without kinks or bends (see Figure 6-20).
- 5) Examine the Wire Rope Guide Ring Halves (P) and (Q) and the Drum after cleaning/degreasing thoroughly.
- 6) Verify proper fit of the Wire Rope Guide Ring Halves (P) and (Q) with the Drum, matching up the respective grooves and check that there is no excessive clearance. Check for pointed or sharp crests and heavy wear and tear. Where necessary assess the need for replacing the wire rope guides and the Drum.
- 7) Securing the Wire Rope to the Drum:

Pass the end of the new Wire Rope up between the beam and the Drum, directly over the Drum, and insert it through the “slit” of the Rope Guide Ring Half (P). Rotate the Rope Guide Ring Half (P) directly over the Drum into position between the beam and Drum (see Figure 6-22). Secure the end of the Wire Rope to the Drum with 3 Wire Rope Clamps (B1). Torque the Screws (A1) to the value shown in Table 6-1 for your hoist (see Figure 6-21).

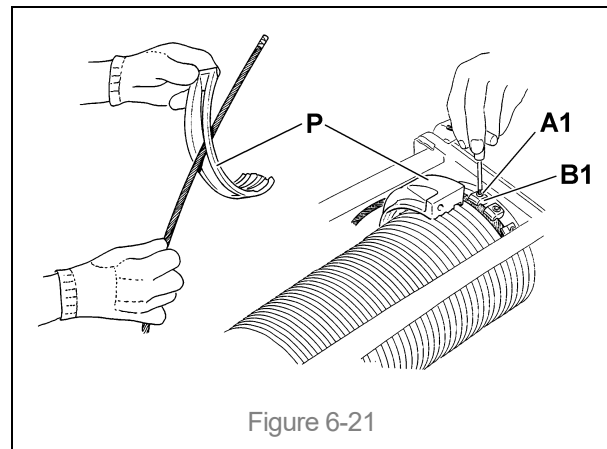
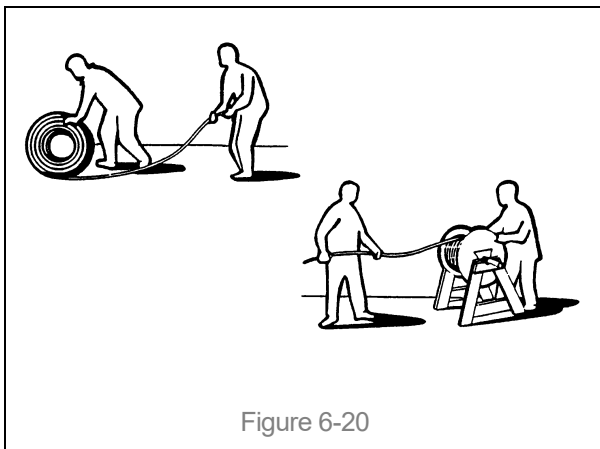

Hoist Size	2	3
Screw (A1) Dia (mm)	M6	M8
Screw (A1) Torque	71 in-lbs	15 ft-lbs

- 8) Press the "UP" button on the Pendant to wind the Wire Rope onto the Drum. Use protective gloves to keep the Wire Rope constantly taut and well placed in the Drum grooves, letting the Wire Rope wind around for at least 10 times (see Figure 6-23).
- 9) Without loosening the tension on the Wire Rope, clamp a weight onto the Wire Rope below the Rope Guide, taking care not to damage the Wire Rope. Replacing the manual tension with the weight will prevent the Wire Rope from unrolling off the Drum (see Figure 6-24).
- 10) Place both Rope Guide Ring Halves (P) and (Q) together on the Drum. Insert the Screws (V) and the Springs (W) and tighten the Lock Nuts (X) until the Springs are partially collapsed, taking care not to over-tighten the Springs, keeping the whole Rope Guide System elastic. Make sure at least 2 threads protrude past the Lock Nuts (X) (see Figure 6-25).

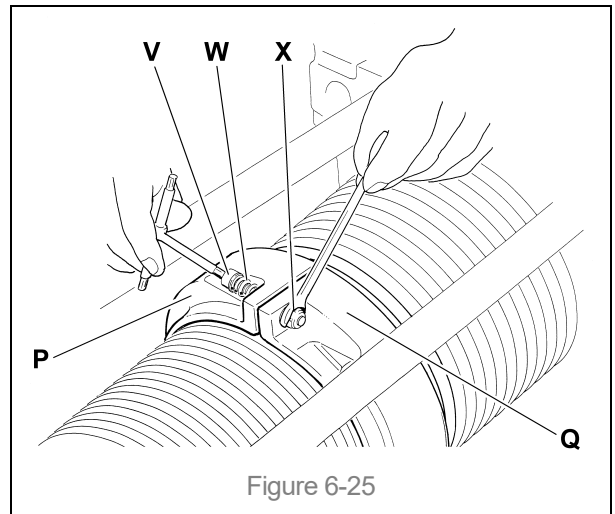
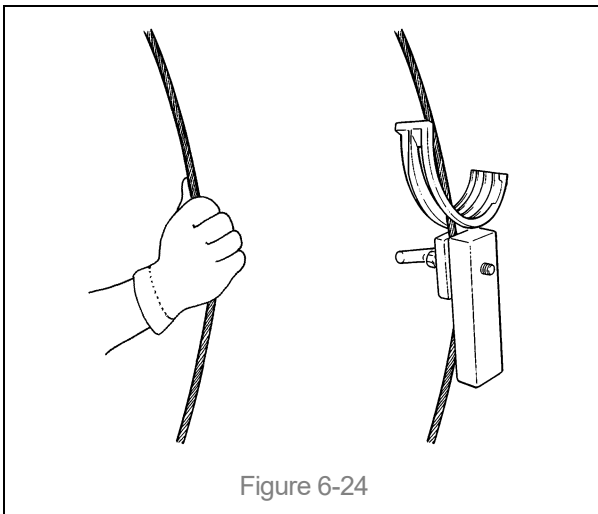
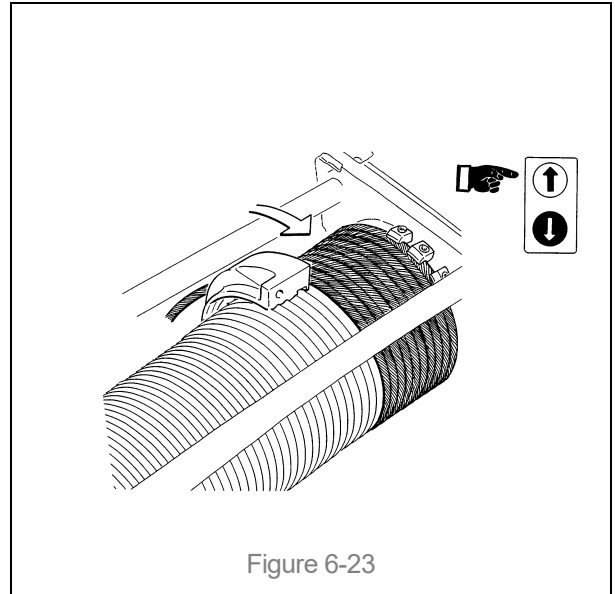
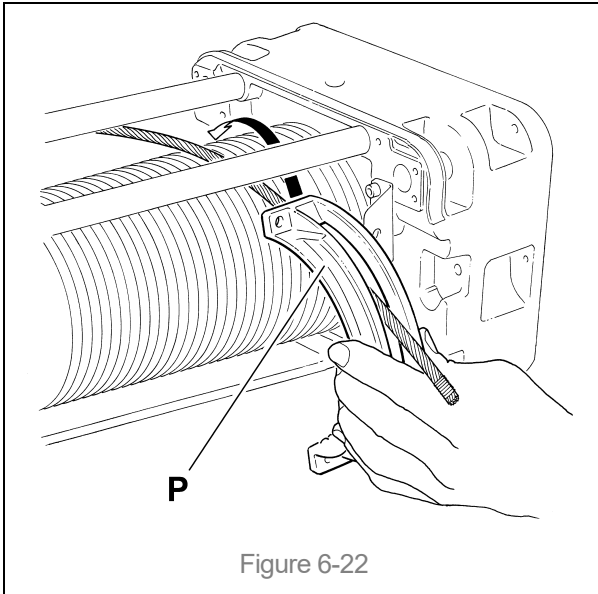

- 11) Insert the Wire Rope Clamp Runners (Z) piece by piece, into the slot on the side of the Rope Guide Ring (P) (see Figure 6-26).
- 12) Reinstall the Limit Switch Actuators (N) onto the Rope Guide Ring Halves (P) and (Q) and tighten the Screws (R) (see Figure 6-27).
- 13) Reposition the Wire Clamping Spring (T) on the Runners (Z). Use the Wire Rope Guide Clamping Tool (S), to pull the Spring taut. Couple the ends of the Clip (U) onto the Spring using the pliers (see Figure 6-28).
- 14) Complete Reassembly:

Reinstall the Limit Switch Assembly (C1) and tighten the Screws (D1). Do not disconnect or change the setting of the Limit Switches (see Figure 6-29). Reinstall the Dust Cover Halves (K) and tighten the four (4) Screws (J) (see Figure 6-30). Note: Dust cover is an option and may not be present.

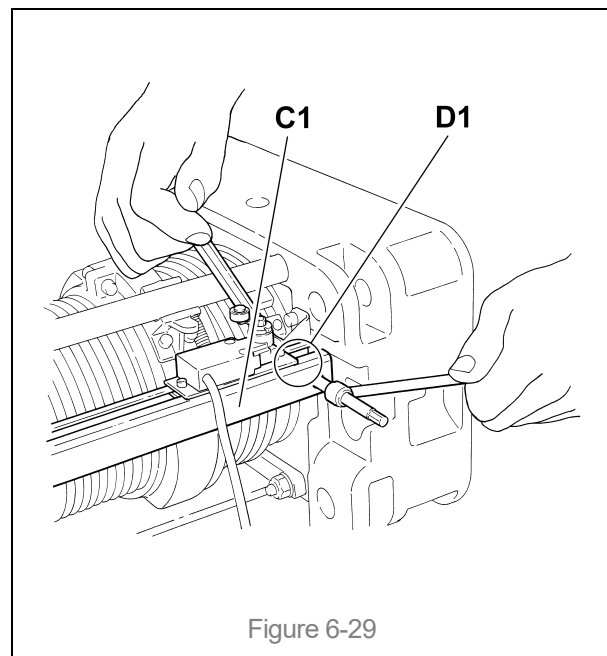
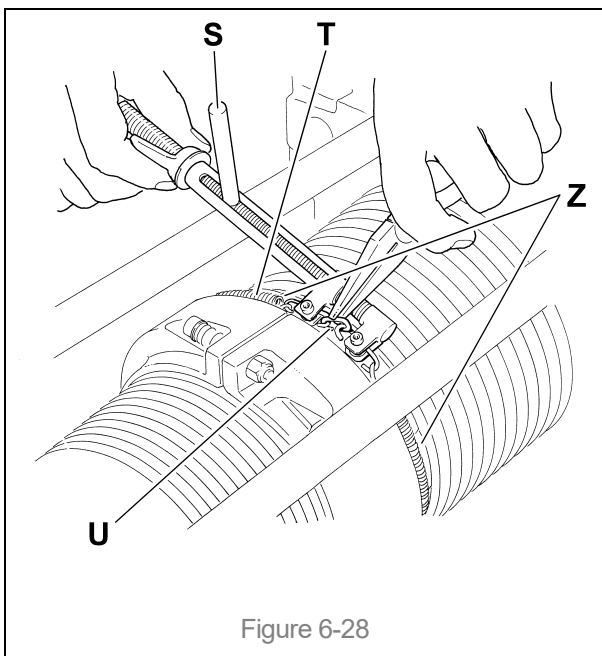
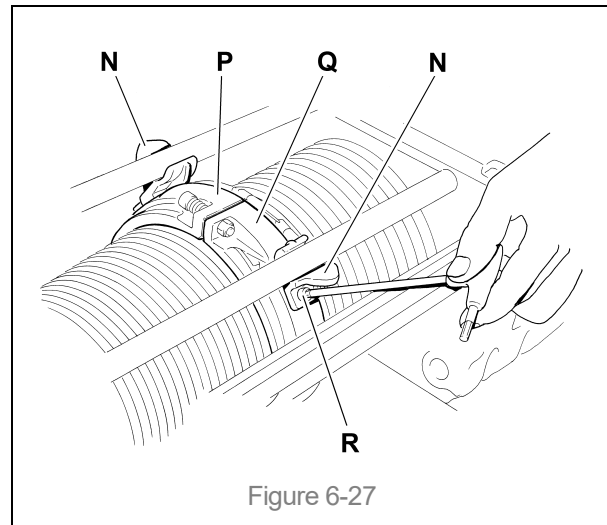
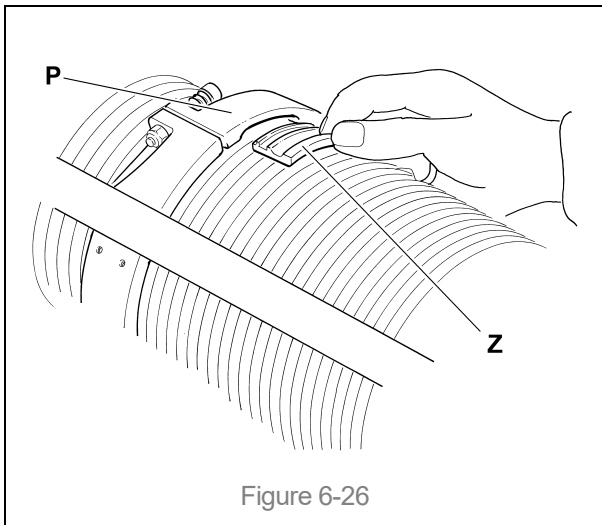

- 15) Carry out again all the sequences described in Section 3.6 “Reeving and Adjustments”. Lubricate the Wire Rope, the Rope Guide and Drum (see Section 6.1).

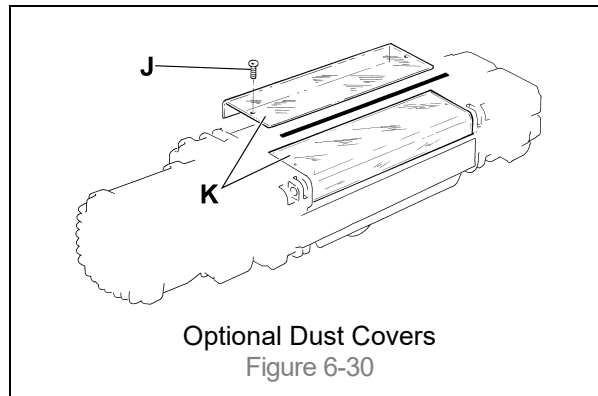

6.5 Storage

- 6.5.1 The storage location should be clean and dry.
- 6.5.2 Care should be taken to not damage any of the electrical power cords or fittings.

6.6 Outdoor Installations

- 6.6.1 For trolley and hoist installations that are outdoors, the trolley and hoist should be covered and protected from the weather at all times.
- 6.6.2 Possibility of corrosion on components of the trolley increases for installations where salt air and high humidity are present. The hoist and trolley may require more frequent lubrication. Make regular inspections of the unit's condition and operation.
- 6.6.3 Optional weatherization package should be considered for high salt air and/or humid environments.

7.0 Troubleshooting

WARNING

HAZARDOUS VOLTAGES ARE PRESENT IN THE HOIST AND IN CONNECTIONS BETWEEN COMPONENTS.

Before performing ANY troubleshooting on the equipment, de-energize the supply of electricity to the equipment, and lock and tag the supply device in the de-energized position. Refer to ANSI Z244.1, "Personnel Protection - Lockout/Tagout of Energy Sources."

Only Trained and competent personnel should inspect and repair this equipment.

Table 7-1 Troubleshooting Guide

Symptom	Cause	Remedy
Hoist and/or Trolley moving in wrong direction	Power supply reversed phased	Switch two (2) of the three (3) power supply cord wires at the power source.
	Improper electrical connections	Refer to wiring diagram and check all connections.
Hoist and/or Trolley will not operate	Loss of power	Check circuit breakers, switches, fuses and connections on power lines/cable.
	Wrong voltage or frequency	Check voltage and frequency of power supply against the rating on the nameplate of the motor.
	Hoist overload	Reduce load to within rated capacity of hoist.
	Motor overheated and thermal overload protector has tripped	See Trouble Shooting Problem "Motor or brake overheating".
	Improper, loose, or broken wire in hoist electrical system	Shut off power supply, check wiring connections on hoist control panel and inside push-button pendant.
	Brake does not release	Check motor brake adjustment for proper clearance.
	Defect in control transformer	Check transformer coil for signs of overheating. Disconnect transformer and check for open winding.
	Faulty magnetic contactor	Check coil for open or short circuit. Check all connections in the control circuit. Check for open contactors. Replace as needed.
	Faulty Up or Down Limit Switch	Replace the Up and/or Down Limit Switch
	Motor burned out	Replace motor frame/stator, shaft/rotor, and any other damaged parts.

Table 7-1 Troubleshooting Guide

Symptom	Cause	Remedy
Hoist lifts but will not lower	Down circuit open	Check circuit for loose connections. Check down limit switch for malfunction.
	Broken conductor in pendant cord	Check the continuity for each conductor in the cable. If one is broken, replace entire cable.
	Faulty magnetic contactors	Check coils for open or short circuit. Check all connections on motor circuit. Check for burned contacts. Replace as needed.
	Faulty switch in pendant	Check electrical continuity. Check electrical connections. Replace or repair as needed.
Hoist lowers but will not lift	Hoist overloaded	Reduce load to within rated capacity of hoist.
	Low voltage in hoist's power supply	Determine cause of low voltage and bring to within plus or minus 10% of the voltage specified on the motor nameplate. The voltage should be measured at the hoist contactor.
	Up circuit open	Check circuit for loose connections. Check up limit switch for malfunction.
	Faulty magnetic contactors	Check coils for open or short circuit. Check all connections on motor circuit. Check for burned contacts. Replace as needed.
	Broken conductor in pendant cord	Check the continuity of each conductor in the cable. If one is broken, replace entire cable.
	Faulty switch in pendant	Check electrical continuity. Check electrical connections. Replace or repair as needed.
Hoist will not lift rated load or does not have the proper lifting speed	Hoist overloaded	Reduce load to within rated capacity.
	Low voltage in hoist's power supply	Determine cause of low voltage and bring to within plus or minus 10% of voltage specified on the motor nameplate. The voltage should be measured at the hoist contactor.
	Brake drags	Check motor brake adjustment for proper clearance.
Load drifts excessively when hoist is stopped	Motor brake not holding	Clean and inspect brake lining. Check brake adjustment for proper clearance.
Trolley drifts excessively when stopping	Motor brake not holding	Clean and inspect brake lining. Check brake adjustment. Replace if necessary
Hoist and/or Trolley Motor or brake overheating	Excessive load	Reduce load to within rated capacity of hoist.
	Excessive duty cycle	Reduce frequency of lifts and/or trolley movement.
	Wrong voltage or frequency	Check voltage and frequency of power supply against the rating on the nameplate on the motor.
	Brake drags	Check brake adjustment for proper clearance.
	Extreme external heating	Above an ambient temperature of 104°F, the frequency of hoist operation must be reduced to avoid overheating of the motor. Special provisions should be made to ventilate the hoist or otherwise shield it from the heat.

Table 7-1 Troubleshooting Guide

Symptom	Cause	Remedy
Hoist and/or Trolley operates intermittently	Contactors contacts arcing	Check for burned contacts. Replace as needed.
	Loose connection in circuit	Check all wires and terminals for bad connections. Replace as needed.
	Broken conductor in Pendant Cord	Check for intermittent continuity in each conductor of the Pendant Cord. Replace entire Pendant Cord if continuity is not constant.
Trolley making loud noise.	Trolley wheel maladjusted on beam	Readjust the gap between the trolley wheel flange and the beam flange.
Trolley will not move	Trolley wheel spacing on beam too tight	Readjust the gap between the trolley wheel flange and the beam flange.
Abnormal noise from wire rope and/or drum	Lack of lubrication, worn wire rope/drum/sheaves	Lubricate or replace wire rope/drum/sheaves

8.0 Warranty

Warranty explanation and terms.

All products sold by Harrington Hoists, Inc. are warranted to be free from defects in material and workmanship from date of shipment by Harrington for the following periods:

- 1 year – Electric and Air Powered Hoists (excluding (N)ER2 Enhanced Features Models), Powered Trolleys, Powered Tiger Track Jibs and Gantries, Crane Components, Below the Hook Devices, Spare / Replacement Parts**
- 2 years – Manual Hoists & Trolleys, Beam Clamps**
- 3 years – (N)ER2 Enhanced Features Model Hoists**
- 5 years – Manual Tiger Track Jibs and Gantries, TNER Pull - Rotor Motor Brake**
- 10 years – (N)ER2 “The Guardian” Smart Brake**

The product must be used in accordance with manufacturer’s recommendations and must not have been subject to abuse, lack of maintenance, misuse, negligence, or unauthorized repairs or alterations.

Should any defect in material or workmanship occur during the above time period in any product, as determined by Harrington Hoist’s inspection of the product, Harrington Hoists, Inc. agrees, at its discretion, either to replace (not including installation) or repair the part or product free of charge and deliver said item F.O.B. Harrington Hoists, Inc. place of business to customer.

Customer must obtain a Return Goods Authorization as directed by Harrington or Harrington’s published repair center prior to shipping product for warranty evaluation. An explanation of the complaint must accompany the product. Product must be returned freight prepaid. Upon repair, the product will be covered for the remainder of the original warranty period. Replacement parts installed after the original warranty period will only be eligible for replacement (not including installation) for a period of one year from the installation date. If it is determined there is no defect, or that the defect resulted from causes not within the scope of Harrington’s warranty, the customer will be responsible for the costs of returning the product.

Harrington Hoists, Inc. disclaims any and all other warranties of any kind expressed or implied as to the product’s merchantability or fitness for a particular application. Harrington will not be liable for death, injuries to persons or property or for incidental, contingent, special or consequential damages, loss or expense arising in connection with the use or inability whatever, regardless of whether damage, loss or expense results from any act or failure to act by Harrington, whether negligent or willful, or from any other reason.

Notes

9.0 Parts List

When ordering Parts, please provide the Hoist code number and serial number located on the Hoist nameplate (see fig. below).

Reminder: Per sections 1.1 and 3.7.1 to aid in ordering Parts and Product Support, record the Hoist code number and serial number in the space provided on the cover of this manual.

Electric Wire Rope Hoist RH Series			
Code	24L1.M	Capacity T	7.5
Speed ft/min	16-5	Lift ft	23 IP 55
ASME Duty Class	H3	E.D. %	17/8
Serial No.	041502/003	Product of Italy	
		HARRINGTON HOIST, INC. 401 WEST END AVENUE MANHEIM, PA. 17545 800.233.3010	
RH Advantage Series Nameplate			

The parts list is arranged into the following sections:

Section	Page
9.1 Hoist Parts	54
9.2 Trolley Parts	58
9.3 Electric Parts	60

10.1 Hoist Parts

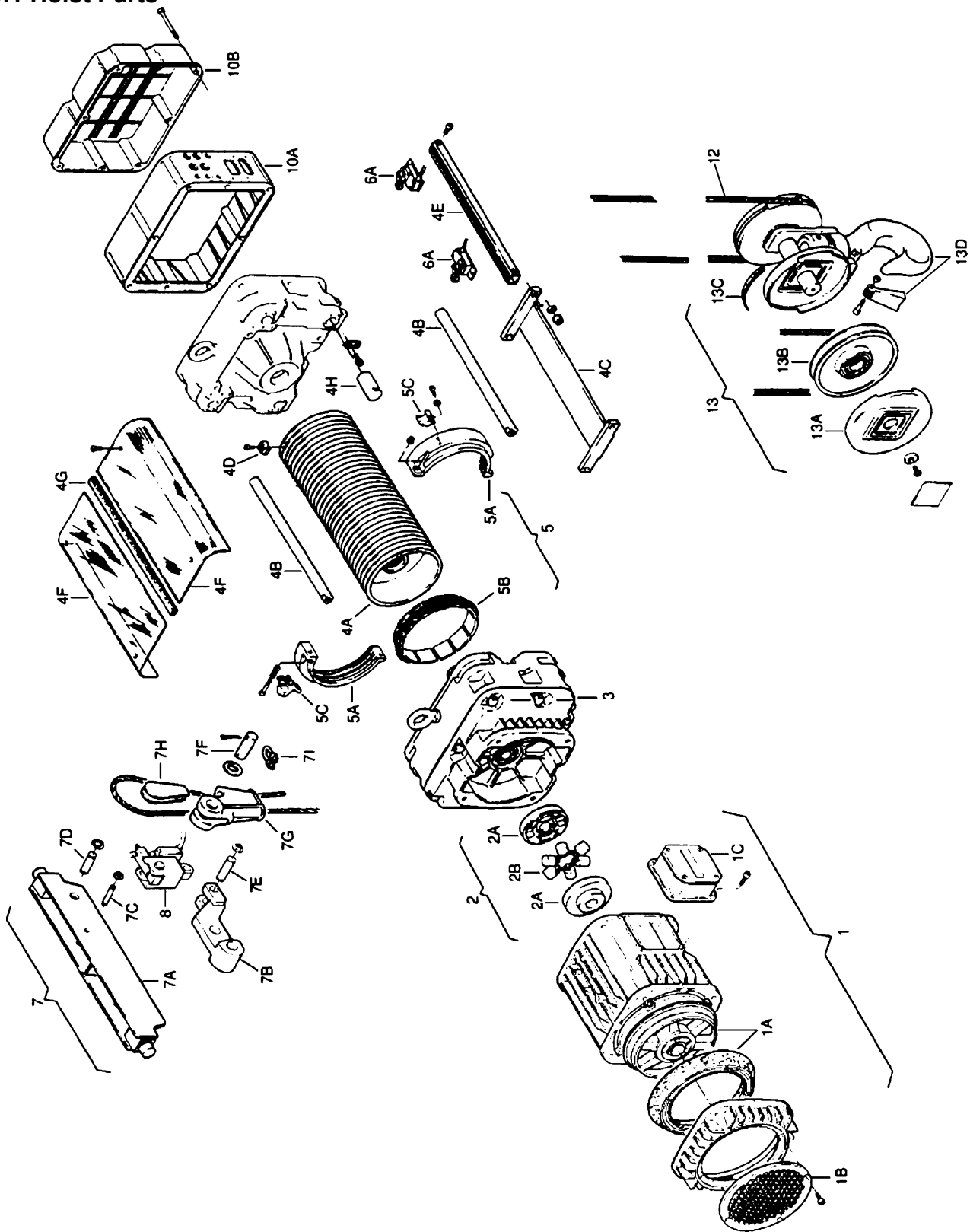

Figure 10-1 Hoist Parts

RH ADVANTAGE HOIST PARTS LIST															
Fig. No.	Part Name	Parts Per Hoist	RH05U23D4G2W-A	RH05U23D4G4W-A	RH05U33D4G2W-A	RH05U33D4G4W-A	RH08U23D3G2W-A	RH08U23D3G4W-A	RH08U33D3G2W-A	RH08U33D3G4W-A	RH10U23D4L2W-A	RH10U23D4L4W-A	RH10U33D4L2W-A	RH10U33D4L4W-A	
1	hoist motor – 2 speed, 230V	1	M71ER50H50								DRH3H0L22				
	hoist motor – 2 speed, 460V	1	M71MR50H50								M81MR50H50				
	1A brake shoe + brake lining	1	DRH250373								DRH350375				
	1B fan cover	1	DRH150395								DRH350395				
	1C connection module	1	DRH1A0MC0								DRH3A0MC0				
2	axial joint	1	DRH1A0GA0								DRH3A0GA0				
	2A half joint	1	DRH110230								DRH310230				
	2B rollers assembly	1	DRH110410								DRH310410				
3	reducer	1	DRH2A0RL0								DRH3A0RL0				
4	rope drum cover – 23 ft. lift	1	DRH2A0PN0								DRH3A0PN0				
	rope drum cover – 33 ft. lift	1	DRH2A0PL0								DRH3A0PL0				
	4A	rope drum – 23 ft. lift	1	DRH210130								DRH310130			
		rope drum – 33 ft. lift	1	DRH210150								DRH310150			
	4B	spacer – 23 ft. lift	2	DRH260190								DRH360190			
		spacer – 33 ft. lift	2	DRH260210								DRH360210			
	4C	staybolt – 23 ft. lift	1	DRH210090								DRH310090			
		staybolt – 33 ft. lift	1	DRH210110								DRH310110			
	4D	rope clamp with bolt	4	DMF160060								DMF360060			
	4E	limit switch cover – 23 ft. lift	1	DRH270240								DRH370240			
		limit switch cover – 33 ft. lift	1	DRH270260								DRH370260			
	4F	dust cover angle – 23 ft. lift	2	DRH260220*								DRH360220*			
		dust cover angle – 33 ft. lift	2	DRH260240*								DRH360240*			
4G	"H" gasket	1	E2200H000*												
4H	suspension pivot	4	DRH260270								DRH360270				
5	rope guide	1	DRH2A0GH0								DRH3A0GH0				
	5A ring	1	DRH260140								DRH360140				
	5B rope press assembly	1	DRH210430								DRH310430				
	5C limit switch actuator	2	DRH260430								DRH360430				
	6A	limit switches	2	E600FLR00											

*Optional Equipment

10.1 Hoist Parts

RH ADVANTAGE HOIST PARTS LIST														
Fig. No.	Part Name	Parts Per Hoist	RH05U23D4G2W-A	RH05U23D4G4W-A	RH05U33D4G2W-A	RH05U33D4G4W-A	RH08U23D3G2W-A	RH08U23D3G4W-A	RH08U33D3G2W-A	RH08U33D3G4W-A	RH10U23D4L2W-A	RH10U23D4L4W-A	RH10U33D4L2W-A	RH10U33D4L4W-A
7	anchorage cross head assy, 23 ft. lift	1	DRH2A0CN2								DRH3A0CN1			
	anchorage cross head assy, 33 ft. lift	1	DRH2A0CL2								DRH3A0CL1			
7A	anchorage cross head, 23 ft. lift	1	DRH210062								DRH310061			
	anchorage cross head, 23 ft. lift	1	DRH210082								DRH310081			
7B	lever	1	DRH270195								DRH370195			
7C	limiter pivot	1	DRH270210								DRH370211			
7D	lever pivot	1	DRH270200								DRH370201			
7E	staybolt pivot	1	DRH170180											
7F	terminal pivot	1	DRH270300								DRH370300			
7G	terminal	1	DRH270150								DRH370150			
7H	terminal wedge	1	DRH270160								DRH370160			
7I	wire rope clamp	1	D65000F08								D65000F13			
8	lever support	1	DRH170220								DRH370220			
	load limiter		DRH1A0C20*				DRH1A0C00				DRH3A0C20*			
10A	electrical frame	1	DRH210940								60854			
10B	cover	1	DRH210950								DRH360850			
12	rope – 23 ft. lift	1	DRH270540				DRH270570				DRH370540			
	rope – 33 ft. lift	1	DRH270560				DRH270580				DRH370560			
13	4 falls hook block	1	DRH2A0B40								DRH3A0B41			
13A	hook side cheek	4	DMF150015								DRH350010			
13B	hook pulley assembly	2	DRH210120								DRH310120			
13C	side cheek gasket	6	DMF150005								DRH350005			
13D	safety latch	1	DRH2A0MOS								3CR750MOS			

*Optional Equipment

This Page Intentionally Left Blank

10.2 Trolley Parts

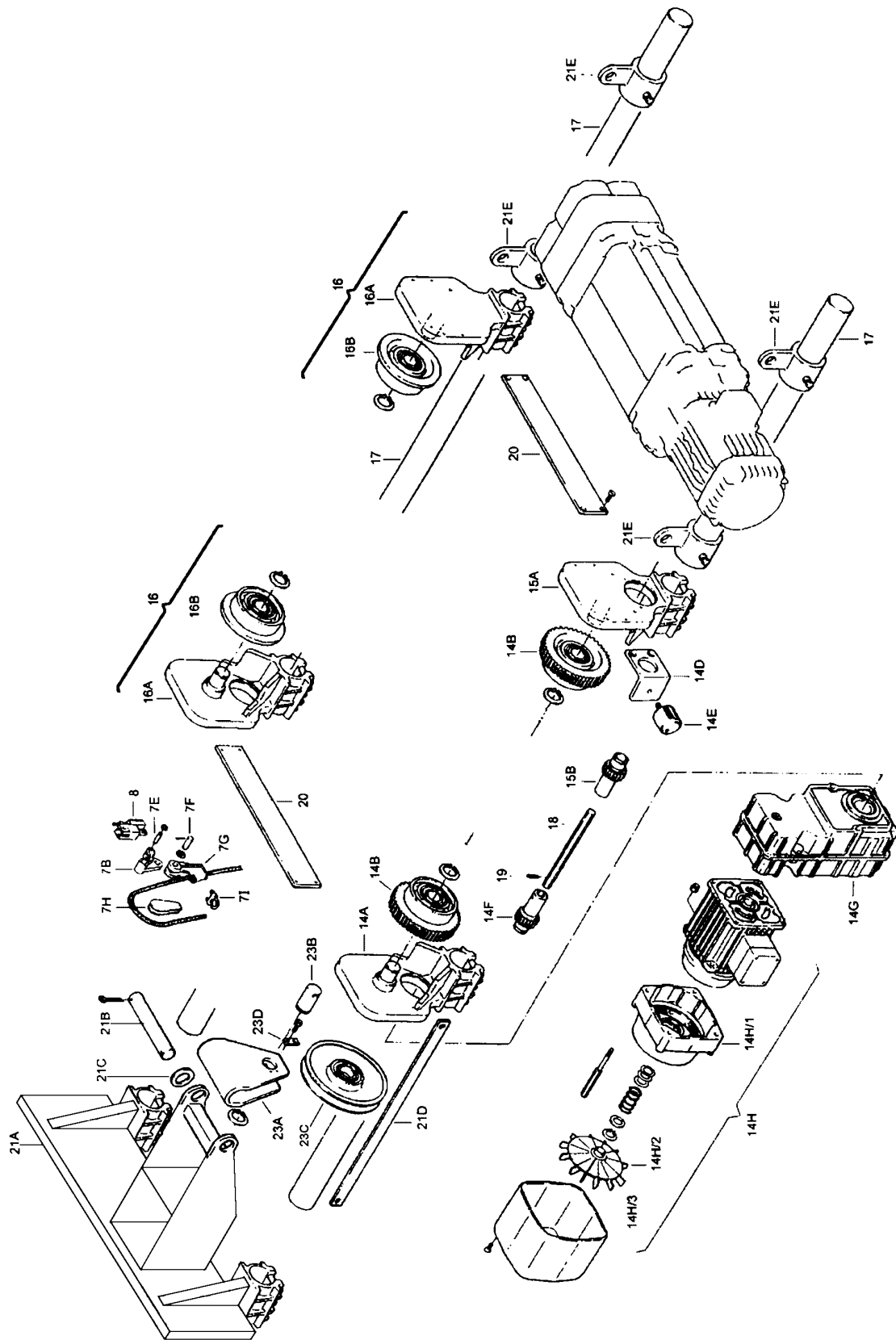

Figure 10-2 Trolley Parts

10.2 Trolley Parts

RH ADVANTAGE TROLLEY PARTS LIST														
Fig. No.	Part Name	Parts Per Trolley	RH05U23D4G2W-A	RH05U23D4G4W-A	RH05U33D4G2W-A	RH05U33D4G4W-A	RH08U23D3G2W-A	RH08U23D3G4W-A	RH08U33D3G2W-A	RH08U33D3G4W-A	RH10U23D4L2W-A	RH10U23D4L4W-A	RH10U33D4L2W-A	RH10U33D4L4W-A
14A	drive plate	1	DST210065								DST310065			
14B	drive wheel assembly	2	DST210080								DST310080			
14D	buffer plate	4	DST250251								DST350251			
14E	buffer	4	DST150240								DST350240			
14F	drive sprocket	1	DST250105								DST350100			
14G	reducer	1	DST1A0R20								DST3A0R20			
14H	trolley motor – 2 speed, 230V	1	DGR1H03L0								DGR2H03L0			
14H	trolley motor – 2 speed, 460V	1	DGR1H03M0								DGR2H03M0			
14H1	motor cover	1	DGR120220								DGR220220			
14H2	fan	1	EVMEC0715								EVMEC0805			
14H3	fan cover	1	DGR160450								DGR260450			
15	drive plate assembly	1	DST2B0E10								DST3B0E10			
15A	drive plate	1	DST210065								DST310065			
15B	cog wheel	1	DST250110								DST350110			
16	idle plate assembly	2	DST2B0E20								DST3B0E20			
16A	idler plate	2	DST210075								DST310075			
16B	idle wheel assembly	2	DST210090								DST310090			
17	connecting bar	2	DST250585								DST350585			
18	transmission bar	1	DST150340								DST350340			
19	roll pin	1	D08004030											
20	connection plate, 23 ft. lift	2	DST250265								DST350265			
20	connection plate, 33 ft. lift	2	DST250285								DST350285			
21A	balance weight, 23 ft. lift	1	DST210105								DST310105			
21A	balance weight, 33 ft. lift	1	DST210125								DST310125			
21B	transverse pivot pin	1	DST250520								DST350520			
21C	washer	2	DST250530								DST350530			
21D	balance weight spacer	2	DST250565								DST350565			
21E	hoist support	4	DST250620								DST350620			
23	pulley assembly	1	DST2A0DR0								DST3A0DR0			
23A	pulley transverse	1	DST250510								DST350510			
23B	pulley pivot	1	DST250550								DST350550			
23C	pulley	1	DRH210120								DRH310120			
23D	pivot stop	1	DMF350260											

10.3 Electrical Parts

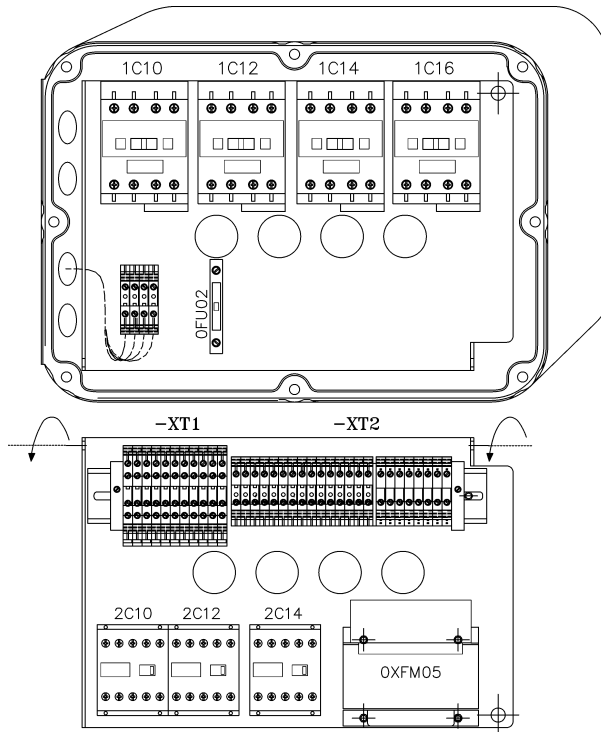

Figure 10-3 5T and 7½T Electrical Components

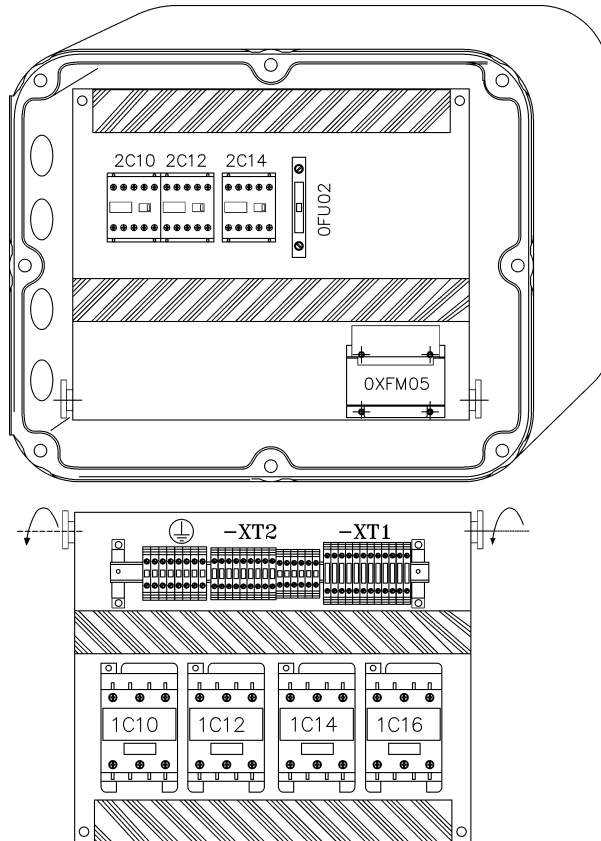

Figure 10-4 10T Electrical Components

10.3 Electrical Parts

RH ADVANTAGE ELECTRICAL COMPONENTS PARTS LIST														
POS.	DESCRIPTION	Parts Per Hoist	RH05U23D4G2W-A	RH05U23D4G4W-A	RH05U33D4G2W-A	RH05U33D4G4W-A	RH08U23D3G2W-A	RH08U23D3G4W-A	RH08U33D3G2W-A	RH08U33D3G4W-A	RH10U23D4L2W-A	RH10U23D4L4W-A	RH10U33D4L2W-A	RH10U33D4L4W-A
			1C10	lift/lower rev.contactor, 230V	1	E6C1D403F				E6C1D633F				
1C12	lift/lower rev.contactor, 230V	1	E6C1D403F				E6C1D633F							
1C14	slow/fast contactor, 230V	1	E6C1D403F				E6C1D633F							
1C16	slow/fast contactor, 230V	1	E6C1D403F				E6C1D633F							
2C10	right/left contactor, 230V	1	EC2K0901F											
2C12	right/left contactor, 230V	1	EC2K0901F											
2C14	slow/fast contactor, 230V	1	EC1K0908F											
0XFM05	transformer, 230V	1	E05160M30											
0FU02	fus.sec.1TC	1	9006272											

RH ADVANTAGE ELECTRICAL COMPONENTS PARTS LIST														
POS.	DESCRIPTION	Parts Per Hoist	RH05U23D4G2W-A	RH05U23D4G4W-A	RH05U33D4G2W-A	RH05U33D4G4W-A	RH08U23D3G2W-A	RH08U23D3G4W-A	RH08U33D3G2W-A	RH08U33D3G4W-A	RH10U23D4L2W-A	RH10U23D4L4W-A	RH10U33D4L2W-A	RH10U33D4L4W-A
			1C10	lift/lower rev.contactor, 460V	1	EC2D2501F				E6C1D403F				
1C12	lift/lower rev.contactor, 460V	1	EC2D2501F				E6C1D403F							
1C14	slow/fast contactor, 460V	1	E6C1D258F				E6C1D403F							
1C16	slow/fast contactor, 460V	1	E6C1D258F				E6C1D403F							
2C10	right/left contactor, 460V	1	EC2K0901F											
2C12	right/left contactor, 460V	1	EC2K0901F											
2C14	slow/fast contactor, 460V	1	EC1K0908F											
0XFM05	transformer, 460V	1	E05063M10				E05160M10							
0FU02	fus.sec.1TC	1	9006272											

Notes

Notes



Harrington Hoists, Inc.
401 West End Avenue
Manheim, PA 17545

www.harringtonhoists.com

Toll Free: 800-233-3010
Phone: 717-665-2000
Fax: 717-665-2861

© HARRINGTON HOISTS, INC.
ALL RIGHTS RESERVED

RHAOM-ENG