
OWNER'S MANUAL

MANUAL CHAIN HOIST CF SERIES

MODEL CF4

1/2 Ton through 5 Ton Capacity

Code, Lot and Serial Number

WARNING

This equipment should not be installed, operated or maintained by any person who has not read and understood all the contents of this manual. Failure to read and comply with the contents of this manual can result in serious bodily injury or death, and/or property damage.

HARRINGTON
A **KITO** GROUP COMPANY



Table of Contents

Section	Page Number
1.0 Important Information and Warnings	4
1.1 Terms and Summary	
1.2 Warning Tags and Labels	
2.0 Technical Information.....	7
2.1 Specifications	
2.2 Dimensions	
2.3 Optional Equipment	
3.0 Preoperational Procedures	11
3.1 Chain	
3.2 Attachment Points	
3.3 Mounting the Hoist	
3.4 Preoperational Checks and Trial Operation	
4.0 Operation	13
4.1 Introduction	
4.2 Shall's and Shall Not's for Operation	
4.3 Operation	
5.0 Inspection	16
5.1 General	
5.2 Inspection Classification	
5.3 Preoperational Inspection	
5.4 Frequent Inspection	
5.5 Periodic Inspection	
5.6 Occasionally Used Hoists	
5.7 Inspection Records	
5.8 Inspection Methods and Criteria	

Section**Page Number**

6.0	Maintenance & Handling	26
6.1	Lubrication	
6.2	Disassembly, Assembly and Adjustment	
6.3	Hoist Disassembly	
6.4	Hoist Assembly	
6.5	Chaining	
6.6	Storage	
6.7	Outdoor Installation	
7.0	Troubleshooting	37
8.0	Warranty	40
9.0	Parts List	42

1.0 Important Information and Warnings

1.1 Terms and Summary

This manual provides important information for personnel involved with the installation, operation and maintenance of this product. Although you may be familiar with this or similar equipment, it is strongly recommended that you read this manual before installing, operating, or maintaining the product.

Danger, Warning, Caution, and Notice

Throughout this manual there are steps and procedures that can present hazardous situations. The following signal words are used to identify the degree or level of hazard seriousness.

⚠ DANGER Danger indicates an imminently hazardous situation which, if not avoided, **will** result in **death or serious injury**, and property damage.

⚠ WARNING Warning indicates an imminently hazardous situation which, if not avoided, **could** result in **death or serious injury**, and property damage.

⚠ CAUTION Caution indicates a potentially hazardous situation which, if not avoided, **may** result **minor or moderate injury** or property damage.

NOTICE Notice is used to notify people of installation, operation, or maintenance information which is important but not directly hazard-related.

⚠ CAUTION

These general instructions deal with the normal installation, operation, and maintenance situations encountered with the equipment described herein. The instructions should not be interpreted to anticipate every possible contingency or to anticipate the final system, crane, or configuration that uses this equipment. For systems using the equipment covered by this manual, the supplier and owner of the system are responsible for the system's compliance with all applicable industry standards, and with all applicable federal, state, and local regulations/codes.

This manual includes instructions and parts information for a variety of hoist types. Therefore, all instructions and parts information may not apply to any one type or size of specific hoist. Disregard those portions of the instructions that do not apply.

Record your hoist's Code, Lot and Serial Number (see Section 9) on the front cover of this manual for identification and future reference to avoid referring to the wrong manual for information or instructions on installation, operation, inspection, maintenance, or parts.

Use only Harrington authorized replacement parts in the service and maintenance of this hoist.

WARNING

Equipment described herein is not designed for and **MUST NOT** be used for lifting, supporting, or transporting people, or for lifting or supporting loads over people.

Equipment described herein should not be used in conjunction with other equipment unless necessary and/or required safety devices applicable to the system, crane, or application are installed by the system designer, system manufacturer, crane manufacturer, installer, or user.

Modifications to upgrade, rerate, or otherwise alter this equipment shall be authorized only by the original equipment manufacturer.

If a below-the-hook lifting device or sling is used with a hoist, refer to ANSI/ASME B30.9, "Slings" or ANSI/ASME B30.20, "Below-the-Hook Lifting Devices".

Hoists used to handle hot molten material may require additional equipment or devices. Refer to ASTM E2349, "Standard Practice for Safety Requirements in Metal Casting Operations: Sand Preparation, Molding, and Core Making; Melting and Pouring; and Cleaning and Finishing".

Failure to read and comply with any one of the limitations noted herein can result in serious bodily injury or death, and/or property damage.

NOTICE

It is the responsibility of the owner/user to install, inspect, test, maintain, and operate a hoist in accordance with ANSI/ASME B30.16, "Overhead Underhung and Stationary Hoists" and OSHA Regulations. If the hoist is installed as part of a total lifting system, such as an overhead crane or monorail, it is also the responsibility of the owner/user to comply with the applicable ANSI/ASME B30 volume that addresses that type of equipment.

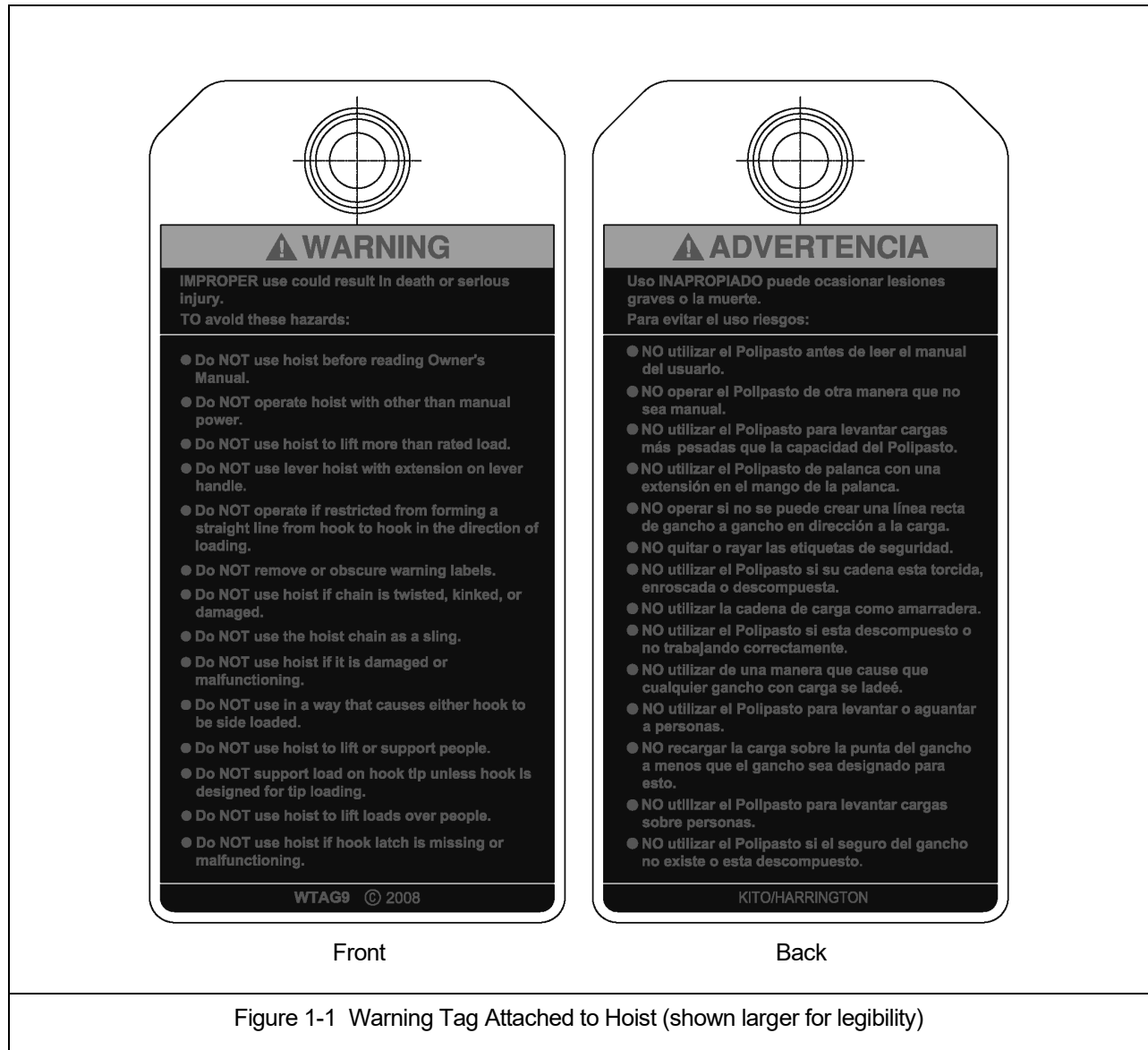
It is the responsibility of the owner/user to have all personnel that will install, inspect, test, maintain, and operate a hoist read the contents of this manual and applicable portions of ANSI/ASME B30.16, "Overhead Underhung and Stationary Hoists" and OSHA Regulations.

If the hoist owner/user requires additional information, or if any information in the manual is not clear, contact Harrington or the distributor of the hoist. Do not install, inspect, test, maintain, or operate this hoist unless this information is fully understood.

A regular schedule of inspection of the hoist in accordance with the requirements of ANSI/ASME B30.16 should be established and records maintained.

1.2 Warning Tags and Labels

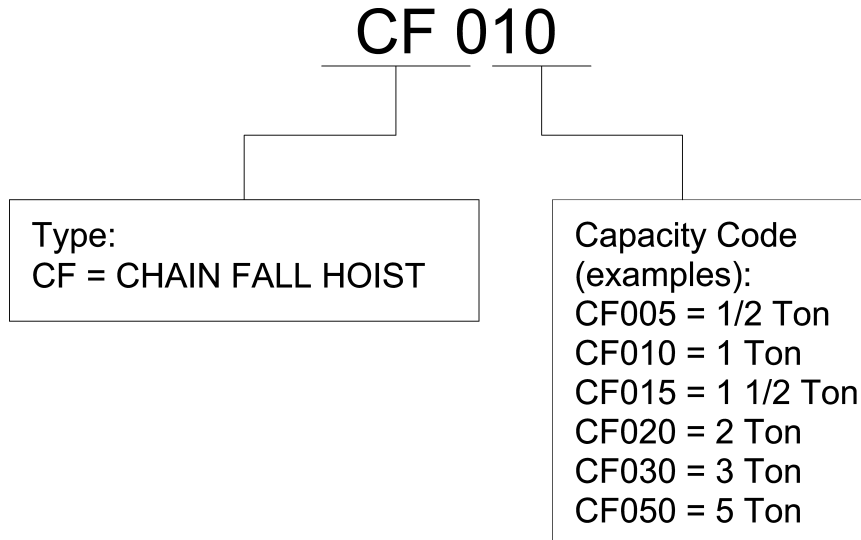
The warning tag illustrated below in Figure 1-1 is supplied with each hoist shipped from the factory. If the tag is not attached to your hoist's hand chain with a chain stopper link, order a tag from your dealer and install it. Read and obey all warnings attached to this hoist. Tag is not shown actual size.



2.0 Technical Information

2.1 Specifications

2.1.1 Product Code



2.1.2 Operating Conditions and Environment

Temperature range: -4° to +140°F (-20° to +60°C)

Humidity: 100% or less (Not an Underwater Device)

Cap. (Tons)	Product Code	Std. Lift (ft)	Pull to Lift Load (lbs)	Load Chain Diameter (mm) x Chain Fall Lines	Overhaul Ratio	Net Weight (lbs)	Shipping Weight Approx. (lbs)	Weight for Additional One Foot of Lift (lbs)
½	CF005	10	60	5.0 x 1	19	24	26	1.0
1	CF010		72	6.3 x 1	31	29	31	1.2
1½	CF015		84	7.1 x 1	41	40	42	1.4
2	CF020		80	6.3 x 2	63	47	49	1.8
3	CF030		92	7.1 x 2	81	62	66	2.2
5	CF050		92	7.1 x 3	134	82	86	2.9

*NOTE: Any lift of chain is available on request. Simply specify the length of chain desired when ordering. Because Harrington chains are specially heat treated, only authentic Harrington chains should be used on your hoist. **NEVER** attempt to lengthen the chain by attaching additional chain links to it or by any other means.

2.2 Dimensions

Table 2-2 Hoist Dimensions								
Cap. (Tons)	Product Code	Headroom c (in)	a (in)	b (in)	d (ft)	e (in)	f (in)	g (in)
1/2	CF005	12.8	5.4	5.9	10	2.0	2.4	1.1
1	CF010	14.6	5.8	6.9	10	2.3	2.9	1.1
1 1/2	CF015	17.3	6.0	8.0	10	2.4	3.4	1.3
2	CF020	20.1	5.8	8.0	10	2.3	2.3	1.4
3	CF030	23.2	6.0	9.4	10	2.4	2.7	1.7
5	CF050	24.4	6.0	13.5	10	2.4	4.5	1.8

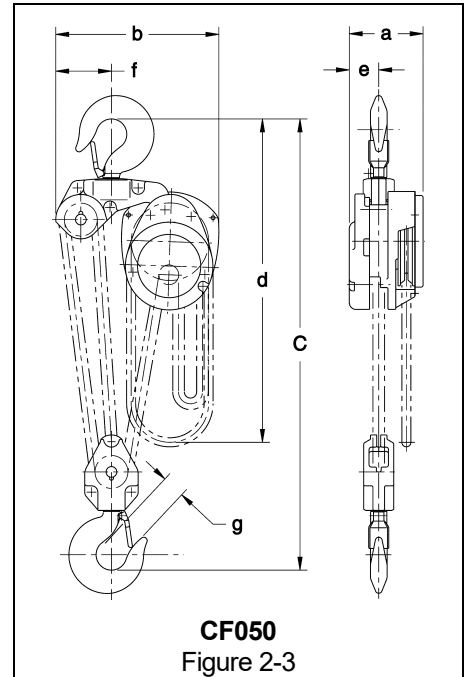
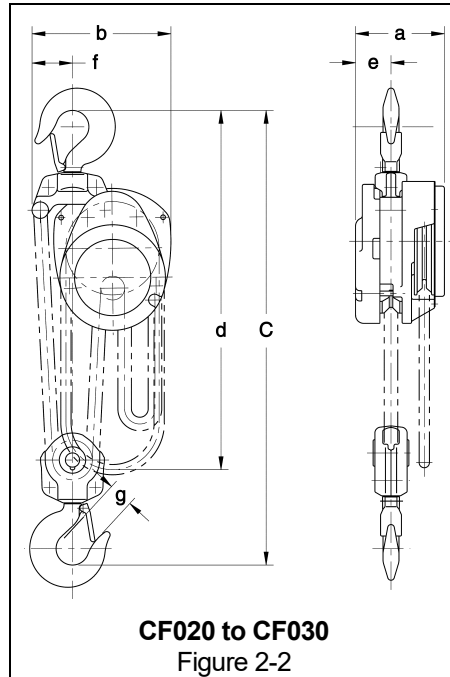
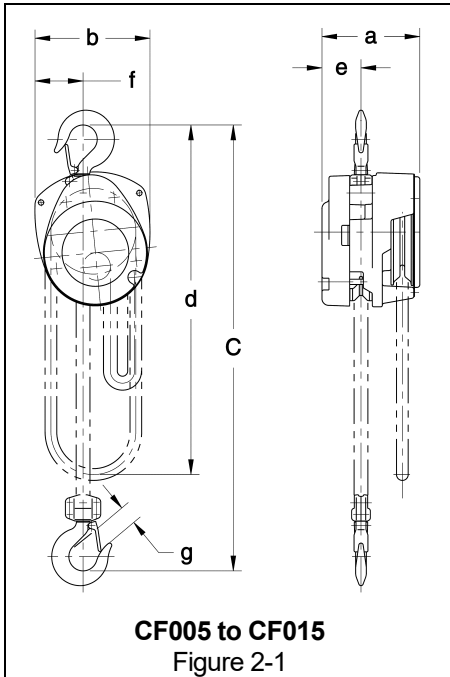
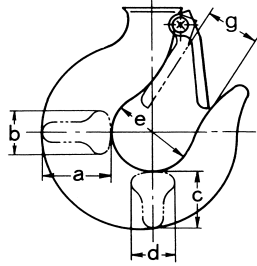


Table 2-3 Hook Dimension*



T = Top Hook
 B = Bottom Hook
 Units = inch

Cap. (Tons)	Product Code	Hook	a	b	c	d	e	g
1/2	CF005	T & B	0.8	0.5	0.7	0.5	1.4	1.1
1	CF010		1.0	0.6	0.9	0.6	1.7	1.1
1½	CF015		1.2	0.8	1.0	0.8	1.9	1.3
2	CF020		1.4	0.9	1.2	0.9	2.0	1.4
3	CF030		1.8	1.1	1.5	1.1	2.2	1.7
5	CF050		2.2	1.4	1.9	1.4	2.5	1.8

*Refer to Section 5.7 for inspection dimensions and limits.

2.3 Optional Equipment

2.3.1 Optional Latch Lock Hooks

- The Bullard® hook has a conventional hook shape with a special, heavy-duty, rotating, spring-loaded, locking latch. The latch remains locked until it is released by the operator.
- The SmartLok™ hook is a special design hook where the latch remains fixed and the hook swings to unlock. The hook cannot be opened while a load is applied. *(Note: this type of hook was previously offered as a Shur-Loc®, but was replaced in 2022)*
- Installation of these hooks may change the headroom.
- See Section 9.3, Parts List for a complete Latch Lock Hook part listing.
- See Table 6-3 for yoke nut torque specifications.

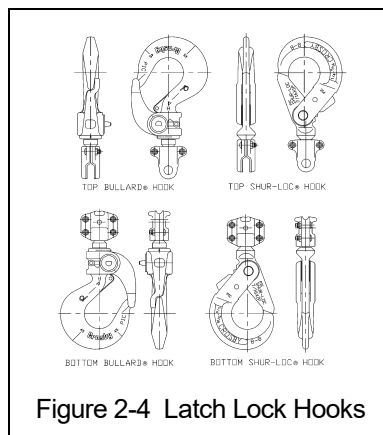
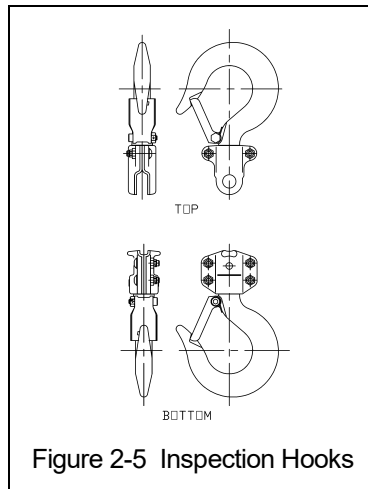


Figure 2-4 Latch Lock Hooks

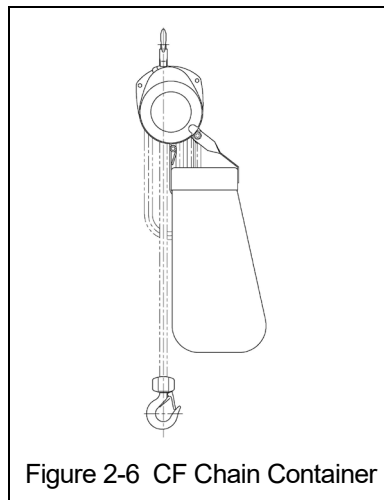
2.3.2 Optional Inspection Hooks

- The Inspection Hook is designed to facilitate the inspection of the internal surfaces of the hook yoke and shank portion of the hook itself. The Inspection Hook is suitable for applications where inspection of the internal parts of the hook set is required. The inspection hook uses the standard Harrington hook set and is assembled with high-strength locking fasteners instead of rivets. Inspection hooks are available in top and bottom versions. Refer to Figure 2-5.
- Disassembly and re-assembly involves removal and reinstallation of the yoke fasteners of the Inspection Hook Set Assembly followed by testing of the hoist prior to returning it to service.
- The Inspection Hook is available for CF005 through CF015 hoists.
- See Section 9.3, Parts List for a complete Inspection Hook part listing.
- See Table 6-3 for yoke nut torque specifications.



2.3.3 Optional Chain Containers

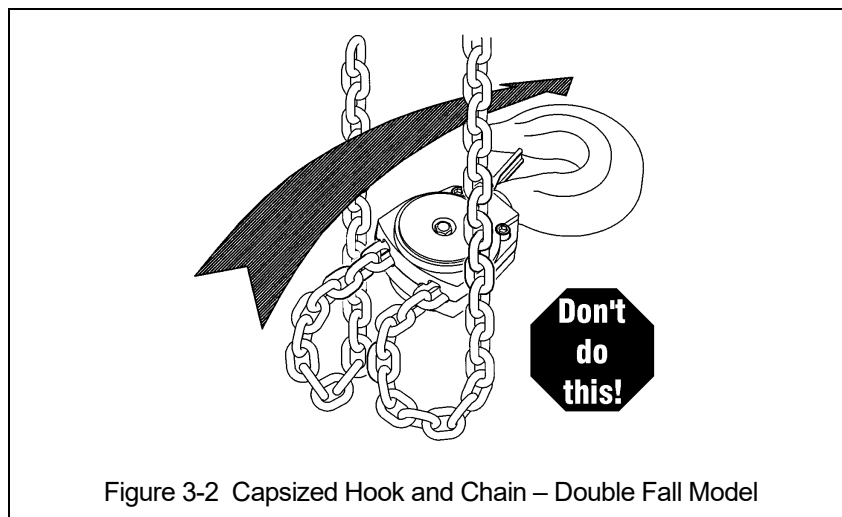
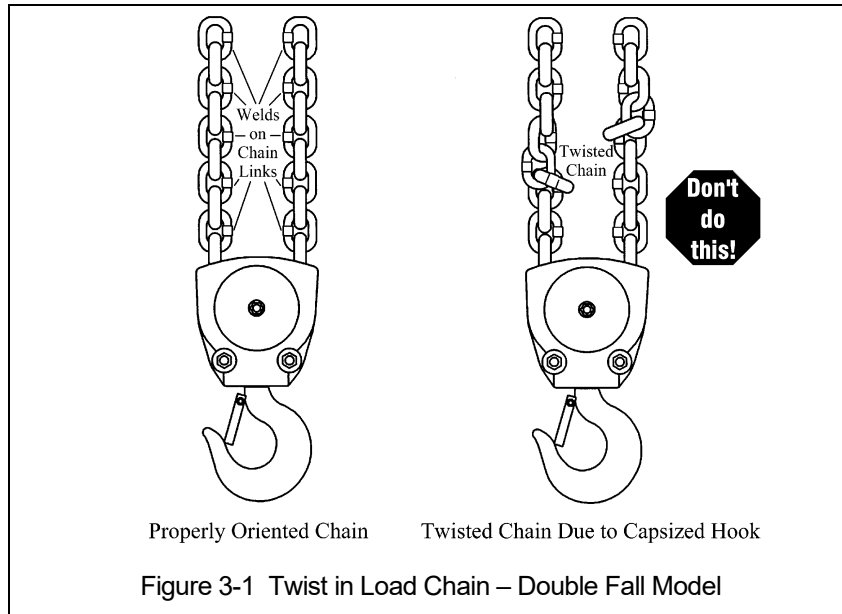
- Chain containers are sized based on the capacity and lift of the hoist. The containers are constructed from vinyl coated canvas with a steel frame on top. The containers are prepared differently depending on the hoist model. See Section 9.4, "Optional Chain Container".



3.0 Preoperational Procedures

3.1 Chain

- 3.1.1 **⚠️ WARNING** Verify that the load chain is not twisted or tangled prior to operating the hoist. Make sure the bottom hook on the 2 Ton (CF020) through the 5 Ton (CF050) multiple fall hoists is not capsized. See Figures 3-1 and 3-2. Correct all chain irregularities before conducting the first hoist operation.



3.2 Attachment Points

3.2.1 **⚠️ WARNING** Prior to attaching the hoist ensure that all attachment points, suspension components and supporting structure are adequate to support the hoist and its load. If necessary consult a professional that is qualified to evaluate the adequacy of the suspension location and its supporting structure.

3.2.2 **NOTICE** See Section 6.7 for outdoor installation considerations.

3.3 Mounting the Hoist

3.3.1 Hook Mounted to a Fixed Location - Attach the hoist's top hook to the fixed suspension point.

3.3.2 **⚠️ WARNING** Ensure that the fixed suspension point rests on the center of the hook's saddle and that the hook's latch is engaged.

3.4 Preoperational Checks and Trial Operation

3.4.1 **⚠️ WARNING** Confirm the adequacy of the rated capacity for all slings, chains, wire ropes and all other lifting attachments before use. Inspect all load suspension members for damage prior to use and replace or repair all damaged parts.

3.4.2 **⚠️ WARNING** Verify and correct all chain irregularities prior to operating the hoist. Refer to Section 3.1.

3.4.3 Measure and record the "k" dimension of all hooks on hoist. See Table 5-5 under Section 5, "Inspection".

3.4.4 Record the hoist's Code, Lot and Serial Number (from the nameplate on the hoist; see Section 9) in the space provided on the cover of this manual.

3.4.5 Ensure that the hoist is properly installed to a fixed point.

3.4.6 Ensure that all nuts, bolts and split pins (cotter pins) are sufficiently fastened.

3.4.7 Confirm proper operation.

- Before operating read and become familiar with Section 4 - Operation.
- Before operating ensure that the hoist meets the Inspection, Testing and Maintenance requirements of ANSI/ASME B30.16.
- Before operating ensure that nothing will interfere with the full range of the hoist's operation.

4.0 Operation

4.1 Introduction

DANGER

DO NOT WALK UNDER A SUSPENDED LOAD

WARNING

HOIST OPERATORS SHALL BE REQUIRED TO READ THE OPERATION SECTION OF THIS MANUAL, THE WARNINGS CONTAINED IN THIS MANUAL, INSTRUCTION AND WARNING LABELS ON THE HOIST OR LIFTING SYSTEM, AND THE OPERATION SECTIONS OF ANSI/ASME B30.16 and ANSI/ASME B30.10. THE OPERATOR SHALL ALSO BE REQUIRED TO BE FAMILIAR WITH THE HOIST AND HOIST CONTROLS BEFORE BEING AUTHORIZED TO OPERATE THE HOIST OR LIFTING SYSTEM.

HOIST OPERATORS SHOULD BE TRAINED IN PROPER RIGGING PROCEDURES FOR THE ATTACHMENT OF LOADS TO THE HOIST HOOK.

HOIST OPERATORS SHOULD BE TRAINED TO BE AWARE OF POTENTIAL MALFUNCTIONS OF THE EQUIPMENT THAT REQUIRE ADJUSTMENT OR REPAIR, AND TO BE INSTRUCTED TO STOP OPERATION IF SUCH MALFUNCTIONS OCCUR, AND TO IMMEDIATELY ADVISE THEIR SUPERVISOR SO CORRECTIVE ACTION CAN BE TAKEN.

HOIST OPERATORS SHOULD HAVE NORMAL DEPTH PERCEPTION, FIELD OF VISION, REACTION TIME, MANUAL DEXTERITY, AND COORDINATION.

HOIST OPERATORS SHOULD **NOT** HAVE A HISTORY OF OR BE PRONE TO SEIZURES, LOSS OF PHYSICAL CONTROL, PHYSICAL DEFECTS, OR EMOTIONAL INSTABILITY THAT COULD RESULT IN ACTIONS OF THE OPERATOR BEING A HAZARD TO THE OPERATOR OR TO OTHERS.

HOIST OPERATORS SHOULD **NOT** OPERATE A HOIST OR LIFTING SYSTEM WHEN UNDER THE INFLUENCE OF ALCOHOL, DRUGS, OR MEDICATION.

NOTICE

- Read ANSI/ASME B30.16 and ANSI/ASME B30.10.
- Read the hoist manufacturer's Operating and Maintenance Instructions.
- Read all labels attached to equipment.

The operation of a hoist involves more than activating the hoist's controls. Per the ANSI/ASME B30 standard, the use of a hoist is subject to certain hazards that cannot be mitigated by engineered features, but only by the exercise of intelligence, care, common sense, and experience in anticipating the effects and results of activating the hoist's controls. Use this guidance in conjunction with other warnings, cautions, and notices in this manual to govern the operation and use of your hoist.

4.2 Shall's and Shall Not's for Operation

WARNING

Improper operation of a hoist can create a potentially hazardous situation which, if not avoided, could result in death or serious injury, and substantial property damage. To avoid such a potentially hazardous situation **THE OPERATOR SHALL:**

- **NOT** lift more than rated load for the hoist.
- **NOT** use damaged hoist or hoist that is not working properly.
- **NOT** use hoist with twisted, kinked, damaged, or worn chain.
- **NOT** use hoist if the bottom hook is capsized (multiple fall hoists - see Section 3.1).
- **NOT** use the hoist to lift, support, or transport people.
- **NOT** lift loads over people.
- **NOT** apply load unless load chain is properly seated in the load sheave (and idle sheave for hoist with multiple chain falls).
- **NOT** use the hoist in such a way that could result in shock or impact loads being applied to the hoist.
- **NOT** attempt to lengthen the load chain or repair damaged load chain.
- **NOT** operate hoist when it is restricted from forming a straight line from hook to hook in the direction of loading.
- **NOT** use load chain as a sling or wrap load chain around load.
- **NOT** apply load if binding prevents equal loading on all load-supporting chains.
- **NOT** operate beyond the limits of the load chain travel.
- **NOT** support load on hook tip unless hook is designed for tip loading.
- **NOT** use in a way that causes either hook to be side-loaded.
- **NOT** leave load supported by the hoist unattended unless specific precautions have been taken.
- **NOT** allow the chain, or hook to be used as an electrical or welding ground.
- **NOT** allow the chain, or hook to be touched by a live welding electrode.
- **NOT** remove or obscure the warnings on the hoist.
- **NOT** operate a hoist on which the safety placards or decals are missing or illegible.
- Be familiar with operating controls, procedures, and warnings.
- Make sure the unit is securely attached to a suitable support before applying load.
- Make sure load slings or other approved single attachments are properly sized, rigged, and seated in the hook saddle.
- Take up slack carefully - make sure load is balanced and load-holding action is secure before continuing.
- Make sure all persons stay clear of the supported load.
- Protect the hoist's load chain from weld splatter or other damaging contaminants.
- Report Malfunctions or unusual performances (including unusual noises) of the hoist and remove the hoist from service until the malfunction or unusual performance is resolved.
- Warn personnel before lifting or moving a load.
- Warn personnel of an approaching load.

CAUTION

Improper operation of a hoist can create a potentially hazardous situation which, if not avoided, could result in minor or moderate injury, or property damage. To avoid such a potentially hazardous situation **THE OPERATOR SHALL:**

- Maintain a firm footing or be otherwise secured when operating the hoist.
- Check brake function by tensioning the hoist prior to each lift operation.
- Use hook latches. Latches are to retain slings, chains, etc. under slack conditions only.
- Make sure the hook latches are closed and not supporting any parts of the load.
- Make sure the load is free to move and will clear all obstructions.
- Avoid swinging the load or hook.
- Make sure hook travel is in the same direction as shown on controls.
- Inspect the hoist regularly, replace damaged or worn parts, and keep appropriate records of maintenance.
- Use the hoist manufacturer's recommended parts when repairing the unit.
- Lubricate load chain per hoist manufacturer's recommendations.
- **NOT** use the hoist load limiting or warning device to measure load.
- **NOT** allow your attention to be diverted from operating the hoist.
- **NOT** allow the hoist to be subjected to sharp contact with other hoists, structures, or objects through misuse.
- **NOT** adjust or repair the hoist unless qualified to perform such adjustments or repair.

4.3 Operation

- 1) Face the hand chain wheel side of the hoist.
- 2) To raise the load, pull hand chain clockwise.
- 3) To lower the load, pull hand chain counterclockwise.

NOTE: The clicking sound of the pawl when a load is being raised indicates normal operation.

5.0 Inspection

5.1 General

5.1.1 The inspection procedure herein is based on ANSI/ASME B30.16. The following definitions are from ANSI/ASME B30.16 and pertain to the inspection procedure below.

- **Designated Person** – a person selected or assigned as being competent to perform the specific duties to which he/she is assigned.
- **Qualified Person** – a person who, by possession of a recognized degree or certificate of professional standing, or who, by extensive knowledge, training, and experience, has successfully demonstrated the ability to solve or resolve problems relating to the subject matter and work.
- **Normal Service** – that distributed service which involves operation with randomly distributed loads within the rated load limit, or uniform loads less than 65% of rated load for not more than 15% of the time.
- **Heavy Service** – that service which involves operation within the rated load limit which exceeds normal service.
- **Severe Service** – that service which involves normal or heavy service with abnormal operating conditions.

5.2 Inspection Classification

5.2.1 Inspection Classification – the inspection procedure for hoists in regular service is divided into three general classifications based upon the intervals at which inspection should be performed. The intervals in turn are dependent upon the nature of the critical components of the hoist and the degree of their exposure to wear, deterioration, or malfunction. The three general classifications are herein designated as PREOPERATIONAL, FREQUENT and PERIODIC, with respective intervals between inspections as defined below.

5.2.2 Initial Inspection – prior to initial use, all new, altered, or modified hoists shall be inspected by a designated person to ensure compliance with the applicable provisions of this manual.

5.2.3 PREOPERATIONAL Inspection – Visual inspection performed before the first use of each shift with records not required.

5.2.4 FREQUENT Inspection – visual examinations by the operator or other designated personnel with intervals per the following criteria:

- Normal service – monthly
- Heavy service – weekly to monthly
- Severe service – daily to weekly
- Special or infrequent service – as recommended by a qualified person before and after each occurrence.

5.2.5 PERIODIC Inspection – visual inspection by a designated person with intervals per the following criteria:

- Normal service – yearly
- Heavy service – semiannually
- Severe service – quarterly
- Special or infrequent service – as recommended by a qualified person before the first such occurrence and as directed by the qualified person for any subsequent occurrences.

5.3 Preoperational Inspection

5.3.1 Visual inspections shall be made before the first use of each shift with records not required.

Table 5-1 Preoperational Inspection
All functional operating mechanisms for proper operation, adjustment, and unusual sounds.
Hoist braking system for proper operation.
Hooks and latches in accordance with ANSI/ASME B30.10, Frequent Inspection (paras. 10-1.10.3 and 10-2.10.3.)
Load chain for severe damage including nicks, gouges, weld spatter, corrosion, or distorted links.
Load chain reeving for compliance with Section 3.1 and 6.5.
Over-travel restraint for proper attachment.
Hoist body for deformation, cracks and /or other damage.
Hoist support or trolley, if used, for damage.

5.4 Frequent Inspection

5.4.1 Inspections should be made on a FREQUENT basis in accordance with Table 5-2, "Frequent Inspection." Included in these FREQUENT Inspections are observations made during operation for any defects or damage that might appear between Periodic Inspections. Evaluation and resolution of the results of FREQUENT Inspections shall be made by a qualified person such that the hoist is maintained in safe working condition.

Table 5-2 Frequent Inspection
All functional operating mechanisms for proper operation, adjustment, and unusual sounds.
Hoist braking system for proper operation
Hooks and latches in accordance with ANSI/ASME B30.10
Hook latch operation
Load chain for severe damage including nicks, gouges, weld spatter, corrosion, or distorted links.
Load chain reeving for compliance with Section 3.1 and 6.5
Hoist support for damage

5.5 Periodic Inspection

5.5.1 Inspections should be made on a PERIODIC basis in accordance with Table 5-3, "Periodic Inspection." Evaluation and resolution of the results of PERIODIC Inspections shall be made by a qualified person such that the hoist is maintained in safe working condition.

5.5.2 For inspections where load suspension parts of the hoist are disassembled, a load test per ANSI/ASME B30.16 must be performed on the hoist after it is re-assembled and prior to its return to service.

Table 5-3 Periodic Inspection
Requirements of frequent inspection.
Evidence of loose bolts, nuts, or rivets.
Evidence of worn, corroded, cracked, or distorted parts such as load blocks, suspension housing, chain attachments, clevises, yokes, suspension bolts, shafts, gears, bearings, pins, rollers and locking and clamping devices.
Evidence of damage to hook retaining nuts or collars and pins, and welds or rivets used to secure the retaining members.
Evidence of damage or excessive wear of load and idler sheaves.
Evidence of worn, glazed or oil contaminated friction disks; worn pawls, cams or ratchet; corroded, stretched, or broken pawl springs in brake mechanism.
Evidence of damage to supporting structure.
Function label on hoist for legibility.
Warning label properly attached to the hoist and legible (see Section 1.2).
Load chain in accordance with Section 5.8
End connection of load chain.

5.6 Occasionally Used Hoists

5.6.1 Hoists that are used infrequently shall be inspected as follows prior to placing in service:

- Hoist Idle More Than 1 Month, Less Than 1 Year: Inspect per FREQUENT Inspection criteria in Section 5.3.
- Hoist Idle More Than 1 Year: Inspect per PERIODIC Inspection criteria in Section 5.5, or as determined by a qualified person.

5.7 Inspection Records

5.7.1 Dated inspection reports and records should be maintained at time intervals corresponding to those that apply for the hoist's PERIODIC interval per Section 5.2.6. These records should be stored where they are available to personnel involved with the inspection, maintenance, or operation of the hoist.

5.7.2 A long range chain inspection program should be established and should include records of examination of chains removed from service so a relationship can be established between visual observation and actual condition of the chain.

5.8 Inspection Methods and Criteria

5.8.1 This section covers the inspection of specific items. The list of items in this section is based on those listed in ANSI/ASME B30.16 for the Frequent and Periodic Inspection.

5.8.2 Frequent Inspection - Not intended to involve disassembly of the hoist. Disassembly for further inspection would be required if only if frequent inspection results so indicate. Disassembly and further inspection should only be performed by a qualified person trained in the disassembly and re-assembly of the hoist.

5.8.3 Periodic Inspection - Disassembly of the hoist is required. Disassembly should only be performed by a qualified person trained in the disassembly and re-assembly of the hoist.

Table 5-4 Hoist Inspection Methods and Criteria			
Item	Method	Discard Limit/Criteria	Action
Functional operating mechanisms.	Visual, Auditory	Mechanisms should be properly adjusted and should not produce unusual sounds when operated. Components should not be deformed, scarred, or show significant wear. Refer to Figures 5-2, 5-3 and 5-4.	Repair or replace as required.
Hooks – Stretch	Measure	The "k" dimension should not be greater than 1.05 times that measured and recorded at the time of purchase (See Section 3.4). If recorded "k" values are not available for hooks when new, use nominal "k" values from Table 5-5.	Replace.
Hooks – Fretting wear	Measure	The "u" and "t" dimensions should not be less than discard value listed in Table 5-5.	Replace.
Hooks – Surface Condition	Visual	Should be free of gouges, deep nicks, dents, weld splatter, and significant corrosion.	Replace.
Hooks – Deformation	Visual	Should be free of twists and deformations. See Figure 5-1.	Replace.
Hooks – Bent Shank or Neck	Visual	Shank and neck portions of hook should be free of deformations.	Replace.
Hooks – Swivel	Visual, Function	Bearing parts and surfaces should not show significant wear, and should be free of dirt, grime, and deformations. Hook should rotate freely with no roughness. See Figure 5-1.	Clean/lubricate, or replace as required.
Hooks – Yoke Assembly	Visual	Should be free of significant rust, weld splatter, nicks, and gouges. Holes should not be elongated, fasteners should not be loose, and there should be no gap between mating parts.	Tighten or replace as required.
Hooks – Idle Sheave and Shaft (Multiple Fall Hoist)	Visual, Function	Pockets of Idle Sheave should be free of significant wear. Idle Sheave surfaces should be free of nicks, gouges, dirt, and grime. Bearing parts and surfaces of Idle Sheave and Axle should not show significant wear. Idle Sheave should rotate freely with no roughness or significant free play.	Clean/lubricate, or replace as required.
Hooks – Hook Latches	Visual, Function	Latch should not be deformed. Attachment of latch to hook should not be loose. Latch spring should not be missing and should not be weak. Latch movement should not be stiff - when depressed and released latch should snap smartly to its closed position.	Replace.
Yoke – Top Pin Hole Deformation	Visual, Measure	The "d" dimension of the top pin hole should not be greater than the discard value listed in Table 5-6.	Replace Hook Set
Top Pin – Deformation	Visual, Measure	The pin should be free of scars or significant deformation. The "d" dimension should not be less than discard value listed in Table 5-7.	Replace
Yoke – Chain Pin Hole Deformation	Measure	The "d" dimension of the chain pin hole should not be greater than the discard value listed in Table 5-6.	Replace Hook Set or yoke.

Table 5-4 Hoist Inspection Methods and Criteria

Item	Method	Discard Limit/Criteria	Action
Chain Pin – Deformation	Visual, Measure	The pin should be free of scars or significant deformation. The “d” dimension should not be less than discard value listed in Table 5-8.	Replace
Load Chain – Pitch and Wire Diameter	Measure	The “P” dimension should not be greater than discard value listed in Table 5-9. The “d” dimension should not be less than discard value listed in Table 5-9.	Replace. Inspect Load Sheave (and Idle Sheave for multiple fall hoists).
Load Chain – Surface Condition	Visual	Should be free of gouges, nicks, dents, weld splatter, and corrosion. Links should not be deformed, and should not show signs of abrasion. Surfaces where links bear on one another should be free of significant wear.	Replace.
Load Chain – Lubrication	Visual, Auditory	Entire surface of each chain link should be coated with lubricant and should be free of dirt and grime. Chain should not emit cracking noise when hoisting a load.	Clean/lubricate (see Section 6.0).
Load Chain – Reeving	Visual	Chain should be reeved properly through Load Sheave. On multiple fall hoists chain should be installed properly and free of twists. Refer to Section 3.1.	Reeve/Install chain properly.
Lifting System – Components	Visual, Function	Components should not be deformed, scarred, or show significant wear.	Replace.
Braking System – Components	Visual	Brake Pawl, Pawl Pin, and Pawl Spring should not be deformed, scarred, or show significant wear. Refer to Figure 5-2 (27, 24, & 26).	Replace.
Brake – Damage to Brake Surface	Visual	Damage due to scratching or gouging by foreign matter. Refer to Figure 5-2 (32, 30, & 33).	Replace.
Braking System – Friction Disc	Visual	The surface of the friction plate should be free of scars, gouges, and wear. Refer to Figure 5-2 (29).	Replace.
Braking System – Friction Plate	Visual, Measure	The surface of the friction plate should be free of grease, oil, scars, gouges and wear and have uniform thickness. The outer thickness should not be thinner than the inner thickness. The thickness should not be less than the discard value listed in Table 5-10.	Replace.
Braking System – Bushing	Measure	The bushing should have uniform thickness. The “t” dimension should not be less than the discard value listed in Table 5-11.	Replace.
Braking System – Bushing	Visual	When slightly heated, the bushing should be so lubricated that lubricant oozes off the surface. Refer to Figure 5-2 (31). Type of oil to be used: ISO VG68 or equivalent.	Soak bushing in machine oil for one day.
Braking System – Ratchet Disc	Measure	The “D” dimension should not be less than the discard value listed in Table 5-12. Refer to Figure 5-2 (30).	Replace.

Table 5-4 Hoist Inspection Methods and Criteria			
Item	Method	Discard Limit/Criteria	Action
Load Sheave	Visual	Pockets of Load Sheave should be clean and free of significant wear. Refer to Figure 5-3 (18).	Replace.
Load Gear	Visual	Teeth have excessive wear or damage. Refer to Figure 5-4 (19).	Replace.
Hand Wheel	Visual	Large wear or deformation on the surface of hand wheel. The hand wheel touches the cover.	Replace.
Housing and Mechanical Components	Visual, Auditory, Function	Hoist components including load blocks, suspension housing, chain attachments, clevises, yokes, suspension bolts, shafts, gears, bearings, stripper, pins, and rollers should be free of cracks, distortion, significant wear, and corrosion. Evidence of same can be detected visually or via detection of unusual sounds during operation.	Replace.
Chain Guide	Visual	Excessive wear or press mark.	Replace.
Bolts, Nuts and Rivets	Visual, Check with Proper Tool	Bolts, nuts, and rivets should not be loose, deformed, or corroded.	Tighten or replace as required.
Warning Labels	Visual	Warning Labels should be affixed to the hoist (see Section 1.2) and they should be legible.	Replace.
Hoist Capacity Label	Visual	The label that indicates the capacity of the hoist should be legible and securely attached to the hoist.	Replace.

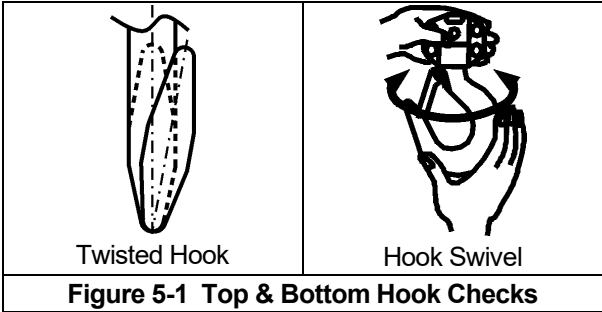
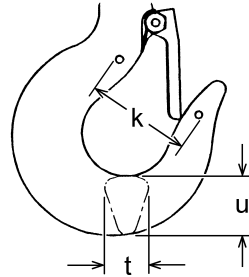


Table 5-5 Top Hook & Bottom Hook Dimensions

"k" Measured When New:

Top: _____

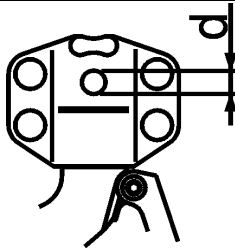
Bottom: _____



Product Code	Nominal "k" Dimension* inch (mm)	"u" Dimension inch (mm)		"t" Dimension inch (mm)	
		Standard	Discard	Standard	Discard
CF005	1.76 (44.6)	0.67 (17.0)	0.59 (15.0)	0.47 (12.0)	0.43 (10.8)
CF010	1.92 (48.8)	0.86 (21.8)	0.79 (20.0)	0.63 (16.0)	0.57 (14.4)
CF015	2.22 (56.3)	1.04 (26.5)	0.94 (24.0)	0.79 (20.0)	0.71 (18.0)
CF020	2.36 (59.9)	1.18 (30.0)	1.06 (27.0)	0.87 (22.0)	0.78 (19.8)
CF030	2.72 (69.1)	1.48 (37.5)	1.34 (34.0)	1.06 (27.0)	0.96 (24.3)
CF050	3.06 (77.8)	1.87 (47.5)	1.69 (43.0)	1.38 (35.0)	1.24 (31.5)

* These values are nominal since the dimension is not controlled to a tolerance. The "k" dimension should be measured when the hook is new - this becomes a reference measurement. Subsequent measurements are compared to this reference to make determinations about hook deformation/stretch. See Table 5-4, "Hooks - Stretch".

Table 5-6 Chain Pin Hole and Top Pin Hole Wear Dimensions



Product Code	Hole Diameter (d)			
	Chain Pin Hole inch (mm)		Top Pin Hole inch (mm)	
	Standard	Discard	Standard	Discard
CF005	0.252 (6.4)	0.272 (6.9)	0.480 (12.2)	0.500 (12.7)
CF010, CF020	0.319 (8.1)	0.339 (8.6)	0.480 (12.2)	0.500 (12.7)
CF015, CF030, CF050	0.350 (8.9)	0.370 (9.4)	0.638 (16.2)	0.658 (16.7)


Table 5-7 Body Top Pin Wear Dimensions		
		
Product Code	"d" Dimension inch (mm)	
	Standard	Discard
CF005	0.472 (12)	0.433 (11)
CF010, CF020	0.472 (12)	0.433 (11)
CF015, CF030, CF050	0.630 (16)	0.591 (15)

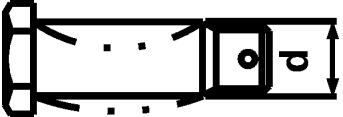
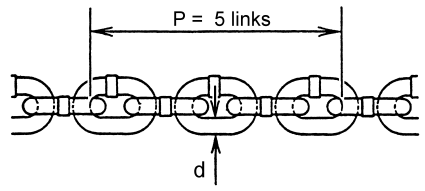
Table 5-8 Chain Pin Wear Dimensions		
		
Product Code	"d" Dimension inch (mm)	
	Standard	Discard
CF005	0.244 (6.2)	0.232 (5.9)
CF010, CF020	0.311 (7.9)	0.295 (7.5)
CF015, CF030, CF050	0.343 (8.7)	0.327 (8.3)

Table 5-9 Chain Wear Dimensions				
				
Product Code	"P" Dimension inch (mm)		"d" Dimension inch (mm)	
	Standard	Discard	Standard	Discard
CF005	2.97 (75.5)	3.05 (77.4)	0.20 (5.0)	0.18 (4.5)
CF010, CF020	3.76 (95.5)	3.85 (97.9)	0.25 (6.3)	0.22 (5.7)
CF015, CF030, CF050	4.18 (106.2)	4.29 (108.9)	0.28 (7.1)	0.26 (6.5)

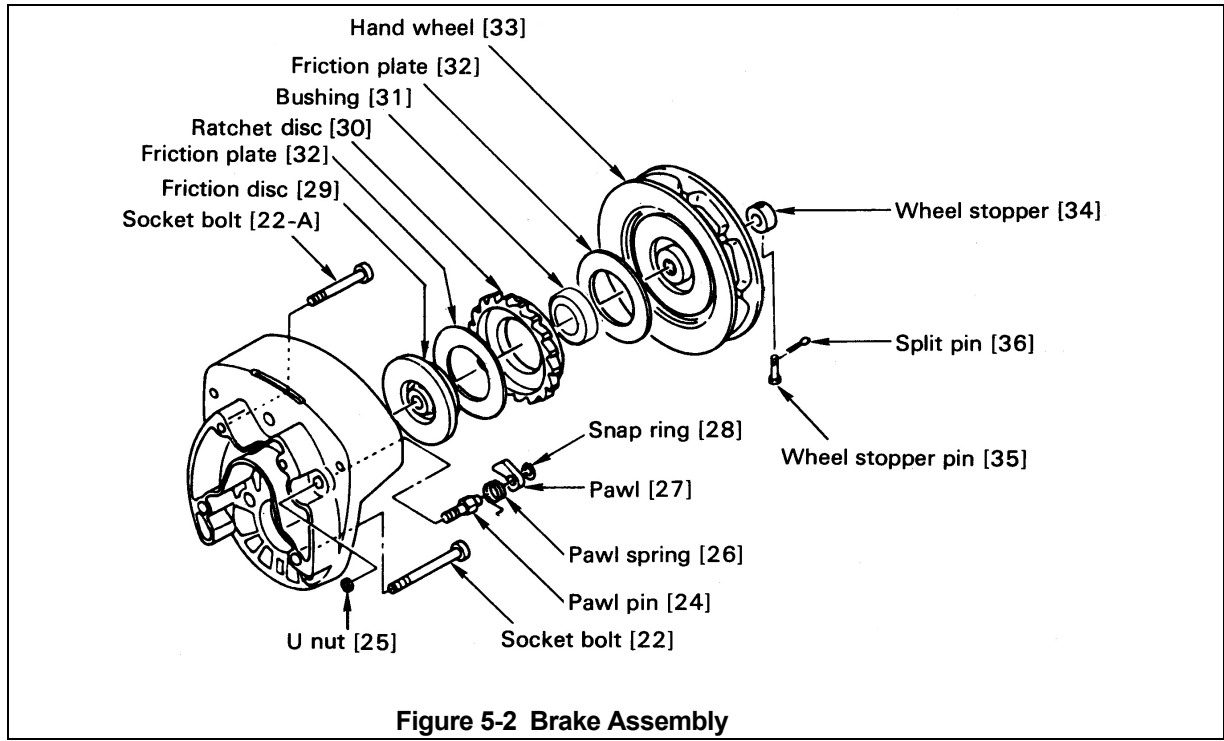


Figure 5-2 Brake Assembly

Table 5-10 Friction Plate Wear Dimensions

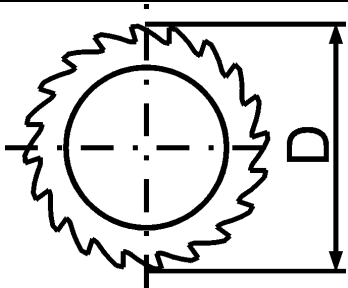
Product Code	Thickness inch (mm)	
	Standard	Discard
All	0.118 (3.0)	0.098 (2.5)

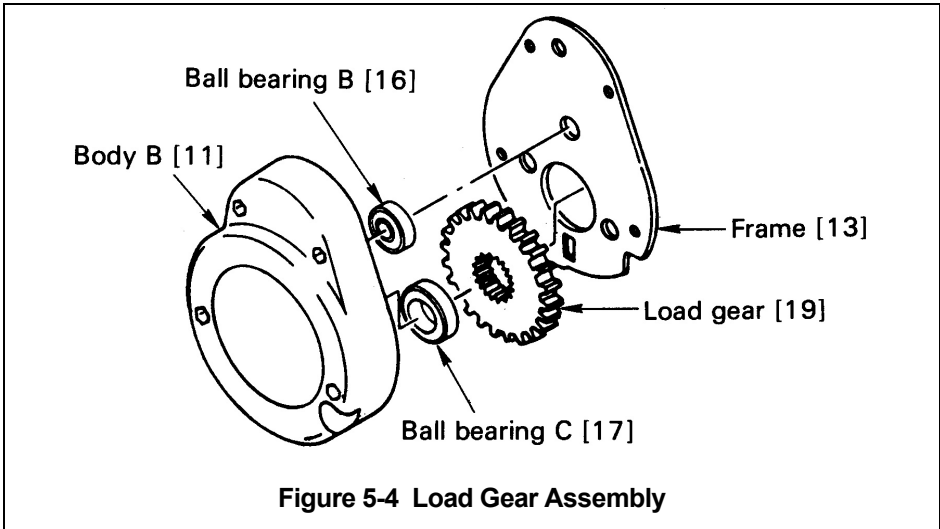
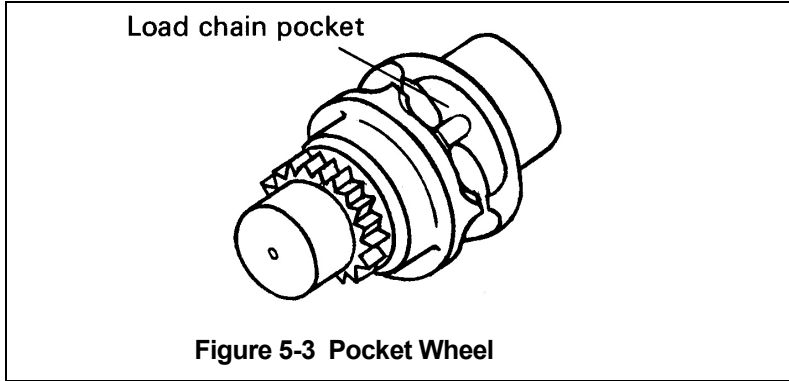
Table 5-11 Brake Bushing Wear Dimensions

Bushing [31]
t: Radial thickness

Product Code	A Dimension inch (mm)	
	Standard	Discard
CF005	0.118 (3.0)	0.079 (2.0)
CF010, CF015, CF020, CF030, CF050	0.157 (4.0)	0.118 (3.0)

Table 5-12 Brake Ratchet Disc Wear Dimensions

		
Product Code	D Dimension inch (mm)	
	Standard	Discard
CF005	3.425 (87)	3.307 (84)
CF010, CF015, CF020, CF030, CF050	3.858 (98)	3.740 (95)

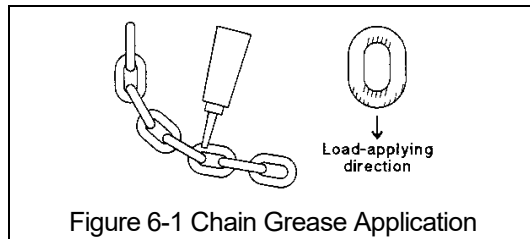


6.0 Maintenance and Handling

6.1 Lubrication

6.1.1 Load Chain

- For longer life, the load chain should be lubricated.
- The load chain lubrication should be accomplished after cleaning the load chain with an acid free cleaning solution.
- Apply Harrington lubricating grease (Part No. ER2CS1951) or an equivalent to industrial general lithium grease, NLGI No. 0, to the bearing surfaces of the load chain links as indicated by the shaded areas in Figure 6-1. Also apply the grease to the areas of the load chain (shaded areas in Figure 6-1) that contact the load sheave. Insure that the grease is applied to the contact areas in the load sheave pockets.
- Machine or gear oil (grade ISO VG 32, 46 or 68 oil or equivalent) may be used as an alternative lubricant but must be applied more frequently.



- The chain should be lubricated every 3 months (more frequently for heavier usage or severe conditions).
- For dusty environments, it is acceptable to substitute a dry lubricant.

6.1.2 Hooks and Suspension Components:

- Hooks – Bearings should be cleaned and lubricated at least once per year for normal usage. Clean and lubricate more frequently for heavier usage or severe conditions.
- Suspension Pins - Lubricate the chain pin and the top pin at least twice per year for normal usage; more frequently for heavier usage or severe conditions.

6.1.3 Applying Grease to Gears:

- Remove body B as instructed in Section 6.3.
- Remove old grease and replace the new grease (NLGI No. 2), at annual inspection.
- Temperature range of standard grease is -20°C (-4°F) to + 60°C (140°F). If the hoist is used at temperatures below -20°C (-4°F) or above 60°C (140°F), consult the manufacturer or dealer since some parts should be changed.

Table 6-1 General Lubrication			
Parts to be Lubricated	Name of Oil	Amount of Lubrication and Lubricating Method	Frequency of Lubrication
Mechanical Brake Parts: Ratchet Disc, Pawl Pin, Screw parts of Pinion	Machine or Gear Oil	Wipe off oil with waste cloth after applying proper amount of oil.	When the hand pull becomes extremely heavy in lowering operations.

6.2 Disassembly, Assembly and Adjustment

6.2.1

NOTICE

- 1) Perform proper disassembly or assembly in accordance with this manual.
- 2) The hoist utilizes dry friction plates; they are not to be lubricated.
- 3) Do not extend the load chain.
- 4) Remove old grease on the disassembled parts.
- 5) Replace components with Harrington Hoist approved parts.
- 6) To reassemble, apply new grease, and use a new split pin and snap ring.

6.2.2 Tools – The following tools are required to disassemble/reassemble the hoist.

No.	Tool	Operation
1	Snap ring pliers	Opening a snap ring
2	Metric socket wrenches	Slotted nuts
3	Metric hex keys (Allen wrenches)	Socket head cap screws
4	Metric wrenches	Bolts and nuts
5	Phillips screwdriver	Machine screws
6	Pliers (Needle Nose)	Split pins
7	Soft-face (Dead blow) hammer	
8	Wooden Blocks	Elevate hoist

6.3 Hoist Disassembly

Proceed as follows (**Note: Figures in brackets are Figure Numbers in Parts List**):

- 1) Orient a hoist with wheel cover side up.
- 2) Unscrew three screws [38] (with spring washers [39]) that attach the wheel cover [37].
- 3) Remove the wheel cover [37] from the body A [10].
- 4) Insert a vertical link of the hand chain [43] into the notch of the hand wheel [33] and remove the hand chain by turning the hand wheel counterclockwise.

NOTE: Bring the notch of the hand wheel to the right hand side.

- 5) Pull out split pin [36] from the wheel stopper pin [35] and remove the wheel stopper pin and wheel stopper [34] from the pinion [14].
- 6) Remove the hand wheel [33] from the pinion [14] by turning the hand wheel counterclockwise.

NOTE: If the hand wheel is too tight to turn by hand, put hand chain on the hand wheel again and pull it down hard. It will release the brake.

- 7) Remove two friction plates [32], ratchet disc [30] and bushing [31] from the friction disc [29].
- 8) Remove the friction disc [29] from the pinion [14] by turning counterclockwise holding the end of the pinion with your fingers.
- 9) Remove snap ring [28] from the pawl pin [24] (on the body A [10]) and then remove pawl [27] and pawl spring [26].
- 10) Unscrew the pawl pin [24].

NOTE: The pawl pin is fixed with the U nut [25].

11) Unscrew four socket bolts [22, 22-A] connecting body A [10] and B [11].

NOTE: Four socket bolts are fixed with U nuts [23] on the body B side.

12) Separate the body A [10] and B [11].

13) Take ball bearing A [15] and C [17-A] out of the body A [10] (only if bearing needs replaced).

14) Remove the top hook [1] and top pin [3] from the body B [11].

15) Remove pinion [14], chain guide [20] (or guide rollers [20-A]), stripper [21], tail pin [40], and load chain [42].

16) Remove the frame [13].

17) Take load sheave [18] out of the load gear [19].

18) Remove the load gear [19].

19) Unscrew tap socket bolt [41] from the body B [11].

20) Pull split pin [9] out of the slotted nut [8] and remove the slotted nut and chain pin [7] from the bottom hook [4].

6.4 Hoist Assembly

6.4.1 **⚠ WARNING**

- Inspect and replace any worn or damaged parts per Table 5-3.
- Secure all nuts, bolts and split pins firmly.
- Replace all split pins and retaining rings.

6.4.2 Assembly

1) Wipe off old grease from the body B [11] and frame [13].

2) Apply new grease to the ball bearing B [16] and C [17] on the body B [11].

3) Insert load sheave [18] into the load gear [19] and put them together on the ball bearing C [17].

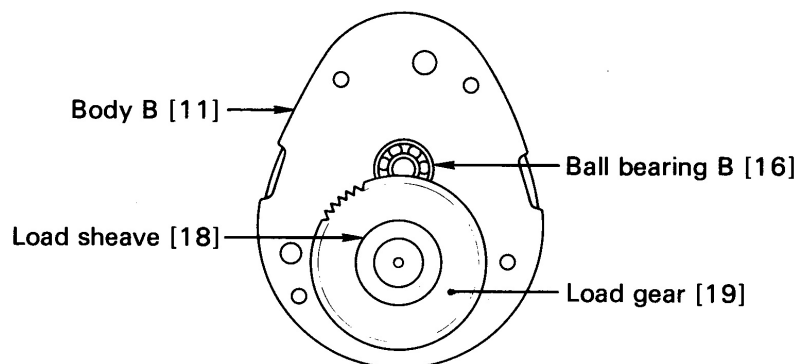


Figure 6-2 Load Gear Assembly

4) Apply new grease to the load gear [19].

5) Put frame [13] on the body B [11] according to pattern.

- 6) Insert the end of the load chain [42] to the bottom hook [4] and fix them with the chain pin [7], slotted nut [8] and split pin [9]. For Bullard®, Shur-loc®, or Inspection type hooks, refer to Table 6-3 for yoke nut torque specifications.

⚠ WARNING : Always bend the split pin securely.

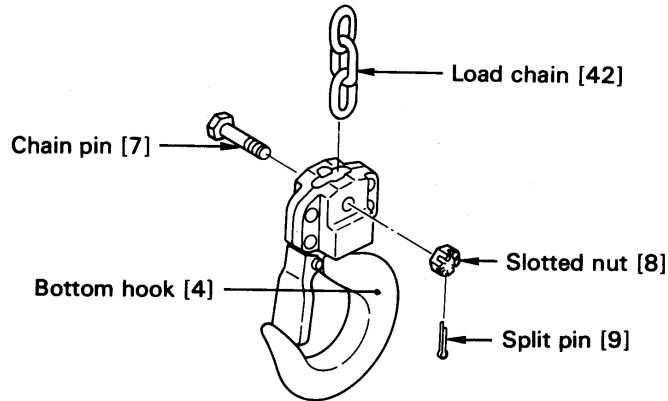


Figure 6-3 Bottom Hook Assembly

- 7) Place the load chain [42] on the load sheave [18] so that the bottom hook side comes to right hand and the end link of the other side becomes vertical to the load sheave pocket.

⚠ WARNING : Put the welded part of the vertical chain link outward.

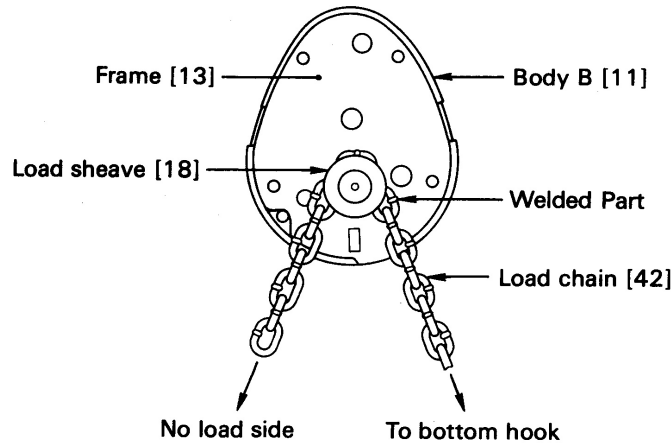


Figure 6-4 Load Chain Assembly

- 8) Put chain guide [20] (or guide rollers for ½ ton [20-A]) on the frame [13].

⚠ WARNING : Fit the larger boss of chain guide [20] into holes on frame [13].

- 9) Put stripper [21] on the frame [13].
- 10) Insert pinion [14] shaft from its gear side through the frame [13] and into ball bearing B [16].
- 11) Insert top pin [3] into the frame [13] and put top hook [1] to the top pin. For Bullard®, Shur-loc®, or Inspection type hooks, refer to Table 6-3 for yoke nut torque specifications.

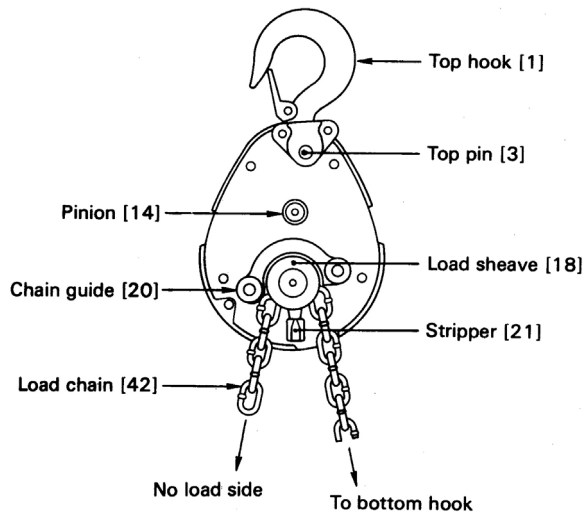


Figure 6-5 Chain Guide Assembly

12) Clean and grease ball bearing A [15] and D [17-A] and insert into body A [10] (if being replaced).

13) Put the body A [10] with the ball bearings [15, 17-A] side down on the body B [11].

⚠ WARNING : Make sure each part is completely set between body A [10] and frame [13].

14) Insert four socket bolts [22, 22-A] into the body A [10] and turn the whole body sideways. Then fix the bolts with the U nuts [23] holding the U nuts with fingers. Make sure locking tab on U nuts face out, and tighten bolts to 10 – 12 lb/ft.

⚠ WARNING : Insert short socket bolts [22-A] to the upper holes and long socket bolts [22] to the lower holes.

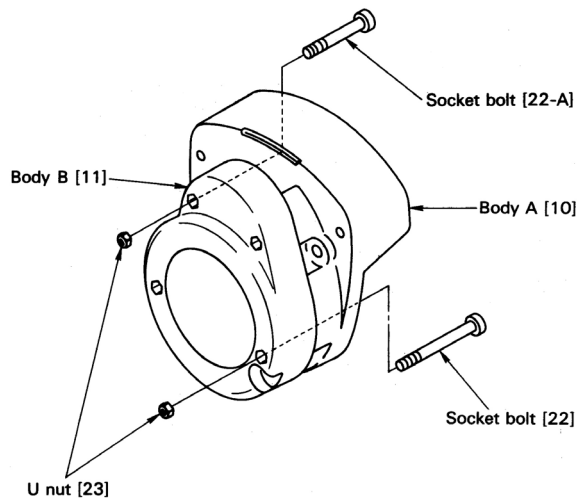


Figure 6-6 Body "A" Assembly

15) Insert pawl pin [24] into the body A [10] and fix it with the U nut [25] tighten to 10 – 12 lb/ft.

16) Apply machine oil to the pawl pin [24] and join pawl spring [26] and the pawl [27] respectively to it. Fix the pawl with snap ring [28].

⚠ WARNING : Make sure the pawl spring is fixed to the pawl and the snap ring is securely set at the groove of the pawl pin.

17) Thread friction disc [29] on the pinion [14].

18) Wipe out any dirt on the friction disc [29], friction plates [32] and both sides of the ratchet disc [30] and make sure that bushing [31] is properly soaked with oil. Then place the friction plate, bushing, ratchet disc (while the pawl [27] is rotated counterclockwise), and friction plate respectively on the friction disc. (Make sure that the pawl meshes with the ratchet disc properly.)

⚠ WARNING : **NEVER** apply oil since the brake is a “dry system”. Thoroughly wipe out any oil and dirt on the brake. The gear of the ratchet should point at the pawl. Otherwise, the hand wheel cannot be assembled later.

In case the bushing does not have oil inside, soak it in turbine oil for a day. Install it without wiping the oil. Make sure that the pawl meshes with the ratchet disc properly.

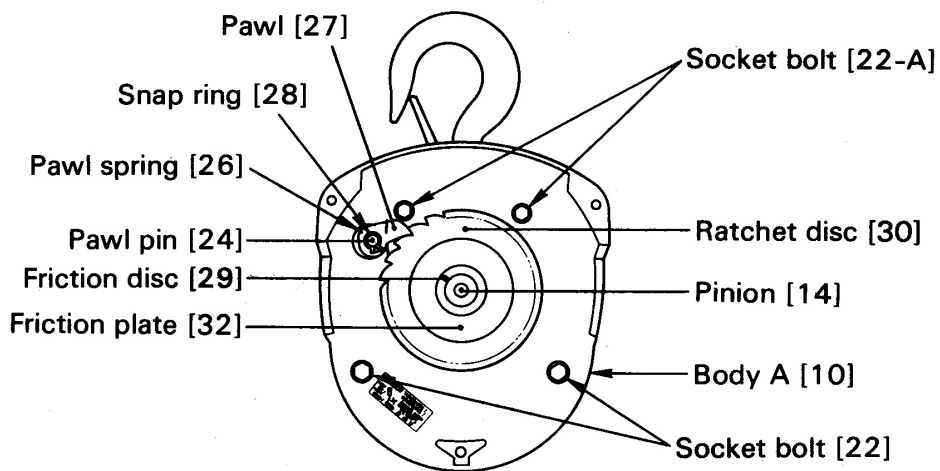


Figure 6-7 Brake Assembly

19) Remove the dirt from the hand wheel [33] and apply machine oil to the threaded part. Assemble onto the pinion shaft [14] by turning it clockwise as far as possible.

20) Place wheel stopper [34] on the head of the pinion [14], insert wheel stopper pin [35] and fix it with a split pin [36].

⚠ WARNING : **NEVER** forget to bend the split pin after inserting into the wheel stopper pin.

21) Set the notch of the hand wheel to the left hand side. Insert the vertical link of the hand chain [43] into the notch of the hand wheel [33] and reeve the hand chain by turning the hand wheel clockwise.

NOTE: Make sure welds on hand chain are to the outside of the hand wheel.

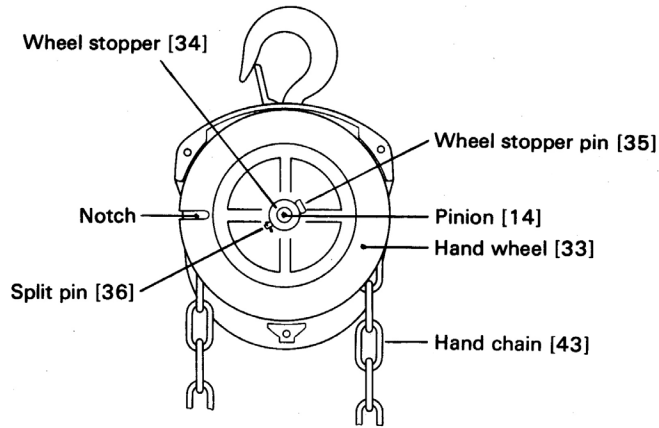


Figure 6-8 Hand Wheel Assembly

- 22)** Put wheel cover [37] on the body A [10] and fix them with the spring washers [39] and screws [38].
- 23)** Put a hoist with body B [11] side up. Place the slack end of the load chain between body A [10] and body B [11]. Then insert tail pin [40], and screw tap socket bolt [41] into the body B until firmly seated against body B.

⚠ WARNING : Make sure the load chain is not twisted. Be careful not to cross thread or over torque tap socket bolt [41].

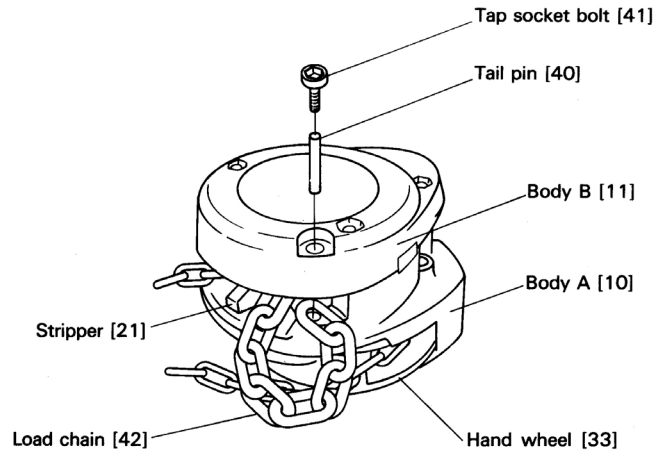


Figure 6-9 Body "B" Assembly

Table 6-3 Torque Specifications for Yoke Nuts (in-lb)

Cap. (Tons)	Product Code	Bottom Bullard®	Top Bullard®	Bottom Shur-loc®	Top Shur-loc®	Bottom Inspection	Top Inspection	Bottom SmartLok™	Top SmartLok™
1/2	CF005	55	55	55	55	55	55		
1	CF010	55	55	55	55	55	55		
1½	CF015	85	85	85	85	85	85		
2	CF020	199		199				199	
3	CF030	398		398				398	
5	CF050	398	398	398				398	

6.5 Chaining

- 6.5.1 Remove 3 Philips head screws from hand wheel cover and remove cover.
- 6.5.2 Remove the tap socket bolt [41] and tail pin [40] from body B [11].
- 6.5.3 Hang hoist with the capacity label facing you. Refer to figure 6-10.
- 6.5.4 Verify load and hand chains (if installing new hand chain) are the correct length and all end links are in the same plane. Refer to figure 6-11.
- 6.5.5 Attach one end of load to the factory installed leader chain on the LEFT side of the hoist using an open or "C" link. Refer to figure 6-10. Make certain the weld on the vertical (standing) link is facing away from the load sheave.

NOTE: If there is no chain in the hoist, feed a piece of mechanics type wire around the load sheave and attach it to the new chain on the LEFT side of the hoist. The first link of chain into the hoist **MUST** be a vertical (standing) link. Make certain the welds on the vertical (standing) links are facing away from the load sheave.
- 6.5.6 Move to hand wheel side of hoist.
- 6.5.7 Rotate hand wheel clockwise (should hear clicking sound) until there is approximately 1 foot of new chain extending from hoist.
- 6.5.8 Remove open link and leader chain from new chain.
- 6.5.9 Move to capacity label side of hoist.

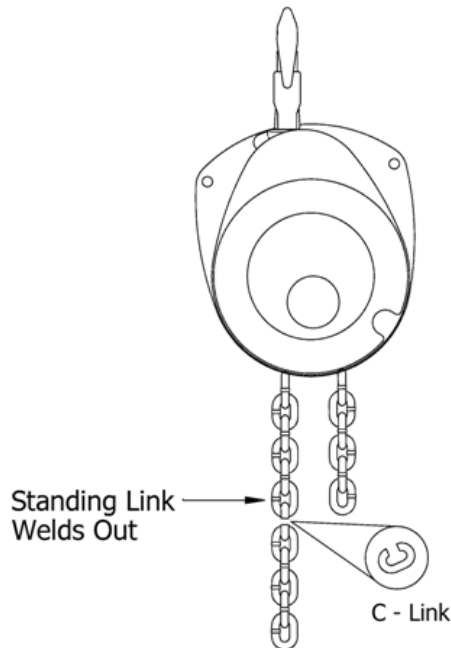


Figure 6-10 C-Link Install

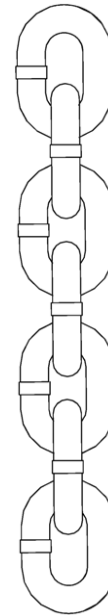


Figure 6-11 Plane of End Links

- 6.5.10 Attach the end of the load chain on the right side of the load sheave to the tail pin [40]. Refer to Figure 6-12. Make sure there are no twists in the chain.

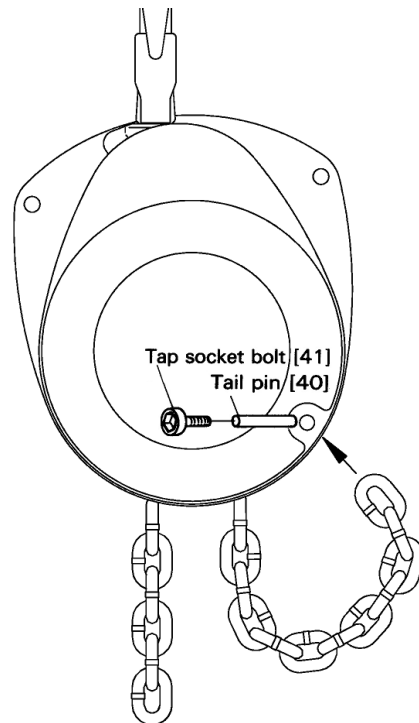


Figure 6-12 Tail Pin Install

- 6.5.11 Install the tap socket bolt [41] into body B [11] and tighten by hand until the surfaces of the tap bolt and body B are firmly mated.
- 6.5.12 Install bottom hook

For Single Fall Hoists

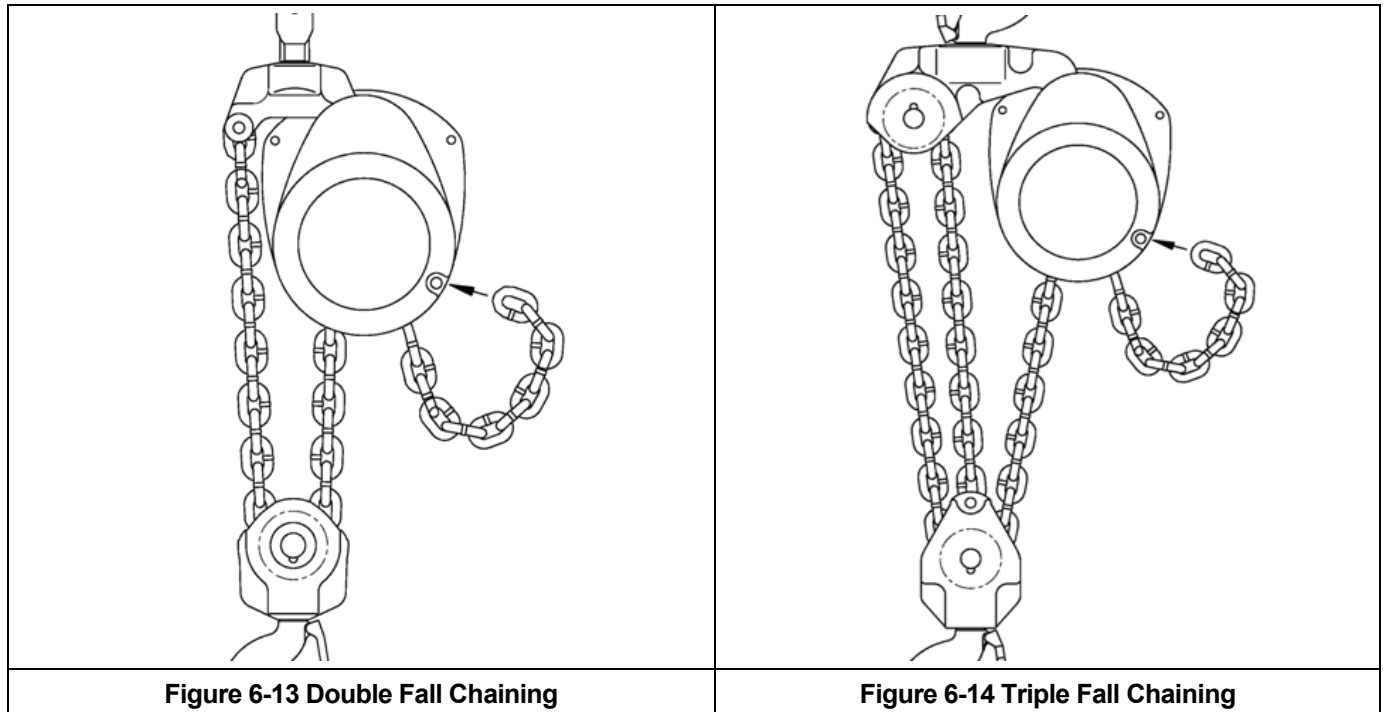
- a. Insert the last link of chain on the left side of the load sheave into the bottom hook yoke.
- b. Insert the chain pin into the bottom hook yoke and attach castle nut hand tight.
- c. Install NEW split pin in castle nut (loosen nut slightly if necessary to align slots in nut with hole in chain pin).

⚠WARNING : NEVER forget to bend the split pin after inserting into the castle nut.

For Double Fall Hoists

- a. Feed a piece of small diameter mechanics type wire through the bottom hook block around the idle sheave.
- b. Make sure there are no twists in the load chain and attach the load chain to the wire in the bottom hook block.
- c. Feed the chain into the bottom hook block, making sure that the welds are facing the idle sheave. Refer to Figure 6-13.
- d. Remove wire from the chain and insert the end link of chain into the top hook block.
- e. Install chain pin, castle nut, and split pin.

⚠WARNING : NEVER forget to bend the split pin after inserting into the castle nut.



For Triple Fall Hoists

- a. Feed a piece of small diameter mechanics type wire around the idle sheaves in the top and bottom hook blocks.
- b. Make sure there are no twists in the load chain and attach the load chain to the wire in the bottom hook block.
- c. Feed the chain into the bottom hook block, making sure that the welds are facing the idle sheave. Refer to Figure 6-13.
- d. Attach the load chain to the wire in the top hook block and pull it around the idle sheave so that the end of the chain will exit the idle sheave towards the center of the bottom hook block. Refer to Figure 6-14.
- e. Install chain pin, castle nut, and split pin

⚠ WARNING : NEVER forget to bend the split pin after inserting into the castle nut.

6.5.13 Install hand chain

6.5.13.1 Stand facing the hand wheel side of the hoist.

6.5.13.2 Place the end link of hand chain flat in a pocket on the left side of the hand wheel and turn hand wheel clockwise. The welds on the standing link should face away from the hand wheel.

6.5.13.3 When the first link of chain comes out on the right side of the hand wheel, place a master link (connecting link) onto the end link and hold in position.

NOTE: Do not turn or twist the chain.

6.5.13.4 Keep pulling hand chain through the hoist until the last link of hand chain hangs in proper alignment with the pockets on the hand wheel, and attach the master link from the other end of hand chain.

6.5.13.5 Close master link in a vise.

6.5.13.6 Attach the warning tag to the chain stopper link and install the chain stopper link around the hand chain.

6.6 Storage

6.6.1 **⚠ WARNING** : **IMPROPER** chain hoist use could result in death or serious injury. To avoid these hazards:

- **ALWAYS** store the hoist in a no load condition.
- **ALWAYS** wipe off all dirt and water.
- **ALWAYS** oil the chain, hook pins and hook latches.
- **ALWAYS** hang in a dry place.
- **ALWAYS** check the hoist for abnormalities (according to the regular inspection procedures) when using the hoist after a period of non-use (Refer to section 5.5).

6.7 Outdoor Installation

- 6.7.1 The hoist/trolley should be covered when not in use.
- 6.7.2 The hoist/trolley **MUST BE** inspected and maintained according to the 'Severe Service' Inspection Classification. **Refer to Section 5.0.**
- 6.7.3 When using a steel chain container, remove the plug to allow for the drainage of pooling water. Canvas chain containers are not recommended for outdoor use.
- 6.7.4 Possibility of corrosion on components of the hoist increases for installations where salt air and high humidity are present. For installations where temperature variations introduce condensation/corrosion into the hoist, more frequent lubrication may be required.
- 6.7.5 Refer to **Section 2.1.2** for allowable environmental conditions.

7.0 Troubleshooting

⚠ WARNING

Read and comply with instructions in this manual and use the hoist properly.
 Checking the sounds from the hoist in operation is a critical inspection. Note hoist sounds during operation.
 If a defect is found in the hoist, stop using it immediately and check the cause of the defect.
 Only Trained and competent personnel should inspect and repair the hoist.

Table 7-1 Troubleshooting Guide

Note on proper operation:

- When lifting, the hoist should make clicking sounds when moving the hand wheel.
- When lowering, the hoist should not make clicking sounds when moving the hand wheel.

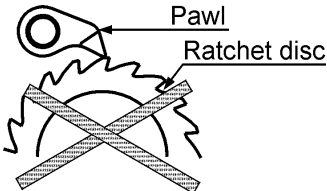
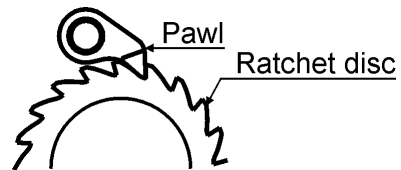
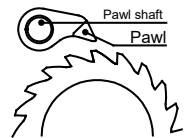
Symptom	Cause	Remedy
Hoist will not lift – Slight clicking	Improper assembly of ratchet disc, disc installed backwards, and making incorrect contact with the pawl. 	Reassemble the pawl and ratchet disc properly. Ensure that clicking sounds are heard before reuse. 
Hoist will not lift – Not Clicking	Pawl not engaging ratchet disc: ■ Dirt or corrosion between pawl and pawl shaft.	Clean and lubricate pawl and pawl shaft. 
	Faulty pawl spring	Replace pawl spring
	Loose selector pawl spring	Perform hoist maintenance.
Hoist will lift intermittently – Slight or irregular clicking	Poor pawl movement caused by faulty pawl spring. The spring is loose or damaged.	Perform maintenance and/or repair.
	Mis-assembly of pawl spring	Reassemble it properly and ensure to check click sound of the pawl before reuse.

Table 7-1 Troubleshooting Guide

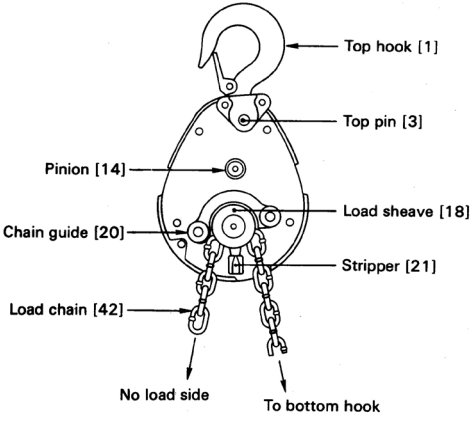
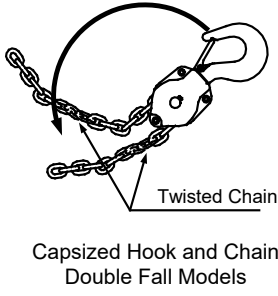
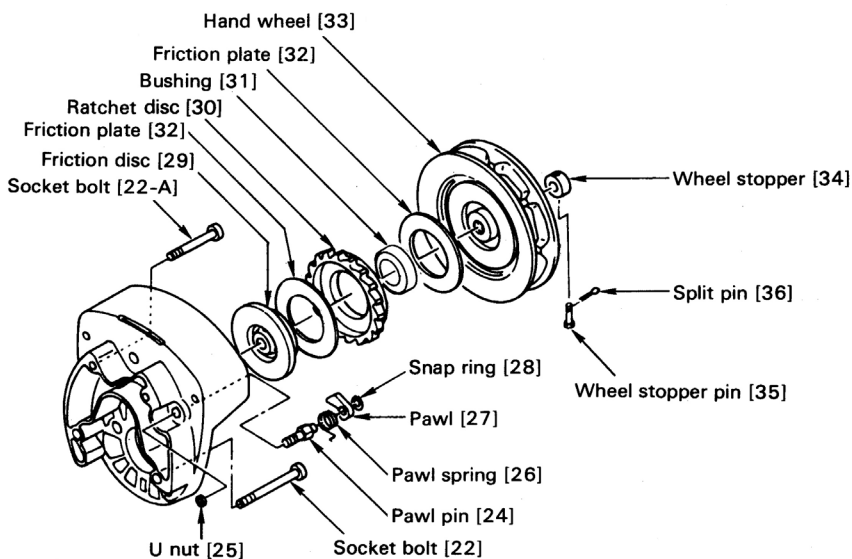
Symptom	Cause	Remedy
<p>During operation, hoist idles or load drifts</p>	<p>Poor load sheave and load chain contact caused by improper chain-reeving.</p>	<p>Reassemble properly and ensure proper lifting before reuse.</p> 
<p>Hoist will not lift all the way (multiple fall hoists)</p>	<p>Capsized hook</p>	<p>Reset the capsized hook.</p> 
<p>Hoist does not lift load smoothly.</p>	<p>Improper assembly of gear OR bearing broken.</p>	<p>Disassemble and reassemble gear train and/or replace bearing.</p>

Table 7-1 Troubleshooting Guide

⚠ CAUTION Improper braking may cause improper load lowering. The hoist utilizes dry friction discs; do not apply oil to friction surfaces.



Symptom	Cause	Remedy
Load will not go down	Over tightened brake The hoist left under load for a long period Shock loaded during operation	Pull down hard (possibly with 2 people) on the hand chain to loosen brake.
	Brake rusted tight	Replace the rusty components and perform hoist maintenance.
Load drifts or slips when lowering	A foreign object between friction surfaces.	Remove the object and clean the surfaces. Replace if the friction surface is scarred.
	Brake slip caused by significant rust	Replace the rusty component and perform hoist maintenance.
	Mis-assembly of friction plates, i.e. friction plates missing or at one side as shown.	Reassemble properly as shown and ensure hoist functions properly before reuse.
	Cracked friction plate caused by overload	Replace the friction plate and use the hoist properly within rated capacity.
Friction plate wear caused by very frequent and long term use.	Perform hoist maintenance.	

8.0 Warranty

All products sold by Harrington Hoists, Inc. are warranted to be free from defects in material and workmanship from date of shipment by Harrington for the following periods:

- 1 year – Electric and Air Powered Hoists (excluding (N)ER2 Hoists and EQ/SEQ Hoists), Powered Trolleys, Powered Tiger Track Jibs and Gantries, Crane Components, Below the Hook Devices, Spare / Replacement Parts**
- 2 years – Manual Hoists & Trolleys, Beam Clamps**
- 3 years – (N)ER2 Hoists, EQ/SEQ Hoists, (T)EM/(T)SEM hoists, and RY Hoists**
- 5 years – Manual Tiger Track Jibs and Gantries, Hoist Motor Brakes for TNER, EQ/SEQ, (T)EM/(T)SEM, and RY**
- 10 years – (N)ER2 Brake, Tiger Track Workstation Cranes, and Monorails**

The product must be used in accordance with manufacturer's recommendations and must not have been subject to abuse, lack of maintenance, misuse, negligence, or unauthorized repairs or alterations.

Should any defect in material or workmanship occur during the above time period in any product, as determined by Harrington Hoist's inspection of the product, Harrington Hoists, Inc. agrees, at its discretion, either to replace (not including installation) or repair the part or product free of charge and deliver said item F.O.B. Harrington Hoists, Inc. place of business to customer.

Customer must obtain a Return Goods Authorization as directed by Harrington or Harrington's published repair center prior to shipping product for warranty evaluation. An explanation of the complaint must accompany the product. Product must be returned freight prepaid. Upon repair, the product will be covered for the remainder of the original warranty period. Replacement parts installed after the original warranty period will only be eligible for replacement (not including installation) for a period of one year from the installation date. If it is determined there is no defect, or that the defect resulted from causes not within the scope of Harrington's warranty, the customer will be responsible for the costs of returning the product.

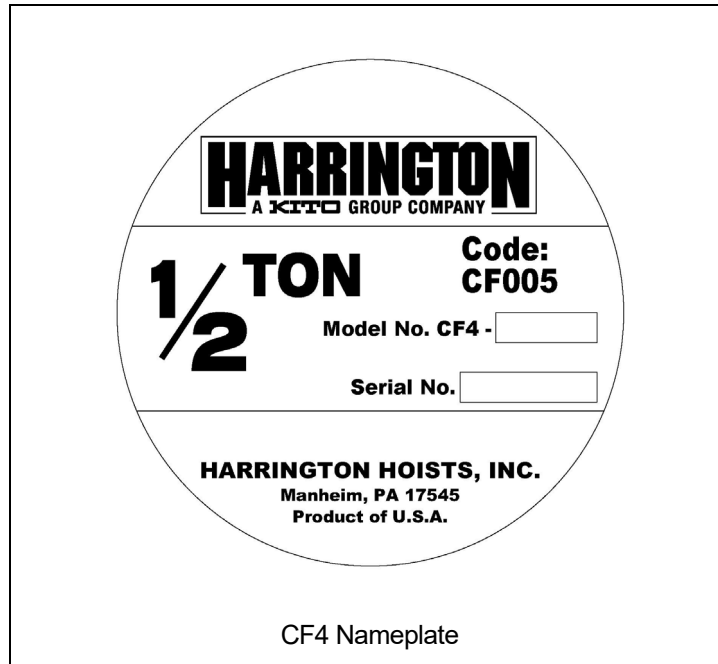
Harrington Hoists, Inc. disclaims any and all other warranties of any kind expressed or implied as to the product's merchantability or fitness for a particular application. Harrington will not be liable for death, injuries to persons or property or for incidental, contingent, special or consequential damages, loss or expense arising in connection with the use or inability whatever, regardless of whether damage, loss or expense results from any act or failure to act by Harrington, whether negligent or willful, or from any other reason.

This Page Intentionally Left Blank

9.0 Parts List

When ordering Parts, please provide the Hoist code number, lot number and serial number located on the Hoist nameplate (see Figure below).

Reminder: Per Sections 1.1 and 3.4.4 to aid in ordering parts and product support, record the hoist Code, Lot and Serial Number in the space provided on the cover of this manual.



The parts list is arranged into the following sections:

Section	Page
9.1 1/2 to 5 Ton Parts.....	43
9.2 Additional 2 through 5 Ton Parts.....	45
9.3 Optional Hooks.....	46
9.4 Optional Chain Containers.....	48

9.1 1/2 to 5 Parts

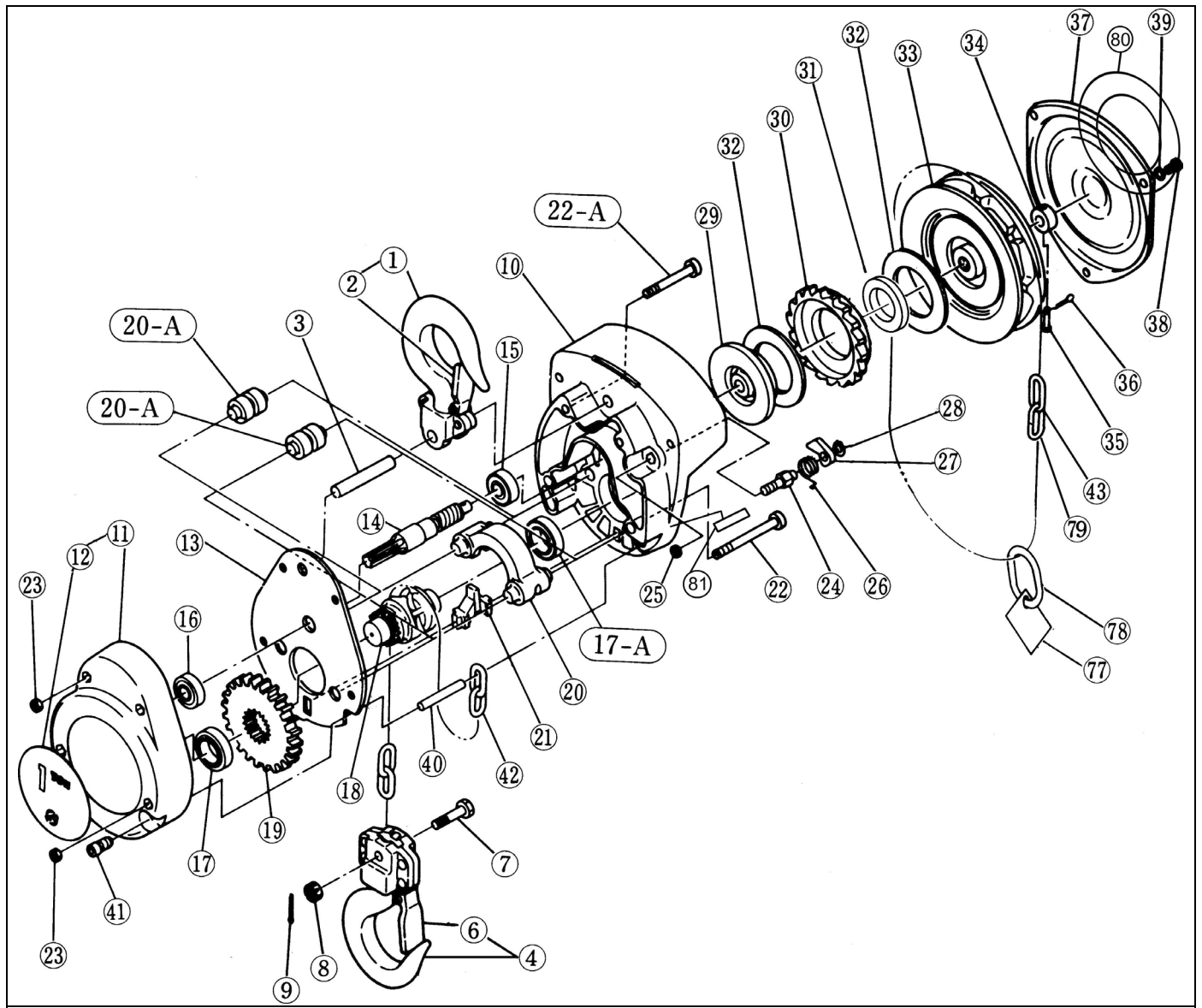


Figure 9-1 1/2 to 5 Ton Parts

9.1 1/2 to 5 Ton Parts

Fig. No.	Name	Parts / Hoist	1/2 Ton	1Ton	2 Ton	1 1/2 Ton	3 Ton	5 Ton	
1	Top Hook Assembly	1	CF001005	CF001010		CF001015			
2	Latch Assembly	1	CF071005	CF071010		CF071015			
3	Top Pin	1	CF163005	CF163010			CF163015		
4	Bottom Hook Complete Set	1	M3021A005	M3021A010		M3021A015			
6	Latch Assembly	1	CF071005	CF071010		CF071015			
7	Chain Pin	1	M3041005	M3041010		M3041015			
8	Slotted Nut	1	M3049005	M2049010		M2049010			
9	Split Pin	1	9009402	9009411		9009411			
10	Body A	1	CF101005	CF101010			CF101015		
11	Body B	1	CF102005	CF102010			CF102015		
12	Adhesive Nameplate – S/N Blank	1	80346	80347	80349	80348	80350	80351	
		1							
13	Frame	1	CF105005	CF105010			CF105015		
14	Pinion	1	CF4111005	CF4111010			CF4111015		
15	Ball Bearing A (Fig. 14)	1	9000102	9000103					
16	Ball Bearing B (Fig. 14)	1	9000201			9000202		9000300	
17	Ball Bearing C (Fig. 14)	1	9000104	9000105		9000106			
17A	Ball Bearing D (Fig. 14)	1	9000104	9000105		9000106			
18	Load Sheave	1	CF116005	CF116010		CF116015		CF116A050 (Assy)	
19	Load Gear	1	CF114005	CF114010		CF114015			
20	Chain Guide	1		CF178010		CF178015			
20A	Guide Roller	2	CF161005						
21	Stripper	1	CF162005	CF162010			CF162015		
22	Socket Bolt for Body	2	9091282	9091284			9091285		
22A	Socket Bolt for Body	2	9091280	9091282			9091283		
23	U-Nut for Body	4	ES857005S						
24	Pawl Pin	1	CF156005						
25	U-Nut for Fig. 24	1	ES857005S						
26	Pawl Spring	1	CF158005						
27	Pawl	1	CF155005						
28	Snap Ring for Fig. 24	1	9047108						
29	Friction Disc	1	M3153005	M3153020					
30	Ratchet Disc	1	CF4152005	CF4152010					
31	Bushing for Ratchet Disc	1	M3154005	M3154020					
32	Friction Plate	2	M3151005	M3151020					
33	Hand Wheel	1	CF4115005	CF4115010		CF4115015			
34	Wheel Stopper	1	CF159005	CF159010					
35	Wheel Stopper Pin	1	M2167005						
36	Split Pin for Fig. 35	1	9009485						
37	Wheel Cover	1	CF171005	CF171010		CF171015			
38	Screw for Fig. 37	3	CF187005						
39	Spring Washer for Fig. 37	3	9012709						
40	Tail Pin	1	CF164005	CF164010		CF164015			
41	Socket Bolt for Fig. 40	1	CF181005	CF181010					
42	Load Chain	Black	ft	LCCF005	LCCF010		LCCF015		
		Nickel Plated		LCCF005NP-DIN	LCCF010NP-DIN		LCCF015NP-DIN		
43	Hand Chain	Plain	ft	HCCF005A					
		Zinc		HCCF005ZNA					
79	Hand Chain Masterlink	Plain	1	HCCF005MLA					
		Zinc		HCCF005ZNMALA					
77	Warning Tag (WTAG9)	1	80146						
78	Chain Stopper Link	1	L5BA0329045						
80	Harrington Label	1	CF700005	CF700010		CF700015			
81	Nameplate F (Warning)	1	C3BA0059806						

9.2 Additional 2 through 5 Ton Parts

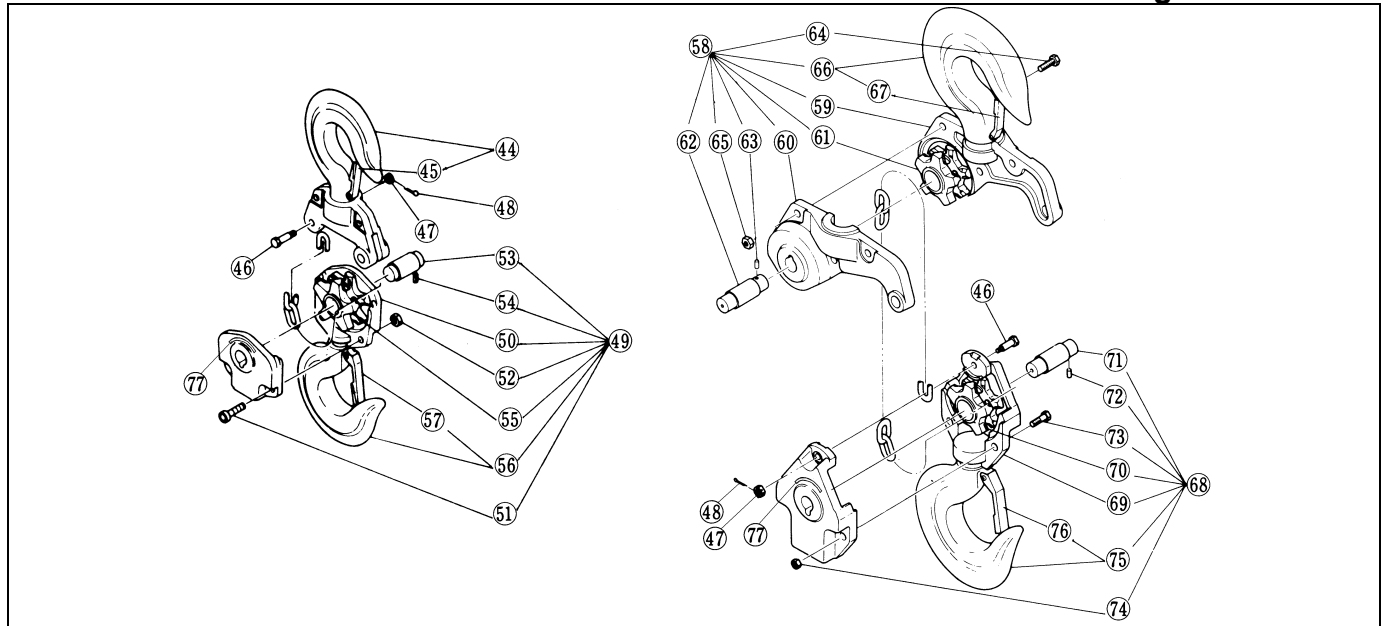


Figure 9-2 Additional 2 through 5 Ton Parts

Fig. No.	Name	Parts / Hoist	2 Ton	3 Ton	5 Ton
44	Top Hook Assembly	1	CF001020	CF001030	
45	Latch Assembly	1	CF071020	CF071030	
46	Chain Pin	1	CF041020	M3041030	
47	Slotted Nut for Fig. 46	1	M2049010		
48	Split Pin for Fig. 46	1	9009411		
49	Bottom Hook Complete Set	1	CF021A020	M3021A030	
50	Bottom Yoke	2	CF031020	M3031030	
51	Bolt	2	9091274	9091296	
52	U-Nut	2	ES857005S	ES066075	
53	Shaft	1	CF053020	CF053030	
54	Solid Pin	2	CF083020		
	Spring Pin	1		CF083030	
55	Idle Sheave	1	CF051020	CF051030	
56	Bottom Hook Assembly	1	CF021020	M3021030	
57	Latch Assembly	1	CF071020	CF071030	
77	Label	1	80173		
58	Top Hook Complete Set	1			CF001A050
59	Top Yoke A	1			CF011050
60	Top Yoke B	1			CF012050
61	Idle Sheave	1			CF051030
62	Shaft	1			CF053050
63	Spring Pin	1			CF083030
64	Socket Bolt	3			9091296
65	U-Nut	3			9098508
66	Top Hook Assembly	1			M3021050
67	Latch Assembly	1			CF071050
68	Bottom Hook Complete Set	1			CF021A050
69	Bottom Yoke Assembly	1			CF031050
70	Idle Sheave	1			CF051030
71	Shaft	1			CF053050
72	Spring Pin	1			CF083030
73	Socket Bolt	2			9091296
74	U-Nut	2			ES066075
75	Bottom Hook Assembly	1			M3021050
76	Latch Assembly	1			CF071050
77	Label (Do not capsize)	1			80173

9.3 Optional Hooks

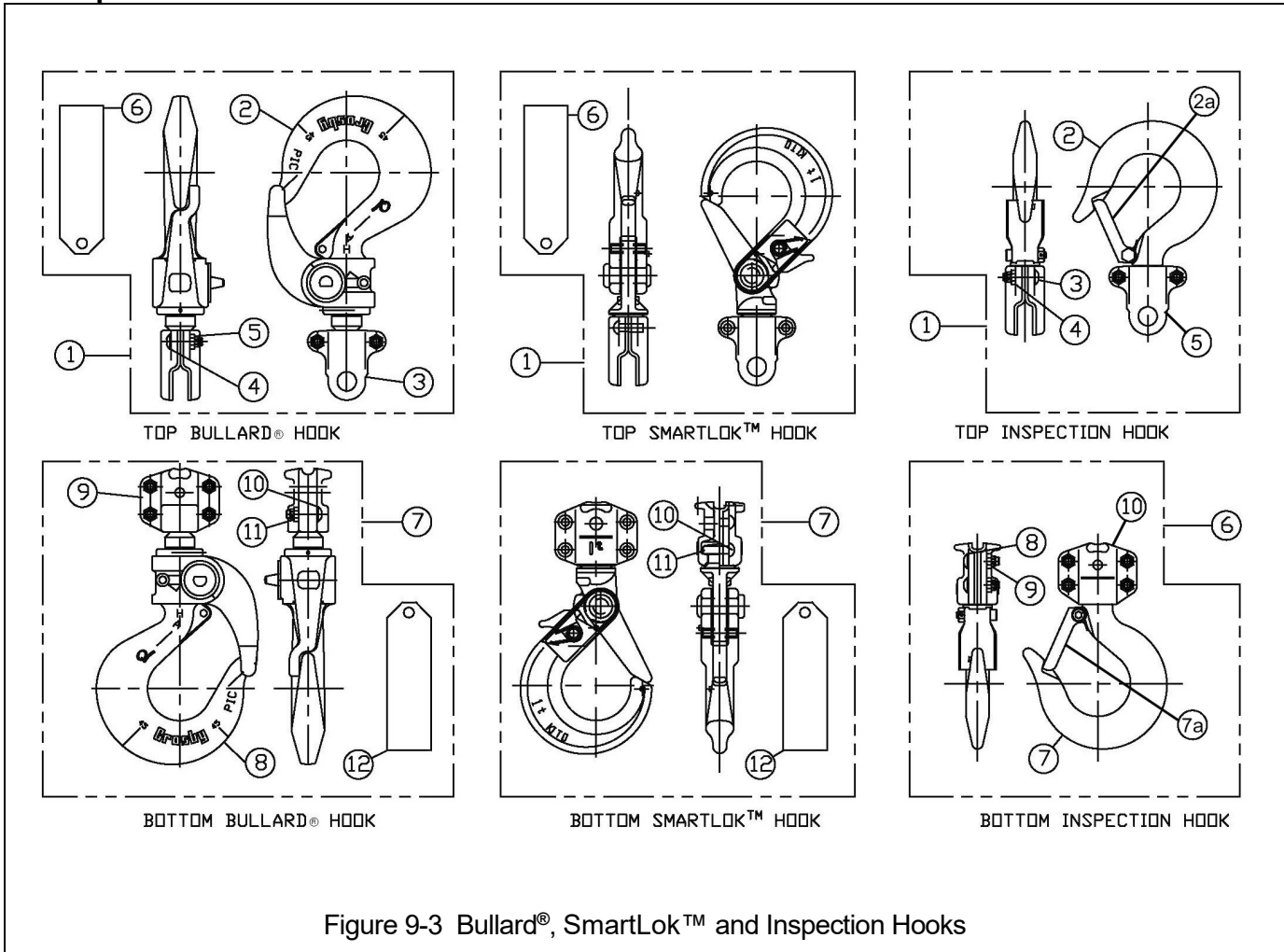


Figure 9-3 Bullard®, SmartLok™ and Inspection Hooks

Bullard® Hooks

Fig. No.	Name	Parts Per Hoist	1/2 Ton	1 Ton	1 1/2 Ton	2 Ton	3 Ton	5 Ton
1	Bullard® Top Hook Complete Set	1	6027601	6027602	6027603			6027606
2	Bullard® Hook Assembly	1	60160	60162	60164			60169
3	Top Yoke Half	2	C1FA005-90112SP	C1FA010-90112SP	C1FA015-90112SP			
4	Button Head Screw	2	9012612		9012602			
5	Flexloc® Nut**	2	9012613		9012604			
6	Warning Tag	1	WTAG6*					WTAG6*
7	Bullard® Bottom Hook Complete Set	1	6027801	6027802	6027803	6027805	6027807	6027808
8	Bullard® Hook Assembly	1	60160	60162	60164	60165	60168	60169
9	Bottom Yoke Half	2	C3BA005-90312SP	C3BA010-90312SP	C3BA015-90312SP			
10	Button Head Screw	4	9012612		9012602	9091274	9091296	
11	Flexloc® Nut**	4	9012613		9012604	ES857005S	ES066075	
12	Warning Tag*	1	WTAG6*					

*Hoist with Bullard® Hook(s) must have WTAG6 and WTAG9 installed. (See page 6 for WTAG9).

**See Table 6-3 in Owner's Manual for yoke nut torque specifications.

9.3 Optional Hooks

SmartLok™ Hooks*

Fig. No.	Name	Parts Per Hoist	1/2 Ton	1 Ton	1 1/2 Ton	2 Ton	3 Ton	5 Ton
1	SmartLok™ Top Hook Complete Set	1	60342	60343	60344			
6	Warning Tag	1	WTAG13**					
7	SmartLok™ Bottom Hook Complete Set	1	60321	60322	60323	60325	60327	60355
10	Button Head Screw	2				9091274	9091296	
11	Flexloc® Nut***	2				ES857005S	ES066075	
12	Warning Tag	1	WTAG13**					

* SmartLok™ Hook replaced Shur-loc® Hook offering in 2022.

**Hoist with SmartLok™ Hook(s) must have WTAG9 and WTAG13 installed. (See page 6 for WTAG9 and SmartLok Hook Supplement for WTAG13).

***See Table 6-3 in Owner's Manual for yoke nut torque specifications

Inspection Hooks

Fig. No.	Name	Parts Per Hoist	1/2 Ton	1 Ton	1 1/2 Ton	2 Ton	3 Ton	5 Ton
1	Top Hook Complete Set	1	M3001A005IK	M3001A010IK	M3001A015IK			
2	Hook W/Latch	1	C3BA005-20012	C3BA010-20012	C3BA015-20012			
3	Button Head Screw	2	9012612		9012602			
4	Flexloc® Nut*	2	9012613		9012604			
5	Top Yoke Half	2	C1FA005-20112SP	C1FA010-90112SP	C1FA015-90112SP			
6	Bottom Hook Complete Set	1	M3021A005IK	M3021A010IK	M3021A015IK			
7	Hook W/Latch	1	C3BA005-20012	C3BA010-20012	C3BA015-20012			
8	Button Head Screw	2	9012612		9012602			
9	Flexloc® Nut*	2	9012613		9012604			
10	Bottom Yoke Half	2	C3BA005-90312SP	C3BA010-90312SP	C3BA015-90312SP			

*See Table 6-3 in Owner's Manual for yoke nut torque specifications.

9.4 Optional Chain Containers

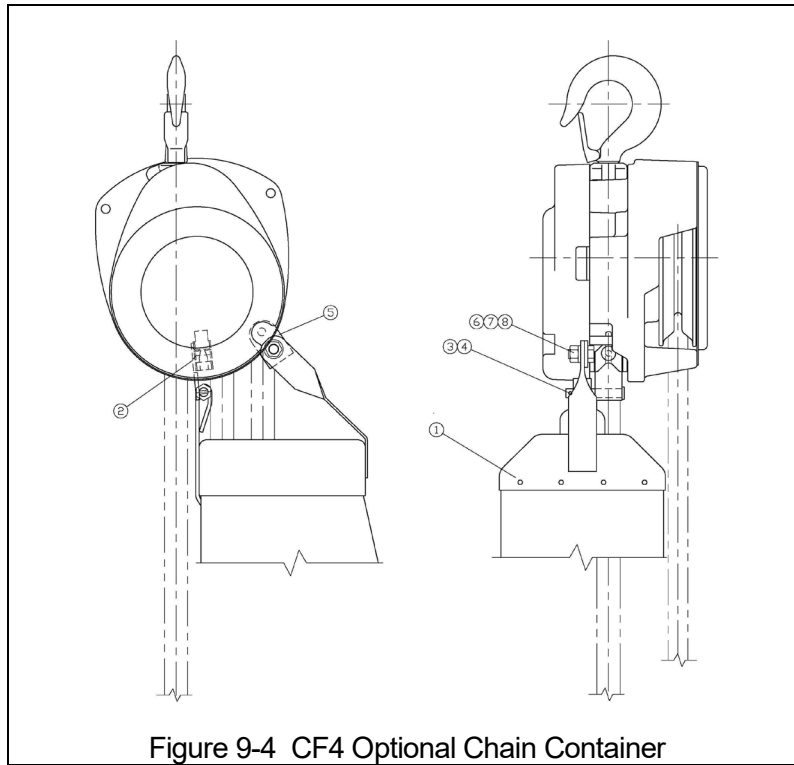


Figure 9-4 CF4 Optional Chain Container

CF4 OPTIONAL CHAIN CONTAINERS

Fig. No.	Name	Parts Per Hoist	1/2 Ton	1 Ton	1 1/2 Ton	2 Ton	3 Ton	5 Ton
	"05" Chain Container (BKC1) Assembly / Max Lift (ft)	1	60711 (39)	60713 (39)	60715 (28)	60713 (20)	60715 (14)	60715 (9)
1	Chain Container	1	50810	50810	50810	50810	50810	50810
2	Modified Stripper Assy	1	5078903	5076004	5080404	5076004	5080404	5080404
3	Split Pin	1	9009412	9009412	9009412	9009412	9009412	9009412
4	Washer	1	9005205	9005205	9005205	9005205	9005205	9005205
5	Link	1	5076005	5076005	5076005	5076005	5076005	5076005
6	Washer	2	9012513	9012513	9012513	9012513	9012513	9012513
7	Hex Head Bolt	1	9093327	9093328	9093328	9093328	9093328	9093328
8	Lock-Nut	1	9098506	9098506	9098506	9098506	9098506	9098506
	"10" Chain Container (BKD1) Assembly / Max Lift (ft)	1	60712 (68)	60714 (68)	60716 (49)	60714 (34)	60716 (24)	60716 (16)
1	Chain Container	1	5080403	5080403	5080403	5080403	5080403	5080403
2	Modified Stripper Assy	1	5078903	5076004	5080404	5076004	5080404	5080404
3	Split Pin	1	9009412	9009412	9009412	9009412	9009412	9009412
4	Washer	1	9005205	9005205	9005205	9005205	9005205	9005205
5	Link	1	5076005	5076005	5076005	5076005	5076005	5076005
6	Washer	2	9012513	9012513	9012513	9012513	9012513	9012513
7	Hex Head Bolt	1	9093327	9093328	9093328	9093328	9093328	9093328
8	Lock-Nut	1	9098506	9098506	9098506	9098506	9098506	9098506

⚠ WARNING Disassembly of hoist by a qualified individual is required to install the modified chain stripper for the chain container. The hoist must be load tested per ANSI/ASME B30.16 after re-assembly.

NOTES

NOTES

NOTES



Harrington Hoists, Inc.
401 West End Avenue
Manheim, PA 17545

www.harringtonhoists.com

Toll Free: 800-233-3010
Phone: 717-665-2000
Fax: 717-665-2861

© HARRINGTON HOISTS, INC.
ALL RIGHTS RESERVED

CFOM-ENG