Owner's Manual

MOTORIZED AIR TROLLEY MCR SERIES

¼ Ton through 6 Ton Capacity

Code and Serial Number

WARNING

This equipment should not be installed, operated or maintained by any person who has not read and understood all the contents of this manual. Failure to read and comply with the contents of this manual can result in serious bodily injury or death, and/or property damage.

HARRINGTON
A **KITO** GROUP COMPANY

IMPORTANT INFORMATION ON HOW TO USE THIS MANUAL

This OWNER'S MANUAL is intended for the MCR Air Trolley used with the TCR or TCK Air Hoist as a TCRM or TCKM model Air Trolley Hoist. No other hoist and trolley combinations are covered in this manual. References to the "Owner's Manual for the Air Powered Chain Hoist TCR/TCK Series" will be designated by the use of the acronym "TCROM" or "TCKOM".

Table of Contents

Section	Page Number
1.0 Important Information and Warnings.....	4
1.1 Terms and Summary	
1.2 Warning Tags and Labels	
2.0 Technical Information	8
2.1 Specifications	
2.2 Dimensions	
3.0 Pre-operational Procedures.....	10
3.1 Assembly and Adjustment	
3.2 Mounting Location	
3.3 Installation of Trolley onto Beam	
3.4 Air Connections	
3.5 Air Supply System Requirements	
3.6 Air Supply Capacity and Regulation	
3.7 Lubrication	
3.8 Filtration	
3.9 Air Dryer	
3.10 Piping, Hose and Fittings	
3.11 Connecting Trolley Hoist to Air Supply	
3.12 Pre-operational Checks and Trial Operation	

Section	Page Number
4.0	Operation..... 28
4.1	Introduction
4.2	Shall's and Shall Not's for Operation
4.3	Trolley and Hoist Controls
5.0	Inspection..... 31
5.1	General
5.2	Inspection Classification
5.3	Frequent Inspection
5.4	Periodic Inspection
5.5	Occasionally Used Trolleys
5.6	Inspection Records
5.7	Inspection Methods and Criteria
6.0	Maintenance & Handling..... 37
6.1	Air Trolley Motor Lubrication
6.2	Air Trolley Lubrication
6.3	Brake
6.4	Storage
6.5	Outdoor Installation
7.0	Troubleshooting..... 39
8.0	Warranty..... 40
9.0	Parts List..... 41

1.0 Important Information and Warnings

1.1 Terms and Summary

This manual provides important information for personnel involved with the installation, operation and maintenance of this product. Although you may be familiar with this or similar equipment, it is strongly recommended that you read this manual before installing, operating or maintaining the product.

Danger, Warning, Caution and Notice - Throughout this manual there are steps and procedures that can present hazardous situations. The following signal words are used to identify the degree or level of hazard seriousness.

⚠ DANGER Danger indicates an imminently hazardous situation which, if not avoided, **will** result in **death or serious injury**, and property damage.

⚠ WARNING Warning indicates an imminently hazardous situation which, if not avoided, **could** result in **death or serious injury**, and property damage.

⚠ CAUTION Caution indicates a potentially hazardous situation which, if not avoided, **may** result **minor or moderate injury** or property damage.

NOTICE Notice is used to notify people of installation, operation, or maintenance information which is important but not directly hazard-related.

⚠ CAUTION

These general instructions deal with the normal installation, operation, and maintenance situations encountered with the equipment described herein. The instructions should not be interpreted to anticipate every possible contingency or to anticipate the final system, crane, or configuration that uses this equipment. For systems using the equipment covered by this manual, the supplier and owner of the system are responsible for the system's compliance with all applicable industry standards, and with all applicable federal, state and local regulations/codes.

This manual includes instructions and parts information for a variety of trolley and hoist types. Therefore, all instructions and parts information may not apply to any one type or size of specific trolley or hoist. Disregard those portions of the instructions that do not apply.

Record your trolley's Code and Serial Number on the front cover of this manual for identification and future reference to avoid referring to the wrong manual for information or instructions on installation, operation, inspection, maintenance, or parts.

Use only Harrington authorized replacement parts in the service and maintenance of this trolley.

WARNING

Equipment described herein is not designed for and **MUST NOT** be used for lifting, supporting, or transporting people, or for lifting or supporting loads over people.

Equipment described herein should not be used in conjunction with other equipment unless necessary and/or required safety devices applicable to the system, crane, or application are installed by the system designer, system manufacturer, crane manufacturer, installer, or user.

Modifications to upgrade, rerate, or otherwise alter this equipment shall be authorized only by the original equipment manufacturer.

Equipment described herein may be used in the design and manufacture of cranes or monorails. Additional equipment or devices may be required for the crane and monorail to comply with applicable crane design and safety standards. The crane designer, crane manufacturer, or user is responsible to furnish these additional items for compliance. Refer to ANSI/ASME B30.17, "Safety Standard for Top-Running Single Girder Cranes"; ANSI/ASME B30.2 "Safety Standard for Top-Running Double-Girder Cranes"; and ANSI/ASME B30.11 "Safety Standard for Underhung Cranes and Monorails".

If a below-the-hook lifting device or sling is used with a hoist, refer to ANSI/ASME B30.9, "Safety Standard for Slings" or ANSI/ASME B30.20, "Safety Standard for Below-the-Hook Lifting Devices".

Hoists, trolleys and cranes, used to handle hot molten material may require additional equipment or devices. Refer to ANSI Z241.2, "Safety Requirements for Melting and Pouring of Metals in the Metalcasting Industry".

Failure to read and comply with any one of the limitations noted herein can result in serious bodily injury or death, and/or property damage.



DANGER

HAZARDOUS AIR PRESSURE IS PRESENT IN THE HOIST, IN THE SUPPLY OF COMPRESSED AIR TO THE HOIST, AND IN THE CONNECTIONS BETWEEN COMPONENTS.

Before performing ANY maintenance on the equipment, de-energize the supply of compressed air to the equipment, and lock and tag the supply device in the de-energized position. Refer to ANSI Z244.1, "Personnel Protection - Lockout/Tagout of Energy Sources."

Only trained and competent personnel should inspect and repair this equipment.

NOTICE

It is the responsibility of the owner/user to install, inspect, test, maintain, and operate a trolley or hoist in accordance with ANSI/ASME B30.16, "Safety Standard for Overhead Hoists", OSHA Regulations. If the trolley is installed as part of a total lifting system, such as an overhead crane or monorail, it is also the responsibility of the owner/user to comply with the applicable ANSI/ASME B30 volume that addresses that type of equipment.

It is the responsibility of the owner/user to have all personnel that will install, inspect, test, maintain, and operate a hoist read the contents of this manual and applicable portions of ANSI/ASME B30.16, "Safety Standard for Overhead Hoists" and OSHA Regulations. If the trolley is installed as part of a total lifting system, such as an overhead crane, the applicable ANSI/ASME B30 volume that addresses that type of equipment must also be read by all personnel.

If the trolley owner/user requires additional information, or if any information in the manual is not clear, contact Harrington or the distributor of the trolley. Do not install, inspect, test, maintain, or operate this trolley unless this information is fully understood.

A regular schedule of inspection of the trolley in accordance with the requirements of ANSI/ASME B30.16 should be established and records maintained.

1.2 Warning Tag and Labels

The warning tag illustrated below in Figure 1-1 is supplied with each trolley shipped from the factory. If the tag is not attached to the pendant cord for your hoist/trolley, order a tag from your dealer and install it. Read and obey all warnings attached to this trolley. Tag is not shown actual size.

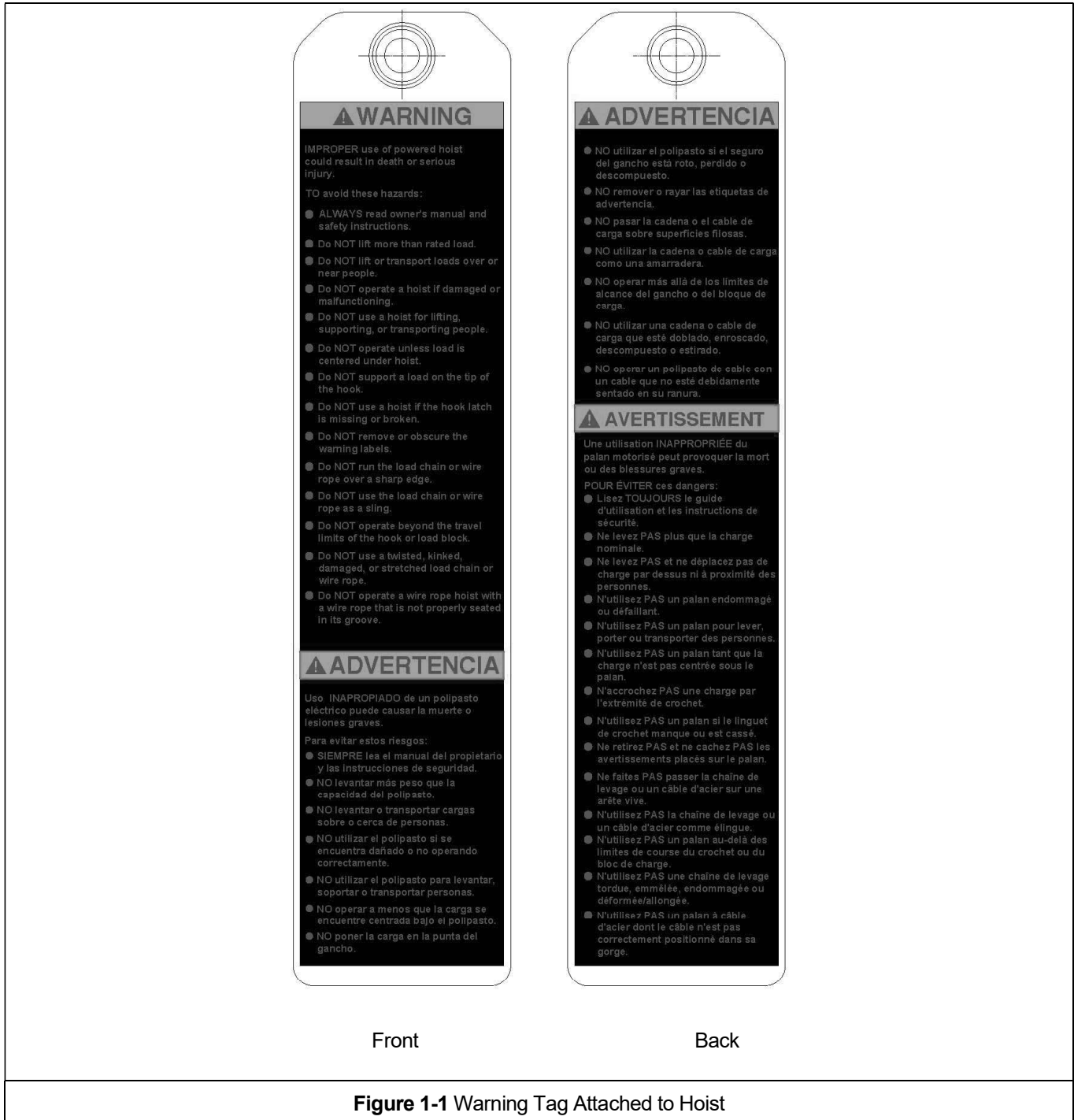

2.0 Technical Information

2.1 Specifications

2.1.1 Product Code for MCR Trolley Alone:

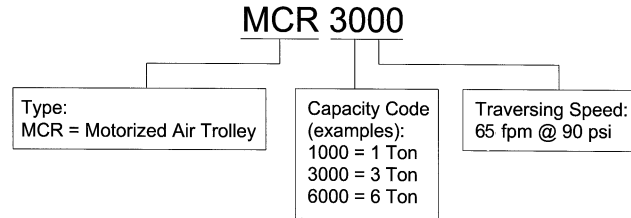

2.1.2 Product Code for MCR Air Trolley with TCR or TCK Series Air Hoist:

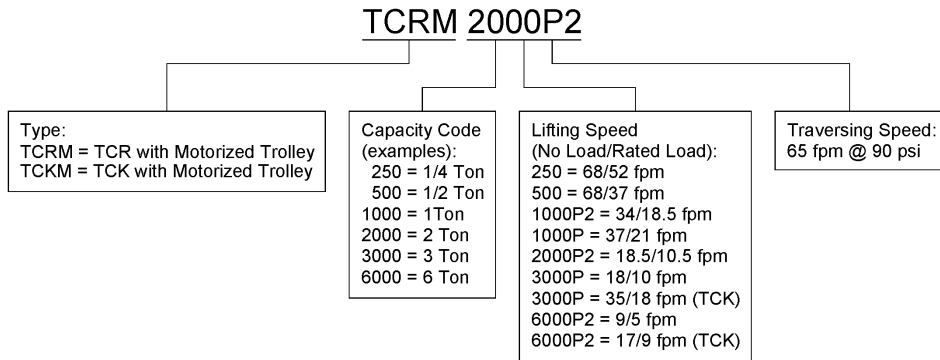

Table 2-1 Trolley Hoist Specifications

Cap. (Tons)	MCR Product Code	TCRM/TCKM Product Code	Standard Lift (ft)	Push Button Cord L (ft)	TCR/TCK Lifting/Lowering Speeds (ft/min)		90 psi Traversing Speed (ft/min)	TCR/TCK Air Consumption Rates (cubic ft/min)			MCR Flange Width Adjustability B (in)	MCR Minimum Allow. Radius for Curve (in)	TCR Load Chain Diameter (mm) x Chain Fall Lines	Net Weight (lbs)	Weight for Additional One Foot of Lift (lbs)
					90 psi Lifting / Lowering			90 psi Lifting / Lowering		MCR					
					No Load	w/Rated Load		No Load	w/Rated Load						
										TCR/TCK					
1/4	MCR1000	TCRM250P	10	7.4	68 / 44	37 / 57	65	63 / 49	48 / 57	53	2.28 to 5.00	137.8	6.3 x 1	181	0.6
1/2		TCRM500P													
1		TCRM1000P2													
1		TCRM1000P													
2	MCR3000	TCRM2000P2	10	7.4	18.5 / 11	10.5 / 16.5	65	62 / 53	53 / 60	53	3.94 to 6.02	51.2	7.1 x 2	232	1.5
3		TCRM3000P													
		TCKM3000P													
6	MCR6000	TCRM6000P2	10	7.4	9 / 5.5	5 / 7.5	65	90 / 65	71 / 74	53	4.92 to 7.02	78.7	11.2 x 2	388	4.0
		TCKM6000P2													

2.1.3 Operating Conditions and Environment

Temperature Range: +14° to +140°F (-10° to +60°C)

Humidity: 85% or less

Supply Air: 60 or 90 psi

2.2 Dimensions

Table 2-2 Trolley Hoist Dimensions																
Cap. (Tons)	Product Code	Headroom C (in)	b (in)	b' (in)	d (in)	e (in)	e' (in)	g (in)	i (in)	j (in)	k (in)	m (in)	n (in)	r (in)	t (in)	
1/4	TCRM250P	19.3	12.4	15.6	10.3	6.2	3.7	1.3	3.7	0.9	4.8	4.6	4.4	2.1	1.2	
1/2	TCRM500P															
1	TCRM1000P2	21.5	13.4	17.4	10.5	6.9	3.9	1.6	4.9	1.4	5.0	5.1	5.5	2.8	1.7	
1	TCRM1000P	19.5														
2	TCRM2000P2	22.2														
3	TCRM3000P	21.8														
6	TCRM6000P2	25.3	15.7	19.8	10.8	8.1	4.3	2.0	5.5	5.5	5.7	6.1	3.9	2.3		
	TCKM3000P	29.5						1.3								
	TCKM6000P2	34.1						1.7								

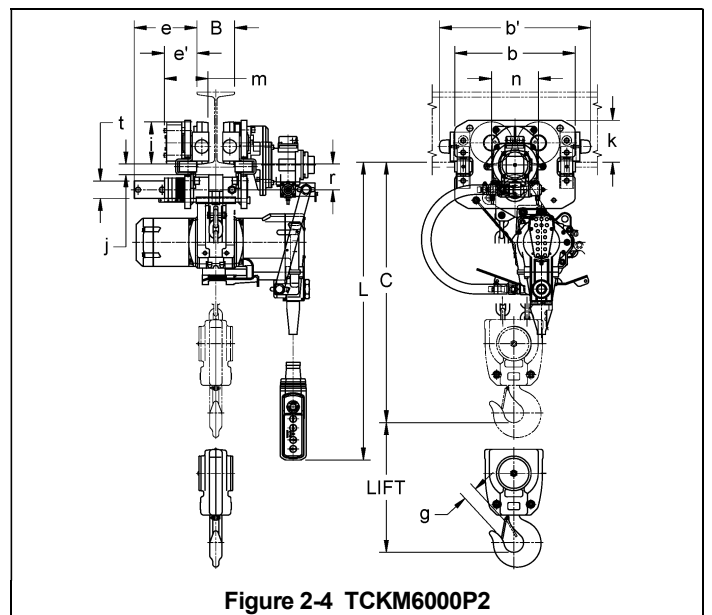
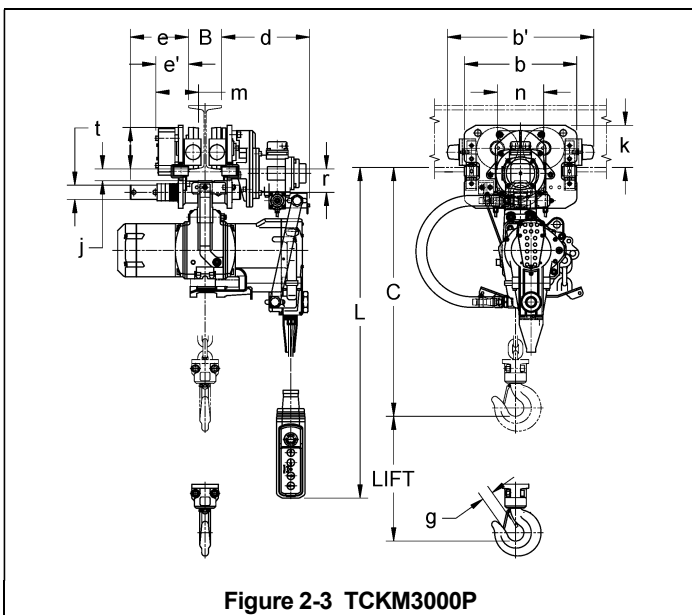
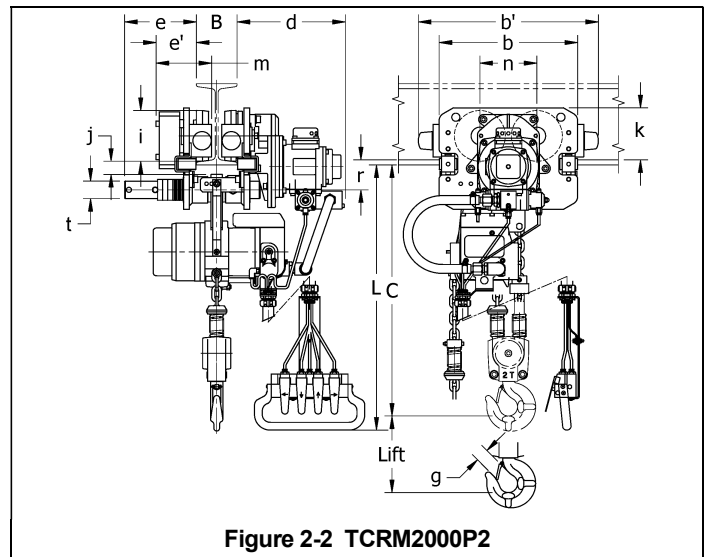
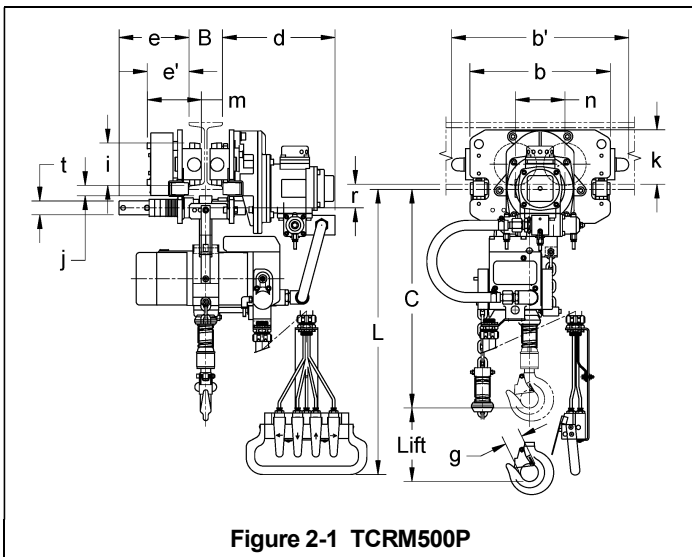

3.0 Pre-operational Procedures

3.1 Assembly and Adjustment

3.1.1 When the MCR trolley is combined with a hoist, follow and complete all pre-operational procedures provided with the hoist. For Harrington TCR and TCK model hoists, follow the pre-operational procedures in the respective TCR or TCK Owner's Manual in conjunction with all information provided in this section for mounting and air hose connections.

3.1.2 In addition to the information and procedures provided in this section for the MCR trolley, there are specific details for using TCR and TCK hoists with MCR trolleys. Special mounting and air hose considerations must be taken if the trolley is used with a hoist other than a TCR or TCK model.

3.1.3 **⚠ WARNING** Never attempt to hook mount a hoist directly to the Suspension Shaft on air trolleys. These trolleys are designed to be used with a suspender only.

3.1.4 Preparing TCR and TCK hoists for use with MCR trolley.

For Single fall hoists (TCR250P, 500P, 1000P, 3000P, TCK3000P)

Remove the Top Hook Assembly from the hoist and install the suspender as follows:

- 1) Refer to Figure 3-1.
- 2) Remove the top pin, yoke and top hook.
- 3) To remove the top pin, yoke and top hook on the TCR1000P loosen and remove the 3 bolts holding the gear section onto the main body. Rotate the gear section clockwise to allow the top pin to be removed.
- 4) Place the suspender on the top of the hoist. Line up the holes for the hoist main body and suspender. Reinsert the top pin.
- 5) Reassemble the remaining hoist components in reverse order of disassembly.

For Double fall hoists (TCR1000P2, 2000P2, 6000P2, TCK6000P2)

Remove the Top Hook Assembly and Load Chain from the hoist and install the suspender as follows:

- 1) Refer to Figure 3-2.
- 2) Loosen and remove the bolt attaching the load chain to the top hook yoke.
- 3) Remove the load chain from the top hook yoke.
- 4) Remove the top pin, yoke and top hook.
- 5) To remove the top pin, yoke and top hook on the TCR2000P2 loosen and remove the 3 bolts holding the gear section onto the main body. Rotate the gear section clockwise to allow the top pin to be removed.
- 6) Place the suspender on the top of the hoist. Line up the holes for the hoist main body and suspender. Reinsert the top pin.
- 7) Reassemble the remaining hoist components in reverse order of disassembly
- 8) Reattach the no load side of the load chain to the load chain mounting hole in the suspender.

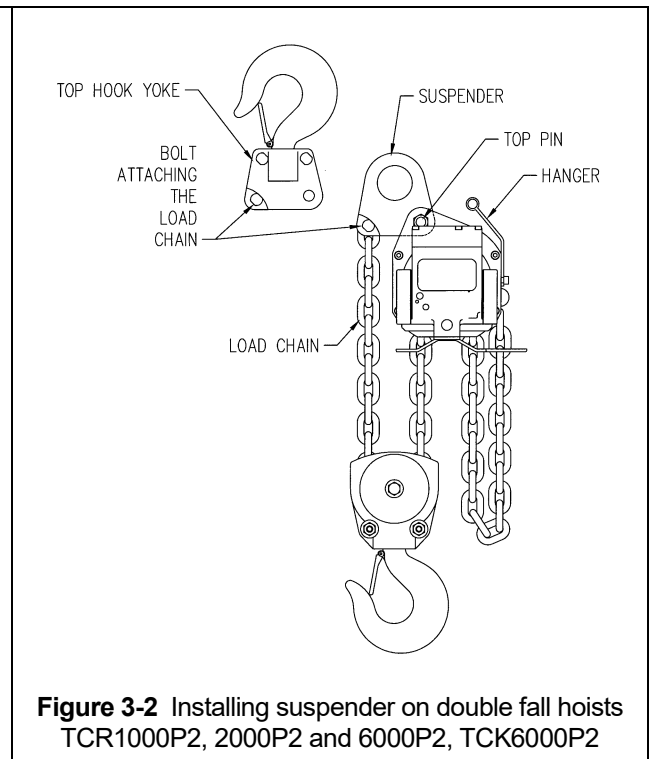
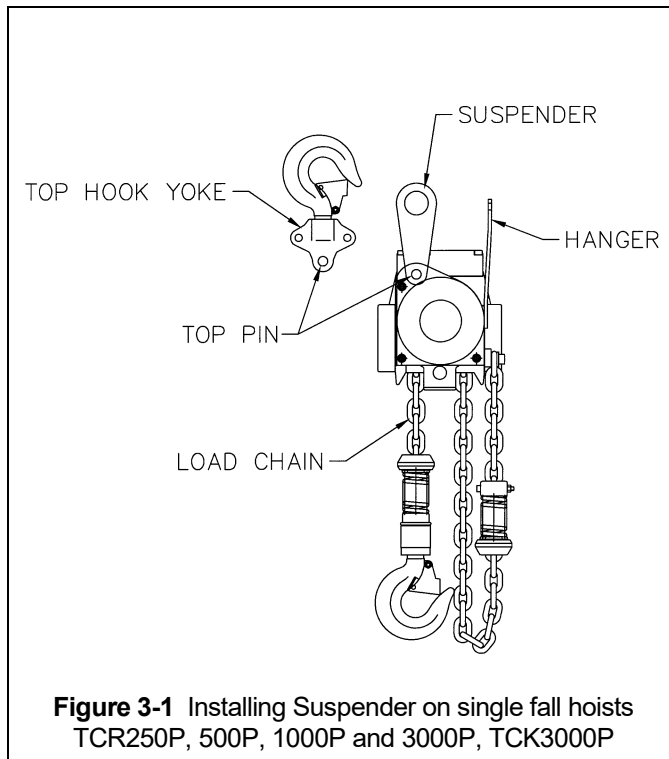

3.1.5 Trolley Assembly

- 1) Refer to Figure 3-5.
- 2) Remove the Shaft Stopper Pin, Side Plate S (counterweight side), and Spacers from the Suspension Shaft. Refer to Table 3-1.
- 3) Insert the Suspension Shaft to Side Plate G (motor side) and attach it with the Suspension Shaft Bolt, Slotted Nut and Split Pin (cotter pin). Refer to Figure 3-4 and insure that correct Suspension Shaft holes are used. Securely bend both branches of the Split Pin after insertion.
- 4) Referring to Figure 3-5, Table 3-1 and Table 3-2 install the inner adjusting Spacers and Suspender (with hoist) on the Suspension Shaft. Use all of the Spacers provided with the trolley. If the beam width is not listed in Table 3-2, use the next size smaller and make adjustments in accordance with Section 3.1.6.
- 5) Place Side Plate S into the Suspension Shaft.
- 6) Install the outer adjusting Spacers on the Suspension Shaft outside of Side Plate S. Insert the Shaft Stopper Pin into Hole "A" so that Split Pin is to the left when seen from the front side of trolley switch box. Temporarily install the split pin in the Shaft Stopper Pin and bend the split pin slightly to hold it in place. The split pin should be fully bent after checking and attaining the proper beam flange adjustment.

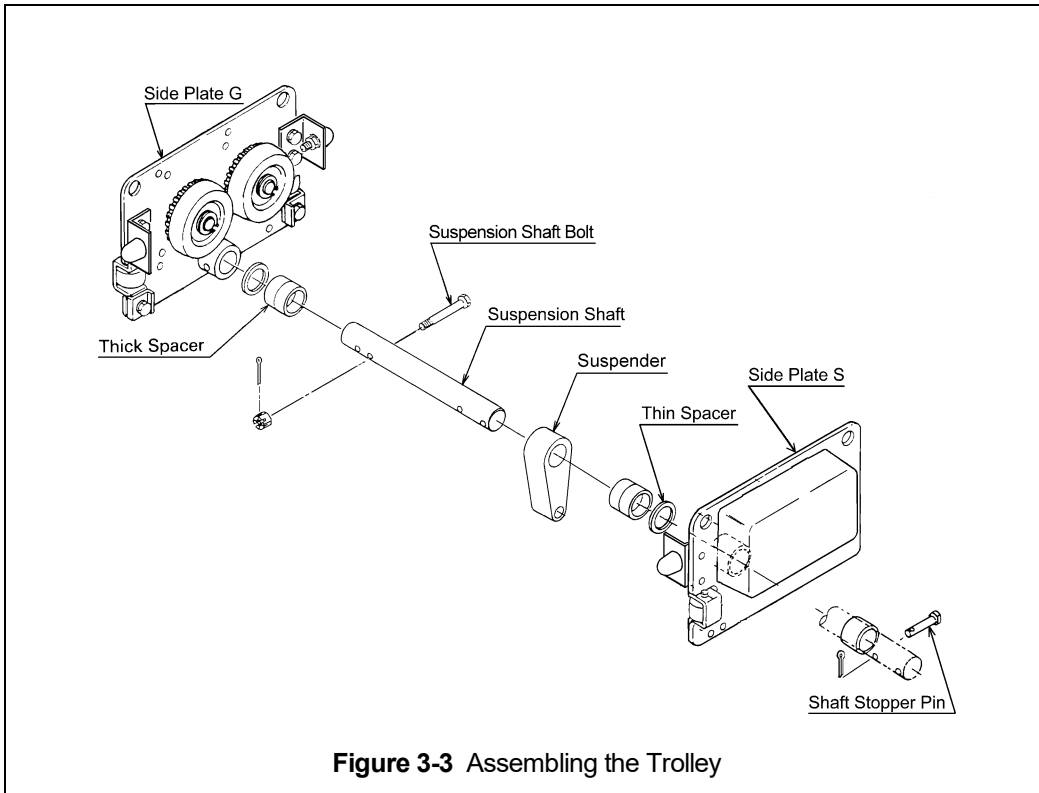
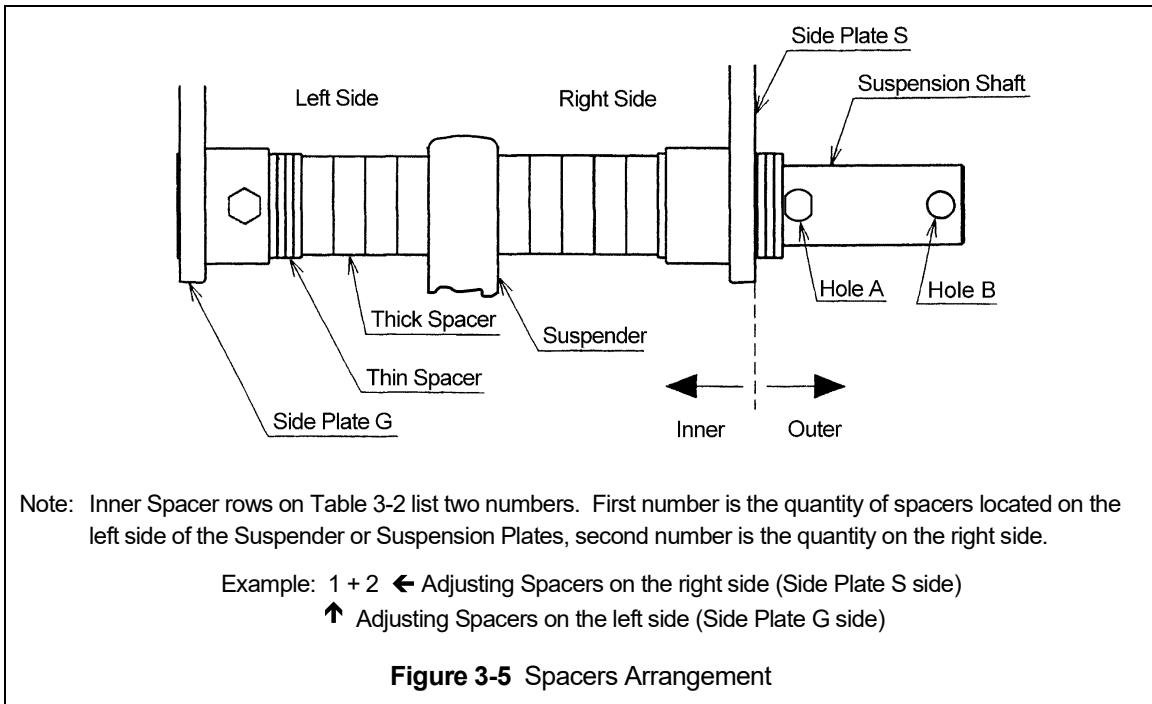
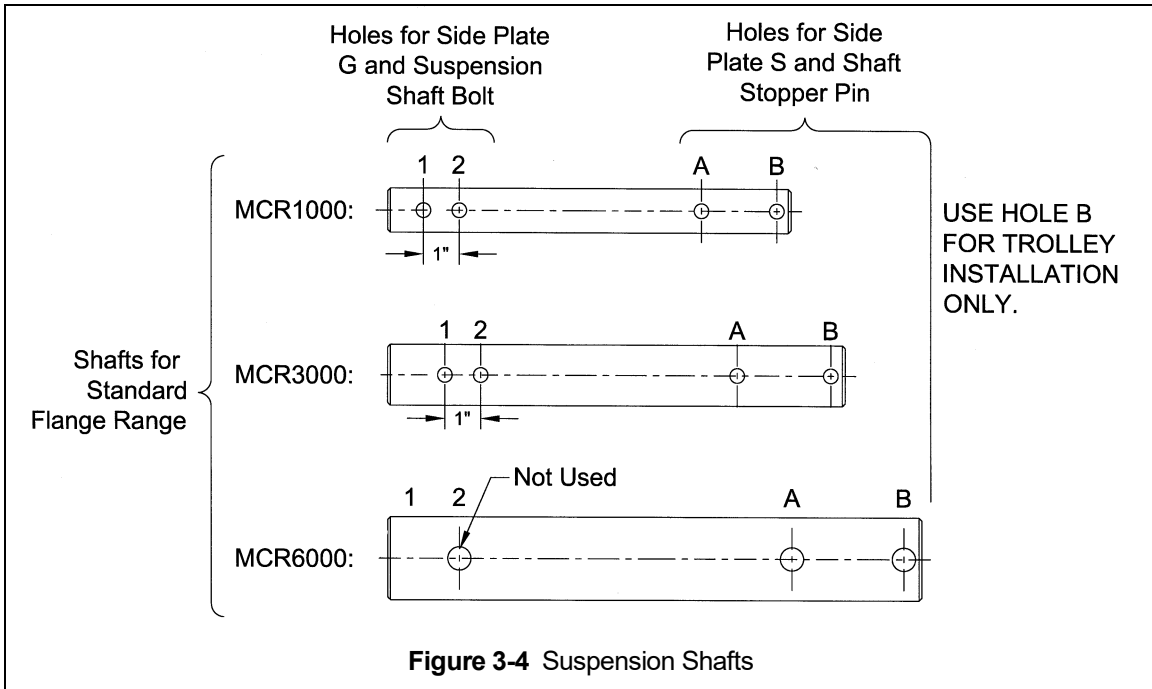

Figure 3-3 Assembling the Trolley

Table 3-1 Suspension Shaft Adjusting Spacers, and Suspension Shaft Bolt				
Product Code	Flange Range (in)	Total Number of Spacers Supplied		Suspension Shaft Bolt Location
		Thin	Thick	
MCR1000	2.28 to 5.00	8	5	Hole 2
MCR3000	3.94 to 6.02	8	3	Hole 2
MCR6000	4.92 to 7.02	8	3	Hole 2



3.1.6 Adjusting the trolley width – After assembling trolley per Section 3.1.5, check the adjustment as follows:

- 1) Refer to Figure 3-6.
- 2) Make sure both side plates are spread fully outward and Measure Dimension "A". Compare dimension "A" with the following values:
 - For MCR1000 trolleys, "A" must be 1/8 to 3/16" greater than "B".
 - For MCR3000 and MCR6000, "A" must be 7/32 to 9/32" greater than "B".
- 3) If "A" does not fall within the specified range, move spacers from inner to outer or from outer to inner as necessary to obtain the proper "A" dimension, irrespective of the numbers in Table 3-2.
- 4) After obtaining the proper adjustment, install the Shaft Stopper Pin in Hole A, insert the Split Pin into the Shaft Stopper Pin, and securely bend both branches of the split pin.

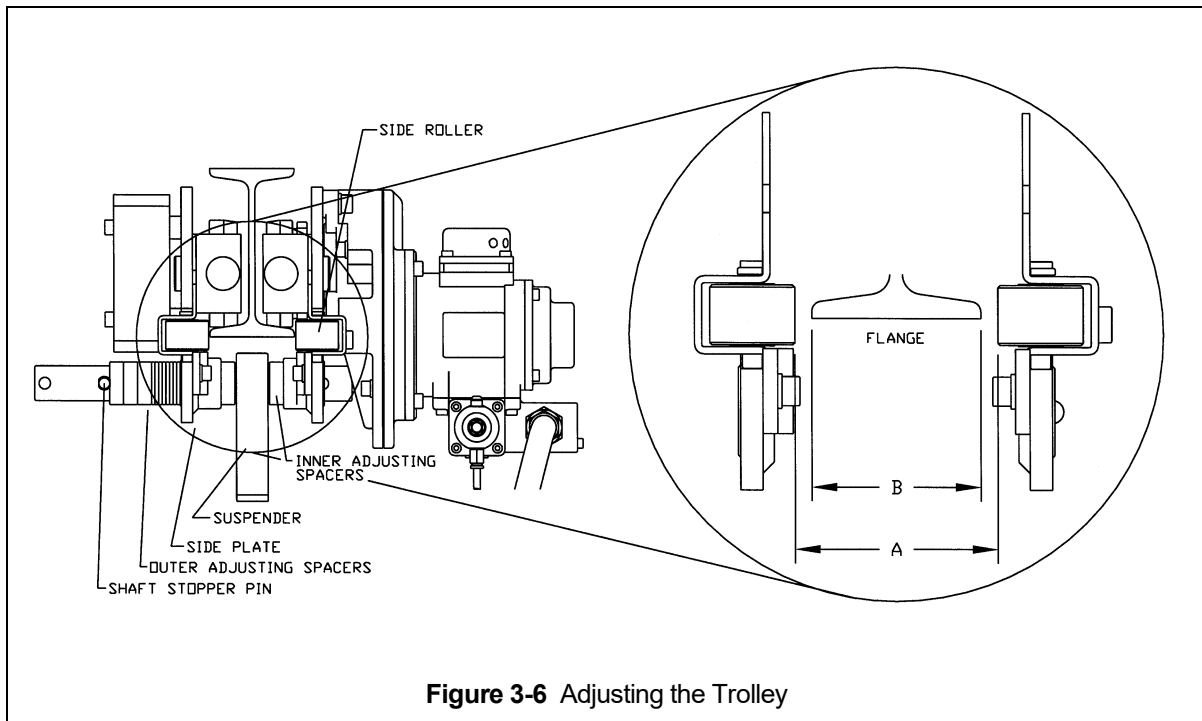

3.1.7 Attaching the Hangar Bracket and Hangar.

For TCR on MCR1000 and MCR3000 Trolleys

- 1) Refer to Figure 3-7.
- 2) Attach the Hangar Bracket to the Side Plate with the hardware provided.
- 3) Attach the Hangar to the Hangar Bracket with the hardware provided.
- 4) Attach the Hangar to the hoist with the hardware provided.

For TCR on MCR6000 Trolley

- 1) Refer to Figure 3-7.
- 2) Attach the Hangar to the hoist with the hardware provided.
- 3) Slide the Hangar Bracket through hole in Side Plate S (counterweight side), through the Hangar and into the hole in Side Plate G.
- 4) Slide the Split Pin provided into the hole in the hangar on the (outside of Side Plate G).
- 5) Bend the Split Pin appropriately.

For TCK on MCR3000 Trolley

- 1) Refer to Figure 3-8.
- 2) Attach the Hangar Bracket to the Side Plate with the hardware provided.
- 3) Attach the Hangar to the Hangar Bracket with the hardware provided.
- 4) Attach the Hangar to the hoist with the hardware provided.

For TCK on MCR6000 Trolley

- 1) Refer to Figure 3-8.
- 2) Attach the Hangar to the hoist with the hardware provided.
- 3) Slide the Hangar Bracket through hole in Side Plate S (counterweight side), through the Hangar and into the hole in Side Plate G.
- 4) Slide the Split Pin provided into the hole in the hangar on the (outside of Side Plate G).
- 5) Bend the Split Pin appropriately.

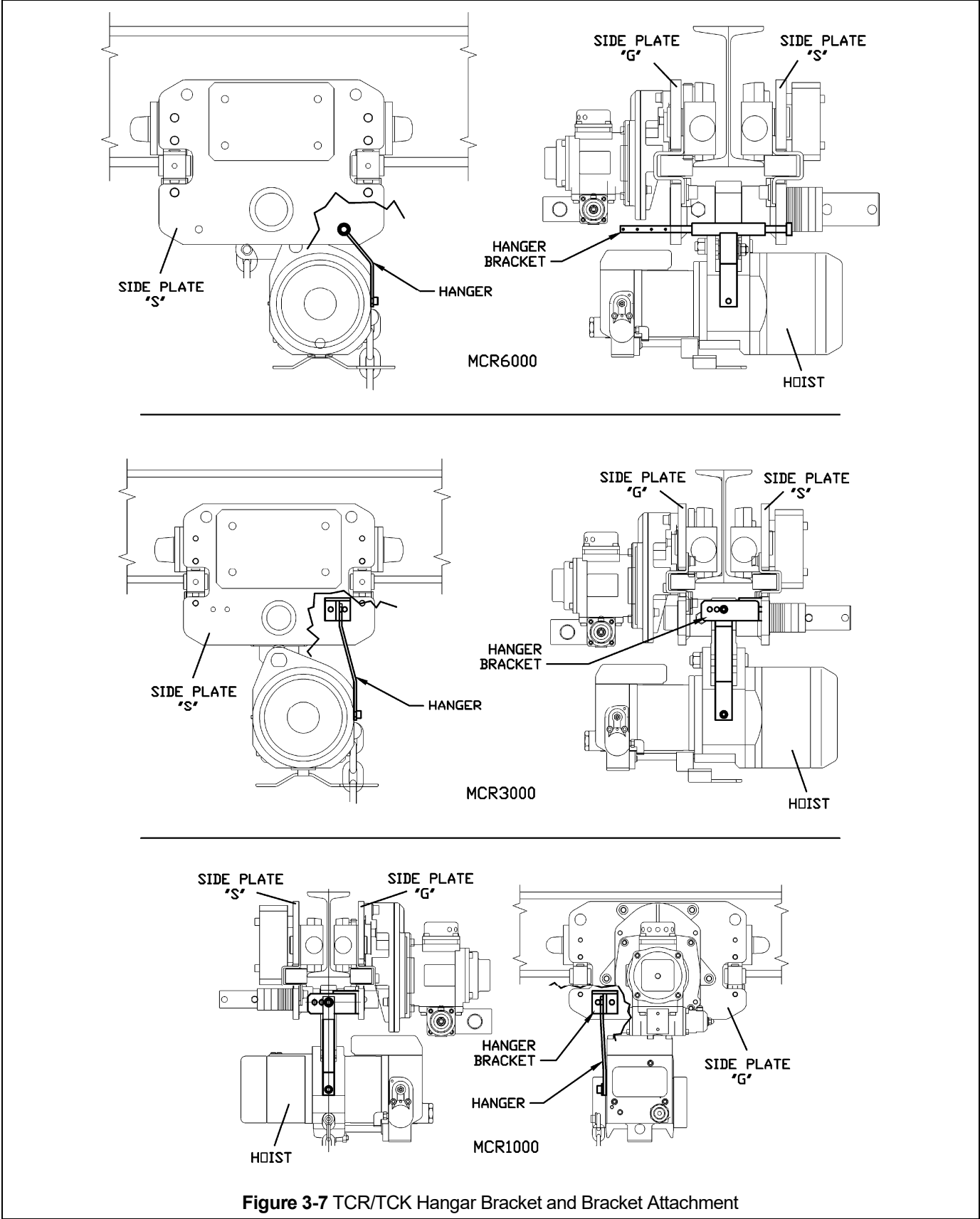

Figure 3-7 TCR/TCK Hanger Bracket and Bracket Attachment

3.2 Mounting Location

3.2.1 **⚠ WARNING** Prior to mounting the trolley (and hoist) ensure that the trolley beam and its supporting structure are adequate to support the trolley, hoist and its loads. If necessary consult a professional that is qualified to evaluate the adequacy of the suspension location and its supporting structure.

3.2.2 **NOTICE** See Section 6.5 for outdoor installation considerations.

3.3 Installation of Trolley onto Beam

3.3.1 Assemble and adjust the trolley before attempting to install the trolley on the beam.

3.3.2 Preferred Method – Sliding the trolley connected with the air chain hoist onto the traversing beam from the beam end is the most convenient and recommended method. If the trolley can be mounted from the end of the beam then: Remove the trolley end-stop from the beam and set the trolley on the beam from the end. Securely re-install the trolley end stop on the beam.

3.3.3 Optional Method – If the trolley cannot be mounted from the end of the beam, complete the installation as follows:

- 1) Move the Shaft Stopper Pin to Hole B (see Figure 3-8).
- 2) Spread the trolley side plates apart.
- 3) Lift the trolley onto the beam so that the geared wheels (motor side of trolley) rest on the beam's flange.
- 4) Hold Side Plate G securely so that it does not come off the beam then push the side plates together so that all four wheels rest on the beam's flange.
- 5) Remove the Shaft Stopper Pin from Hole B and re-install in Hole A (see Figure 3-4). Bend the Split Pin securely. Never use trolley with Shaft Stopper Pin in Hole B. Hole B is ONLY used when installing the trolley on the beam.

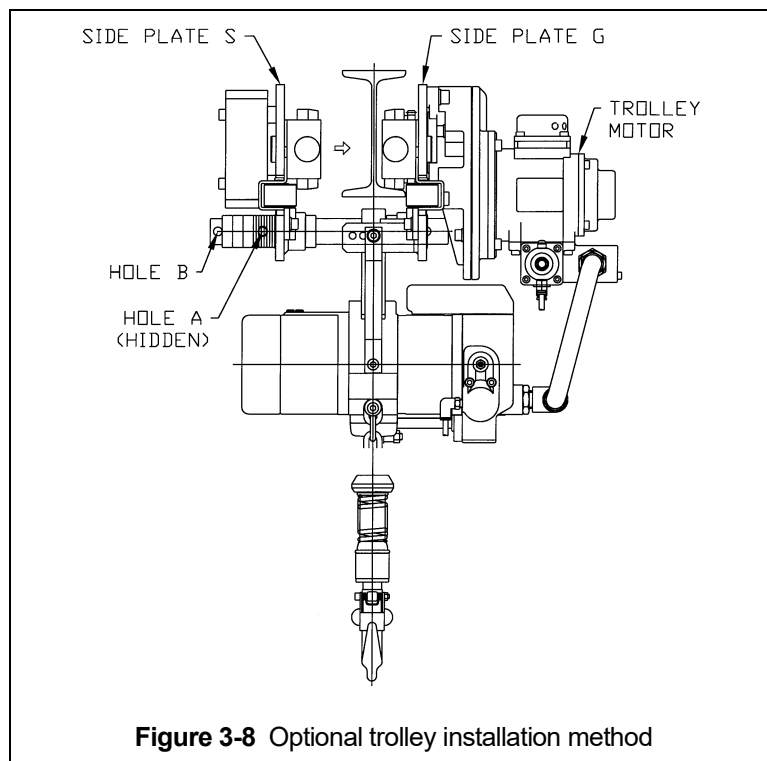

3.4 Air Connections

- 3.4.1 **⚠ CAUTION** Ensure that the air supply pressure and volume is proper for the hoist or trolley.
- 3.4.2 **⚠ DANGER** Before proceeding, ensure that the air supply for the hoist or trolley has been de-energized (disconnected). Lock out and tag out in accordance with ANSI Z244.1 “Personnel Protection -Lockout/Tagout of Energy Sources”.
- 3.4.3 This instruction applies to installations where a TCR or TCK model air hoist is installed on an MCR trolley. In this case the hoist and trolley are controlled by a pendant with four levers or push buttons – two for the hoist motion and two for the trolley motion. Special air hose considerations must be taken if the trolley is used with a hoist other than a TCR or TCK model.

Trolley to Hoist Air Hose Connection – The Trolley Hoist Air Hose connects directly to the air fittings on the trolley and on the hoist. Make these connections as follows:

- 1) Refer to Figure 3-9 for TCR connections, and Figure 3-10 for TCK connections.
- 2) Insert one end of the air hose into the trolley barbed air fitting until fully seated. Tighten the hose clamp.
- 3) Insert the other end of the air hose into the hoist barbed air fitting until fully seated. Tighten the hose clamp.

Pendant Assembly Connection – The Pendant Assembly connects to the trolley via 3 air hoses and to the hoist via 3 air hoses. Make these connections as follows:

- 1) Refer to Figure 3-9 for TCR connections, and Figure 3-10 for TCK connections.
- 2) Attach the pendant assembly to the hoist by attaching the under cover bracket to the hoist with screws.
- 3) Attach the pendant assembly strain relief to the mounting screw on the hoist.
- 4) Insert the pendant assembly air hoses into the proper fittings on the trolley and the hoist. For TCR connections, follow the hose colors shown in Figure 3-9. TCK pendant hoses are labeled by function (U=Up, D=Down, E=Emergency Stop, L=Left, R=Right). Ensure that the hoses are fully seated on the barbed fitting and the hose clamps are tightened.

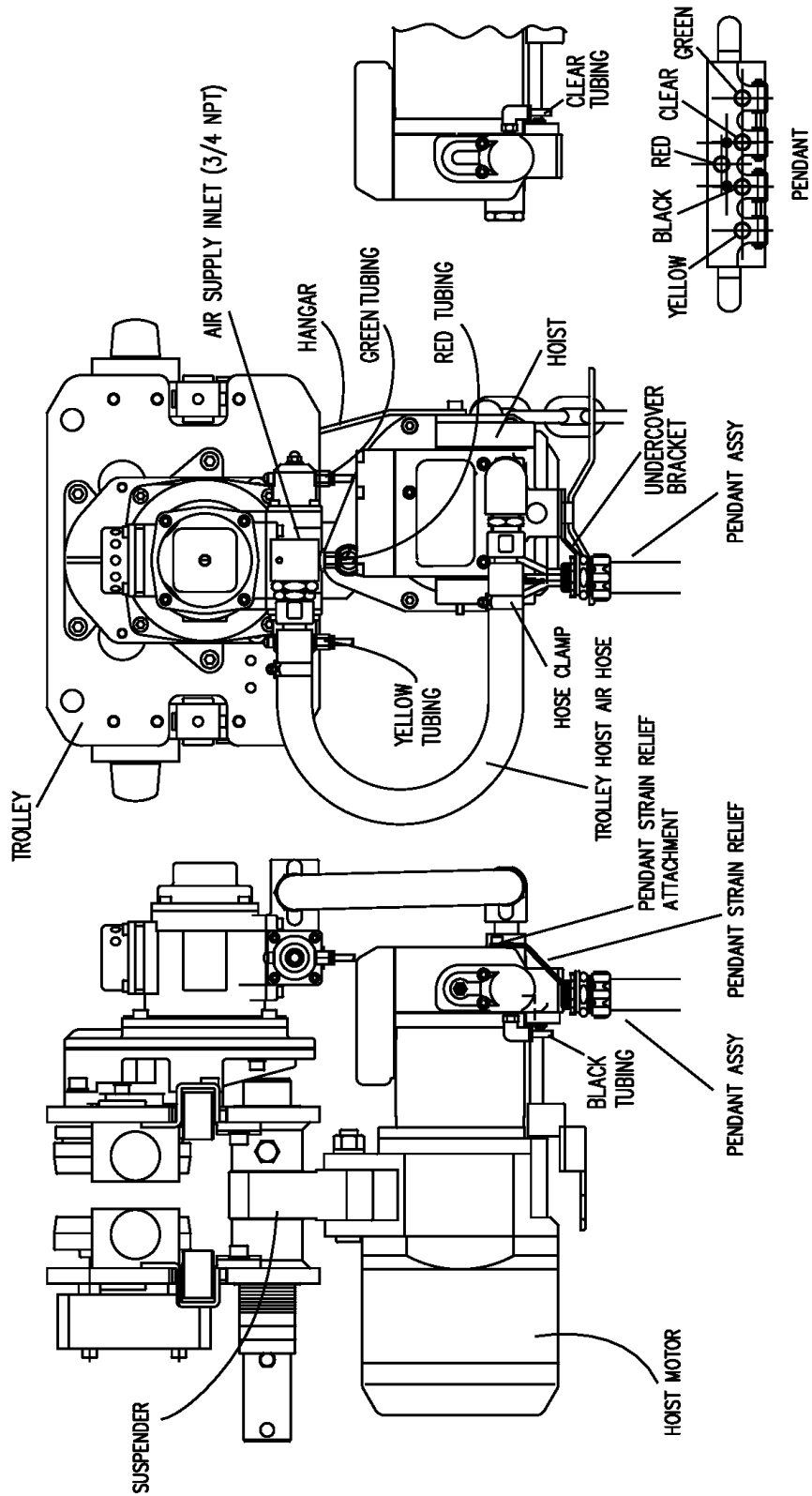

Figure 3-9 TCR Air Supply and Pendant Hose Connections

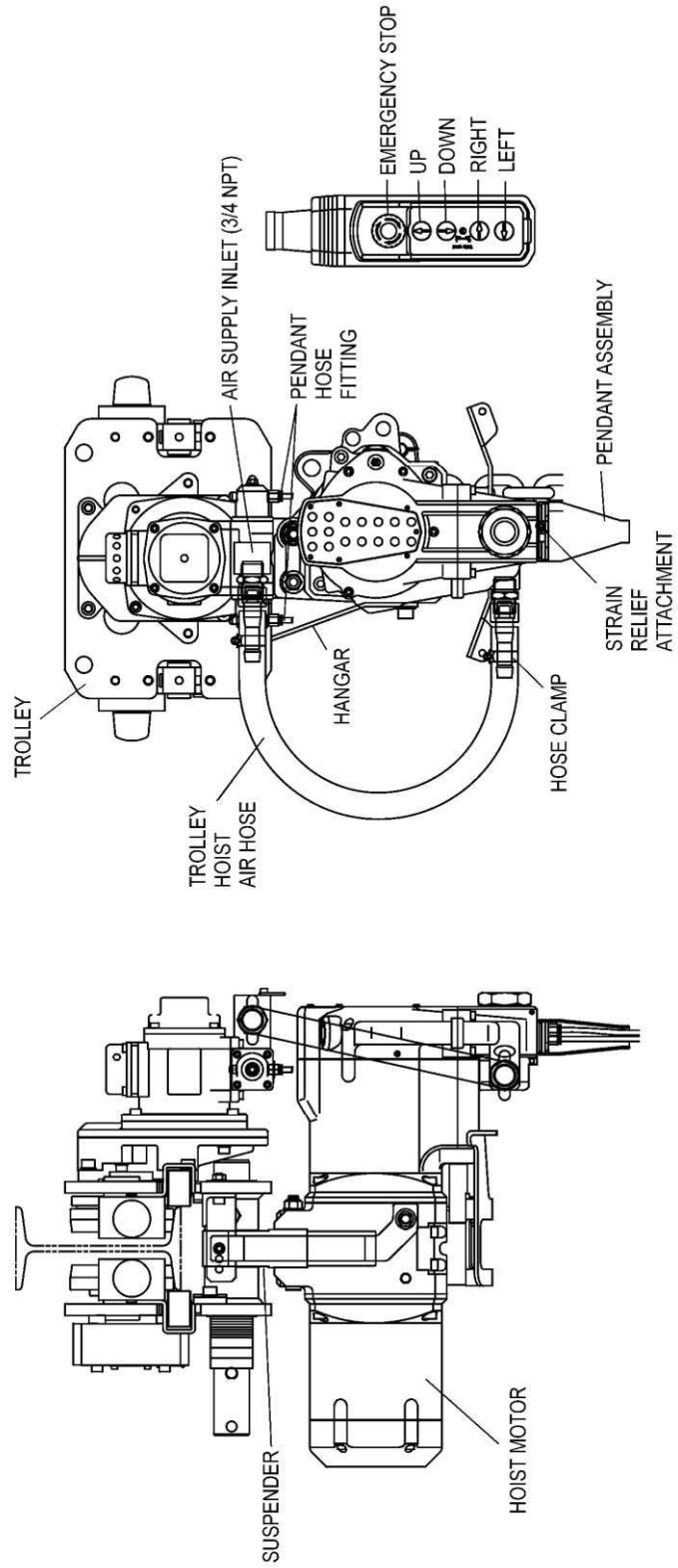

Figure 3-10 TCK Air Supply and Pendant Hose Connections

3.5 Air Supply System Requirements

- 3.5.1 **NOTICE** Pressure and Flow – Verify that the air supply system has capacity to supply your air trolley hoist with required pressure and flow. Otherwise the hoist may operate poorly or may fail to operate. See Section 3.6.
- 3.5.2 **CAUTION** Lubrication – The trolley hoist requires lubrication for proper operation. The oil in the air supply is the primary source of lubrication to the hoist. Therefore, a dedicated air supply lubricator must be used with the trolley hoist. Refer to Section 3.7.
- 3.5.3 **CAUTION** Air Quality – Good air quality is essential to prevent damage to your trolley hoist and to ensure its proper operation. The air must be clean and free of debris such as dirt and rust. Refer to Section 3.8 for filtration requirements. The air must also be dry; free of moisture and water. Refer to Section 3.9.

3.6 Air Supply Capacity And Regulation

- 3.6.1 Capacity – The air supply system must be capable of delivering the required airflow (cfm) to the trolley air supply inlet port. Without the required airflow the hoist will not operate properly or may not operate at all. See Section 2.0 for your trolley hoist air consumption requirements. In determining if your system is capable of supplying the required airflow, consider the following:
- Capacity of compressor(s) and tank
 - Other air consuming equipment
 - Flow restrictions such as pipes, hoses, valves and fittings
- Inadequate capacity will cause a significant drop in pressure when the hoist or trolley is operated, and could cause poor performance or failure to operate.
- 3.6.2 Regulation – The trolley hoist requires a constant supply of air at a pressure of between 60 and 90 psi. If the air supply is not regulated or is regulated at a pressure greater than 90 psi, then a regulator must be used. The regulator may be located anywhere upline of the lubricator in the air supply to the hoist.

3.7 Lubrication

- 3.7.1 **CAUTION** The trolley hoist must be supplied with its own lubricator. The lubricator must be located as follows:
- 1) **Best location** – At the trolley inlet. In this case the lubricator can be either the mist type or drop type.
 - 2) **Second best location** – No more than 15 feet away from the trolley hoist, at the same elevation or above the trolley inlet. In this case the mist type lubricator must be used.
 - 3) **Third best location** – No more than 15 feet away below the trolley hoist. In this case the mist type lubricator must be used.
- 3.7.2 **CAUTION** The lubricator must be set to deliver the equivalent of 10 to 15 drops of oil per minute (0.2 to 0.3 cc/minute). The hoist and trolley exhaust will emit a fine oil mist when properly lubricated.

3.8 Filtration

3.8.1 **⚠ CAUTION** The air entering the trolley inlet must not contain any particulate greater than 5 microns in size. Therefore, the hoist must have a 5 micron filter in its air supply. The filter must be upstream of the lubricator.

3.8.2 The filter servicing the trolley hoist can also service other hoists and air consuming equipment. In this case, the air filter must be in sized for the total air consumption of the equipment it is servicing.

3.9 **Air Dryer – ⚠ CAUTION** To prevent corrosion and hoist malfunction, employ an air dryer in the air supply system to ensure that dry air is supplied to the trolley hoist. If there is moisture in the air supplied to the trolley hoist, this moisture will cause corrosion on internal hoist and trolley components during periods when the hoist and trolley are idle leading to hoist and trolley malfunction.

3.10 Piping, Hoses and Fittings

3.10.1 **⚠ CAUTION** System Configuration – The system should be configured as shown in Figure 3-11. Since moisture tends to accumulate in compressed air systems, corrosion may result if the system is not periodically drained.

- Arrange for a drain in the air supply piping at the lowest point in the piping, and
- Periodically drain the system to remove moisture/water from the system and to prevent corrosion.
- Filter, regulator (if equipped), and lubricator must be arranged in the order shown in Figure 3-12.

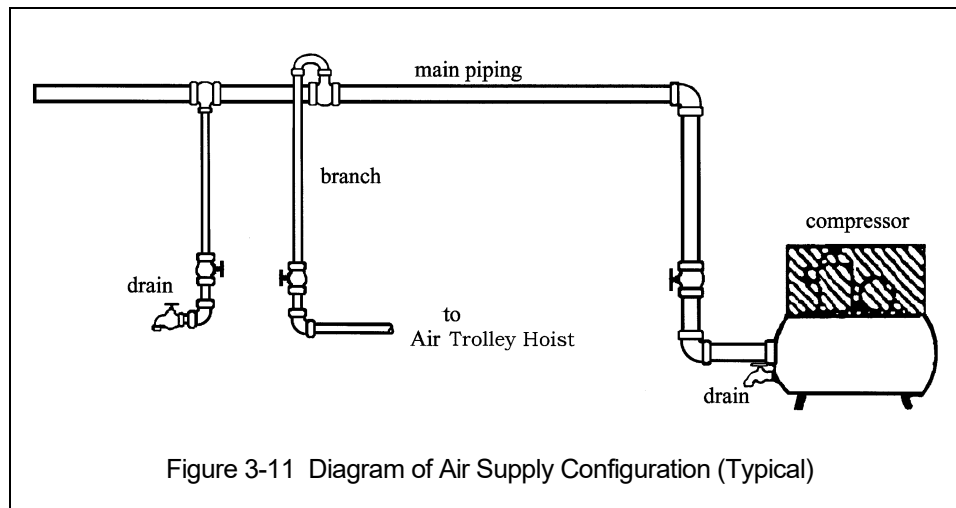

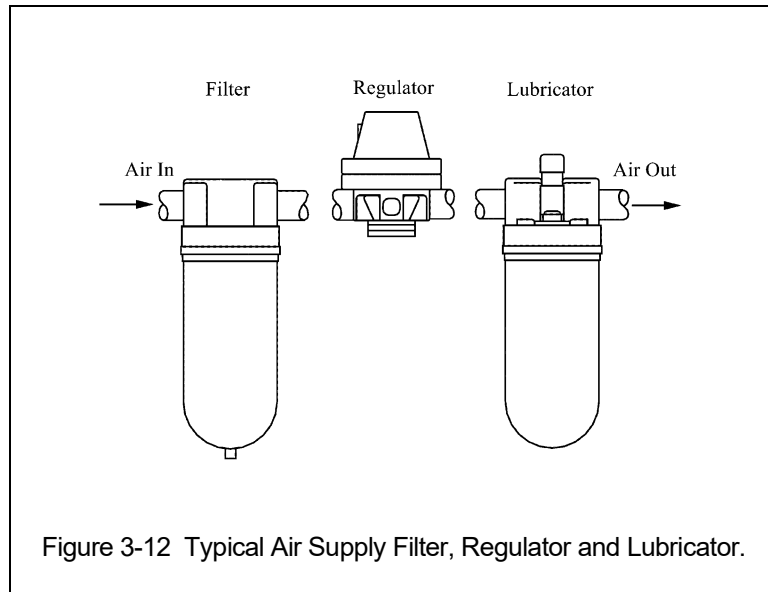

3.10.2 **NOTICE** Piping – Pipe should be sized to accommodate the trolley hoist airflow requirements. Table 3-3 gives recommended pipe sizes.

Table 3-3 Air Supply Pipe and Hose Sizes		
Model	Diameter of Supply Pipe	Diameter of Supply Hose
TCRM250P, 500P, 1000P, 1000P2, 2000P2	Inside diameter 0.75 inch or larger	Inside diameter 0.5 inch or larger
TCRM3000P, 6000P2	Inside diameter 1.0 inch or larger	Inside diameter 0.75 inch or larger
TCKM3000P, 6000P2		

3.10.3 **NOTICE** Hoses – The connection from the air supply system piping to the trolley hoist must be made with a flexible pressure hose. Due to normal line losses in air supply lines:

- Do not use hose smaller than specified in Table 3-3, and
- Limit the length of the hose to that specified in Figure 3-13.

If your application exceeds these requirements consult factory.

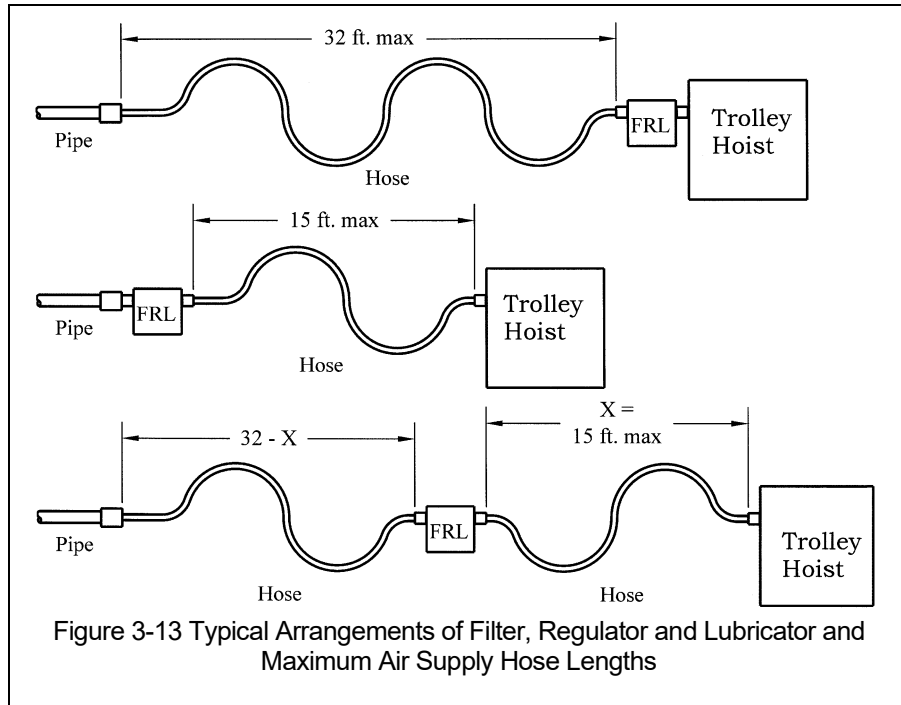

- 3.10.4 **⚠ CAUTION** Fittings – Important considerations regarding fittings in the hoist and trolley's air supply include:
- When connecting air supply components, remove all dirt or debris from the connecting surfaces of the hoses, pipes, fittings, or threaded fasteners to prevent contaminants from entering the hoist and trolley.
 - Keep airflow restrictions such as quick disconnect fittings, bends, elbows, and adapters to a minimum.
- 3.10.5 **⚠ CAUTION** Before connecting the trolley hoist to its air supply line, perform the proper draining and purging procedures to prevent contaminants or moisture from entering the hoist.

3.11 Connecting Trolley Hoist to Air Supply

- 3.11.1 **⚠ WARNING** **HAZARDOUS AIR PRESSURE IS PRESENT IN THE HOIST AND TROLLEY, IN THE SUPPLY OF COMPRESSED AIR TO THE TROLLEY HOIST, AND IN THE CONNECTIONS BETWEEN COMPONENTS.**
- 3.11.2 Shut off the air supply and stop the airflow completely. Lock out and tag out in accordance with ANSI Z244.1 "Personnel Protection -Lockout/Tagout of Energy Sources".
- 3.11.3 **⚠ CAUTION** Before connecting the air supply hose to the trolley , always purge the air hose to clear any debris and water.
- 3.11.4 Apply approximately 1 – 1½ ounce of turbine oil (see approved lubricant under Section 6.0 Lubricants) into the hose before attaching to the hoist.
- 3.11.5 Make connections to air supply; reference Figure 3-14.

- 3.11.6 **NOTICE** Where conditions dictate, the installation sequence can be reversed by connecting the air supply first, followed by mounting the trolley hoist.

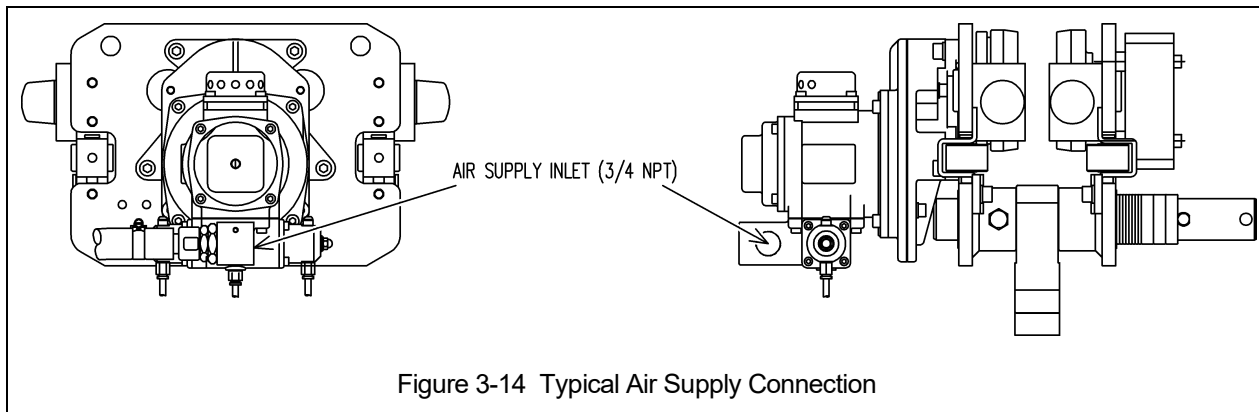

3.12 Pre-operational Checks and Trial Operation

- 3.12.1 Refer to the trolley's Nameplate and record the Code and Serial Number in the space provided on the cover of this manual.
- 3.12.2 Refer to the hoist's owner's manual and perform all pre-operational checks for the hoist.
- 3.12.3 Perform pre-operational checks for the trolley:

- **⚠ WARNING** Confirm the adequacy of the rated capacity for all slings, chains, wire ropes and all other lifting attachments before use. Inspect all load suspension members for damage prior to use and replace or repair all damaged parts.
- Ensure that trolley is properly installed on the beam, and stops for the trolley are correctly positioned and securely installed on the beam.
- Ensure that all nuts, bolts and split pins (cotter pins) are sufficiently fastened.
- Pull down on the Pendant and ensure that the Strain Relief Cable takes the force, not the Pendant Assembly.
- **⚠ CAUTION** Check air supply before everyday use. If the air supply volume and pressure is not sufficient the hoist and trolley may not function normally.

- 3.12.4 Confirm proper operation.

- Before operating read and become familiar with Section 4 - Operation.
- Before operating ensure that the hoist (and trolley) meets the Inspection, Testing and Maintenance requirements of ANSI/ASME B30.16.
- Before operating ensure that nothing will interfere with the full range of the hoist's (and trolley's) operation.

3.12.5 Proceed with trial operation to confirm proper operation.

- Verify that the controls agree with hoist direction. Make sure that depressing the Up button lifts the load chain and depressing the Down button lowers the load chain hook. If the load chain does not move in the correct direction when the push buttons are pushed, the air tubes are connected incorrectly. In this case, turn off the air supply and correct the pendant tube attachment at the hoist. The hook will then move in accordance with the directions of the push button.
- Operate the trolley through its full range of motion. Make sure the trolley runs smoothly and does not bind.
- Perform inspections per Section 5.3, "Frequent Inspections".

4.0 Operation

4.1 Introduction



DANGER

DO **NOT** WALK UNDER A SUSPENDED LOAD



WARNING

HOIST OPERATORS SHALL BE REQUIRED TO READ THE OPERATION SECTION OF THIS MANUAL, THE WARNINGS CONTAINED IN THIS MANUAL, INSTRUCTION AND WARNING LABELS ON THE HOIST OR LIFTING SYSTEM, AND THE OPERATION SECTIONS OF ANSI/ASME B30.16 and ANSI/ASME B30.10. THE OPERATOR SHALL ALSO BE REQUIRED TO BE FAMILIAR WITH THE HOIST AND HOIST CONTROLS BEFORE BEING AUTHORIZED TO OPERATE THE HOIST OR LIFTING SYSTEM.

HOIST OPERATORS SHOULD BE TRAINED IN PROPER RIGGING PROCEDURES FOR THE ATTACHMENT OF LOADS TO THE HOIST HOOK.

HOIST OPERATORS SHOULD BE TRAINED TO BE AWARE OF POTENTIAL MALFUNCTIONS OF THE EQUIPMENT THAT REQUIRE ADJUSTMENT OR REPAIR, AND TO BE INSTRUCTED TO STOP OPERATION IF SUCH MALFUNCTIONS OCCUR, AND TO IMMEDIATELY ADVISE THEIR SUPERVISOR SO CORRECTIVE ACTION CAN BE TAKEN.

HOIST OPERATORS SHOULD HAVE NORMAL DEPTH PERCEPTION, FIELD OF VISION, REACTION TIME, MANUAL DEXTERITY, AND COORDINATION.

HOIST OPERATORS SHOULD **NOT** HAVE A HISTORY OF OR BE PRONE TO SEIZURES, LOSS OF PHYSICAL CONTROL, PHYSICAL DEFECTS, OR EMOTIONAL INSTABILITY THAT COULD RESULT IN ACTIONS OF THE OPERATOR BEING A HAZARD TO THE OPERATOR OR TO OTHERS.

HOIST OPERATORS SHOULD **NOT** OPERATE A HOIST OR LIFTING SYSTEM WHEN UNDER THE INFLUENCE OF ALCOHOL, DRUGS, OR MEDICATION.

OVERHEAD HOISTS ARE INTENDED ONLY FOR VERTICAL LIFTING SERVICE OF FREELY SUSPENDED UNGUIDED LOADS. DO **NOT** USE HOIST FOR LOADS THAT ARE NOT LIFTED VERTICALLY, LOADS THAT ARE NOT FREELY SUSPENDED, OR LOADS THAT ARE GUIDED.

NOTICE

- Read ANSI/ASME B30.16 and ANSI/ASME B30.10.
- Read the hoist manufacturer's Operating and Maintenance Instructions.
- Read all labels attached to equipment.

The operation of an overhead hoist involves more than activating the hoist's controls. Per the ANSI/ASME B30 standards, the use of an overhead hoist is subject to certain hazards that cannot be mitigated by engineered features, but only by the exercise of intelligence, care, common sense, and experience in anticipating the effects and results of activating the hoist's controls. Use this guidance in conjunction with other warnings, cautions, and notices in this manual to govern the operation and use of your overhead hoist.

4.2 Shall's and Shall Not's for Operation

WARNING

Improper operation of a hoist can create a potentially hazardous situation which, if not avoided, could result in death or serious injury, and substantial property damage. To avoid such a potentially hazardous situation **THE OPERATOR SHALL:**

- **NOT** lift more than rated load for the hoist.
- **NOT** operate unless load is centered under hoist.
- **NOT** use damaged hoist or hoist that is not working properly.
- **NOT** use hoist with twisted, kinked, damaged, or worn chain.
- **NOT** use hoist if the bottom hook is capsized (see Hoist Manual).
- **NOT** use the hoist to lift, support, or transport people.
- **NOT** lift loads over people.
- **NOT** apply load unless load chain is properly seated in the load sheave (and idle sheave for hoist with two chain falls).
- **NOT** use the hoist in such a way that could result in shock or impact loads being applied to the hoist.
- **NOT** attempt to lengthen the load chain or repair damaged load chain.
- **NOT** operate hoist when it is restricted from forming a straight line from hook to hook in the direction of loading.
- **NOT** use load chain as a sling or wrap load chain around load.
- **NOT** apply the load to the tip of the hook or to the hook latch.
- **NOT** apply load if binding prevents equal loading on all load-supporting chains.
- **NOT** operate beyond the limits of the load chain travel.
- **NOT** operate hoist with missing/damaged chain springs, cushion rubbers, stoppers or striker plates.
- **NOT** leave load supported by the hoist unattended unless specific precautions have been taken.
- **NOT** allow the chain, or hook to be used as an electrical or welding ground.
- **NOT** allow the chain, or hook to be touched by a live welding electrode.
- **NOT** remove or obscure the warnings on the hoist.
- **NOT** operate a hoist on which the safety placards or decals are missing or illegible.
- Be familiar with operating controls, procedures, and warnings.
- Make sure the unit is securely attached to a suitable support before applying load.
- Make sure load slings or other approved single attachments are properly sized, rigged, and seated in the hook saddle.
- Take up slack carefully - make sure load is balanced and load-holding action is secure before continuing.
- Make sure all persons stay clear of the supported load.
- Protect the hoist's load chain from weld splatter or other damaging contaminants.
- Report Malfunctions or unusual performances (including unusual noises) of the hoist and remove the hoist from service until the malfunction or unusual performance is resolved.
- Make sure hoist limit switches function properly.
- Warn personnel before lifting or moving a load.
- Warn personnel of an approaching load.

⚠ CAUTION

Improper operation of a hoist can create a potentially hazardous situation which, if not avoided, could result in minor or moderate injury, or property damage. To avoid such a potentially hazardous situation **THE OPERATOR SHALL:**

- Maintain a firm footing or be otherwise secured when operating the hoist.
- Check brake function by tensioning the hoist prior to each lift operation.
- Use hook latches. Latches are to retain slings, chains, etc. under slack conditions only.
- Make sure the hook latches are closed and not supporting any parts of the load.
- Make sure the load is free to move and will clear all obstructions.
- Avoid swinging the load or hook.
- Make sure hook travel is in the same direction as shown on controls.
- Inspect the hoist regularly, replace damaged or worn parts, and keep appropriate records of maintenance.
- Use the hoist manufacturer's recommended parts when repairing the unit.
- Lubricate load chain per hoist manufacturer's recommendations.
- **NOT** use the hoist load limiting or warning device to measure load.
- **NOT** use limit switches as routine operating stops. They are emergency devices only.
- **NOT** allow your attention to be diverted from operating the hoist.
- **NOT** allow the hoist to be subjected to sharp contact with other hoists, structures, or objects through misuse.
- **NOT** adjust or repair the hoist unless qualified to perform such adjustments or repairs.

4.3 Trolley and Hoist Controls

4.3.1 Pendant Control - When using the pendant control depress the Up lever or button to raise the hoist's hook or the Down lever or button to lower the hoist's hook as shown in Figure 4-1. Depress the Left and Right levers or buttons to move the trolley horizontally. To stop motion release the levers or buttons.

4.3.2 **⚠ CAUTION** Make sure the air motor completely stops before reversing direction.

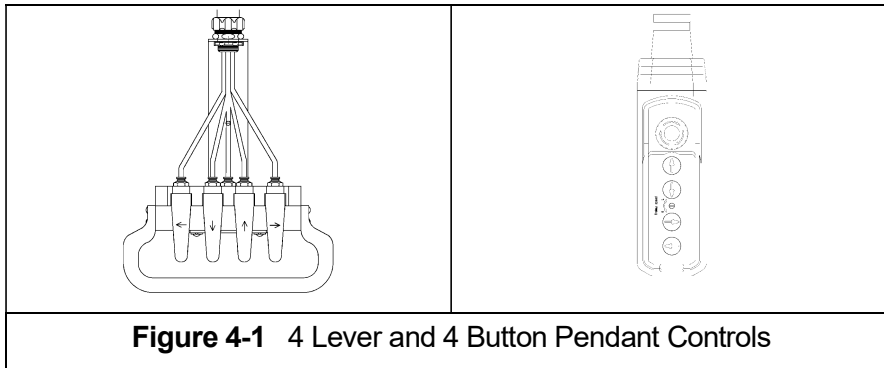

5.0 Inspection

5.1 General

- 5.1.1 The inspection procedure herein is based on ANSI/ASME B30.16. The following definitions are from ANSI/ASME B30.16 and pertain to the inspection procedure below.
- **Personnel Competence** – Persons performing the functions identified in this volume shall meet the applicable qualifying criteria stated in this volume and shall through education, training, experience, skill, and physical fitness, as necessary, be competent and capable to perform the functions as determined by the employer or employer's representative.
 - **Qualified Person** – a person who, by possession of a recognized degree or certificate of professional standing, or who, by extensive knowledge, training, and experience, has successfully demonstrated the ability to solve or resolve problems relating to the subject matter and work.
 - **Normal Service** – that distributed service which involves operation with randomly distributed loads within the rated load limit, or uniform loads less than 65% of rated load for not more than 25% of the time.
 - **Heavy Service** – that service which involves operation within the rated load limit which exceeds normal service.
 - **Severe Service** – that service which involves normal or heavy service with abnormal operating conditions.

5.2 Inspection Classification

- 5.2.1 Inspection Classification – the inspection procedure for trolleys in regular service is divided into two general classifications based upon the intervals at which inspection should be performed. The intervals in turn are dependent upon the nature of the critical components of the trolley and the degree of their exposure to wear, deterioration, or malfunction. The two general classifications are herein designated as FREQUENT and PERIODIC, with respective intervals between inspections as defined below.
- 5.2.2 Initial Inspection – prior to initial use, all new, re-installed, altered, or modified trolleys shall be inspected by a designated person to ensure compliance with the applicable provisions of this manual.
- 5.2.3 PREOPERATIONAL Inspection – Visual inspection performed before the first use of each shift with records not required.
- 5.2.4 FREQUENT Inspection – visual examinations by the operator or other designated personnel with intervals per the following criteria:
- Normal service – monthly
 - Heavy service – weekly to monthly
 - Severe service – daily to weekly
 - Special or infrequent service – as recommended by a qualified person before and after each occurrence.
- 5.2.5 PERIODIC Inspection – visual inspection by a designated person with intervals per the following criteria:
- Normal service – yearly
 - Heavy service – semiannually
 - Severe service – quarterly
 - Special or infrequent service - as recommended by a qualified person before the first such occurrence and as directed by the qualified person for any subsequent occurrences.

5.3 Frequent Inspection

5.3.1 Inspections should be made on a FREQUENT basis in accordance with Table 5-1, "Frequent Inspection." Included in these FREQUENT Inspections are observations made during operation for any defects or damage that might appear between Periodic Inspections. Evaluation and resolution of the results of FREQUENT Inspections shall be made by a designated person such that the trolley is maintained in safe working condition.

Table 5-1 Frequent Inspection
All functional operating mechanisms for proper operation, proper adjustment, and unusual sounds.
Trolley braking system for proper operation
Hoist(s) in accordance with ANSI/ASME B30.16
Upper Limit Devices in accordance with ANSI/ASME B30.16
Hook(s) and hook latches in accordance with ANSI/ASME B30.10

5.4 Periodic Inspection

5.4.1 Inspections should be made on a PERIODIC basis in accordance with Table 5-2, "Periodic Inspection." Evaluation and resolution of the results of PERIODIC Inspections shall be made by a designated person such that the trolley is maintained in safe working condition.

5.4.2 For inspections where load suspension parts of the trolley are disassembled, a load test per ANSI/ASME B30.16 must be performed on the trolley after it is re-assembled and prior to its return to service.

Table 5-2 Periodic Inspection
Requirements of frequent inspection.
Loose or missing bolts, nuts, pins or rivets.
Worn, cracked, or distorted parts such as pins, bearings, wheels, shafts, gears, rollers, yokes, and bumpers.
Excessive wear of brake system parts
Deterioration of air components such as pendant and hose connections.
Proper function of motion limit devices that interrupt trolley hoist movement or cause a warning to be activated.
Function, instruction and warning labels for legibility and placement.

5.5 Occasionally Used Trolleys

5.5.1 Trolleys that are used infrequently shall be inspected as follows prior to placing in service:

- Trolley Idle More Than 1 Month, Less Than 1 Year: Inspect per FREQUENT Inspection criteria in Section 5.3.
- Trolley Idle More Than 1 Year: Inspect per PERIODIC Inspection criteria in Section 5.4.

5.6 Inspection Records

- 5.6.1 Dated inspection reports and records should be maintained at time intervals corresponding to those that apply for the hoist's PERIODIC interval per Section 5.2.5. These records should be stored where they are available to personnel involved with the inspection, maintenance, or operation of the trolley.

5.7 Inspection Methods and Criteria

- 5.7.1 This section covers the inspection of specific items. The list of items in this section is based on those listed in ANSI/ASME B30.16 for Frequent and Periodic Inspection. In accordance with ANSI/ASME B30.16, these inspections are not intended to involve disassembly of the trolley. Rather, disassembly for further inspection would be required if frequent or periodic inspection results so indicate. Such disassembly and further inspection should only be performed by a qualified person trained in the disassembly and re-assembly of the trolley.

Item	Method	Criteria	Action
Functional operating mechanisms.	Visual, Auditory	Mechanisms should be properly adjusted and should not produce unusual sounds when operated.	Repair or replace as required.
Braking System Operation	Function	Trolley must come to a smooth stop within 10% of its traveling speed when the pendant button is released.	Repair or replace as required.
Housing and Mechanical Components	Visual, Auditory, Vibration, Function	Trolley components including, suspension shafts, track wheels, track wheel axles, clevises, connection yokes, suspension bolts, shafts, gears, bearings, pins, rollers, and bumpers should be free of cracks, distortion, significant wear and corrosion. Evidence of same can be detected visually or via detection of unusual sounds or vibration during operation.	Replace.
Side Plates	Visual	Must be free of significant deformation	Replace.
Bolts, Nuts, Snap Rings, and Split Pins	Visual, Check with Proper Tool	Bolts, nuts, snap rings and split pins should not be loose.	Tighten or replace as required.
Track Wheel - Tread	Visual, Measure	Diameter of the inside and outside tread surface should not be less than the discard value shown in Table 5-4.	Replace.
Track Wheel - Gear	Visual	Teeth should not be cracked, damaged, or excessively worn.	Replace.
Side Rollers - Wear	Visual, Measure	Diameter should not be less than the discard value shown in Table 5-5.	Replace.
Suspension Shaft	Visual, Measure	Suspension shaft should not be bent. Diameter should not be worn by 10% or more.	Replace.
Motor Brake	Visual, Measure	Brake dimension "A" should not exceed the discard value listed in Table 5-6. Refer to Section 6.3 for gaining access to motor brake and inspection procedures. Braking surfaces should be clean and smooth.	Replace.

Table 5-3 Trolley Inspection Methods and Criteria

Item	Method	Criteria	Action
Pendant – Tubing	Visual	Surface of tubing should be free from nicks, gouges, and abrasions. Tubing should not leak even when flexed back-and-forth. Tubing should not be deformed or loosely connected and free of significant deterioration.	Replace
Pendant – Levers or Buttons	Function	Depressing and releasing levers or buttons should start or stop load chain or trolley movement.	Repair or replace as necessary.
Pendant – Assembly	Visual	Pendant Assembly – housing, bracket and conduit should be free of damage. Pendant Strain Relief Cable should absorb all the load associated with forces applied to the pendant.	Replace.
Air Supply Hoses	Visual, Air Flow	Surface of hose should be free from nicks, gouges, and abrasions. Hose should not leak even when flexed back-and-forth. Hose should not be deformed or loosely connected and free of significant deterioration.	Replace.
Air Hose Fittings	Visual	All Fittings should not be cracked or damaged.	Repair or replace as necessary.
Pendant - Labels	Visual	Labels denoting functions should be legible.	Replace.
Warning Labels	Visual	Warning Labels should be affixed to the pendant cord (see Section 1.2) and they should be legible.	Replace.
Trolley Capacity Label	Visual	The label that indicates the capacity of the trolley should be legible and securely attached to the trolley.	Replace.

Table 5-4 Track Wheel Wear Dimensions

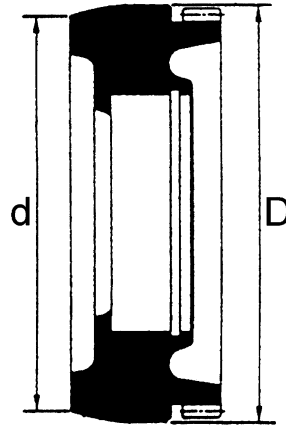

Note: Track wheels are for flat and tapered flanges.

Trolley Code	"d" Dimension inch (mm)		"D" Dimension inch (mm)	
	Standard	Discard	Standard	Discard
MCR1000	3.60 (91.5)	3.44 (87.5)	3.74 (95)	3.58 (91)
MCR3000	4.76 (121)	4.49 (114)	4.92 (125)	4.65 (118)
MCR6000	6.34 (166)	6.14 (156)	6.89 (175)	6.50 (165)

Table 5-5 Side Roller Wear Dimensions

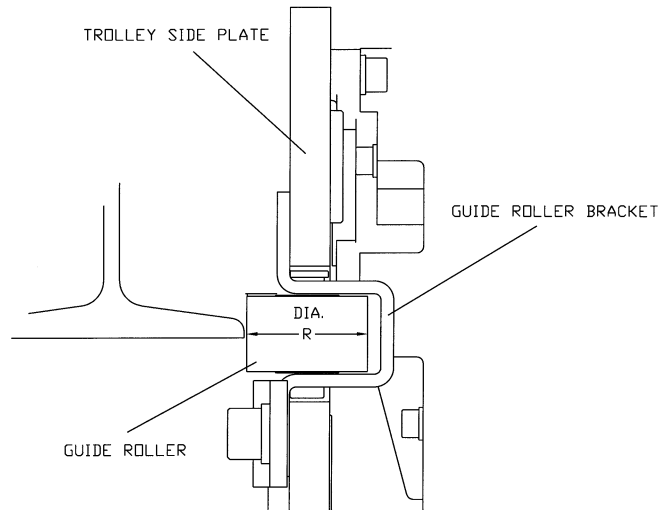

Trolley Code	"R" Dimension inch (mm)	
	Standard	Discard
MCR1000	1.50 (38)	1.46 (37)
MCR3000	1.69 (43)	1.65 (42)
MCR6000	2.24 (57)	2.20 (56)

Table 5-6 Motor Brake Wear Dimensions

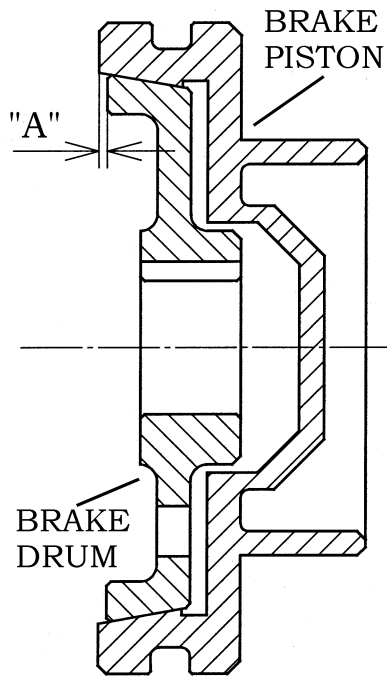

Trolley Code	"A" Dimension - inch (mm)	
	Standard	Discard
MCR1000	0 (0)	0.04(1.0)
MCR3000		
MCR6000		

6.0 Maintenance & Handling

6.1 Air Trolley Motor Lubrication

6.1.1 See Section 3.7 for lubrication requirements.

6.1.2 **▲ CAUTION** Lubrication to the motor will be provided primarily by the air supply lubricator. The recommended amount is 10-15 drops/minute (0.2-0.3cc/min.). Refer to Table 6-1 below for the approved lubricant for use with your air hoist.

6.1.3 Additional lubrication to the reduction gears is not necessary. When disassembling the hoist for service or repair, apply new grease to the gears before reassembling the hoist.

Lubrication	Grade	Application	Part Location
Turbine Oil	ISO VG 32-56 or equivalent	Air motor	Lubricator

6.2 Air Trolley Lubrication

6.1.1 Lubricate the following trolley components with NLGI (National Lubricating Grease Institute) #2 or equivalent grease.

6.1.2 Track Wheel Gear – Clean and re-grease the Track Wheel gears and motor output pinion every three months (more frequently for heavier usage or severe conditions). Do not use an excessive amount of grease and avoid getting any grease on the running surfaces of the Track Wheels or the beam.

6.1.3 Gear Box – The reduction gearing in the motor should be cleaned and lubricated at least once per year for normal usage. Clean and lubricate the reduction gear assembly more frequently for heavier usage or severe conditions. Gain access to the gears by removing the four bolts that mount the motor assembly to the trolley Side Plate. Make sure to properly orient and reuse the neoprene gasket between the motor and Side Plate.

6.1.4 Suspension Pins, Bolts and Shafts – Grease at least twice per year for normal usage (more frequently for heavier usage or severe conditions).

6.3 Brake

6.1.5 The trolley motor brake is NOT adjustable.

6.1.6 Motor Brake Removal – Evenly remove the four Bolts that attach the Brake Cover to the Case to release the brake spring. Carefully remove the Cover and brake components.

6.1.7 Brake Inspection – The brake is designed for a long life and should provide years of trouble-free service. If the brake is being inspected due to excessive trolley drift during operation (see Section 5.7), disassemble the motor brake and inspect all motor brake parts. Braking surfaces should be clean and smooth. Replace the Brake Drum and/or Brake Piston if necessary. For normal inspections, the Brake Drum and Brake Piston wear should be measured as follows.

- 1) Refer to Table 5-6.
- 2) Measure the distance "A" using calipers. Make sure the Brake Piston is square against the Brake Drum.
- 3) Compare the measurement with the values listed in Table 5-6. Replace the Brake Drum and/or Brake Piston if the "A" measurement exceeds the discard limit.

- 6.1.8 Brake O-ring Inspection – The brake piston and brake cover o-rings should be free of nicks, cuts and breaks.
- 6.1.9 Motor Brake Installation - After the brake is inspected, carefully place the brake components into the Case. Be sure to reseal the Brake Cover to the Case surface using a small bead of liquid (hi-temperature) sealant. Install the Brake Cover attachment bolts.

6.4 Storage

- 6.4.1 The storage location should be clean and dry.
- 6.4.2 Care should be take to not damage any of the air fittings.
- 6.4.3 When storing the trolley for long periods of time, apply approximately ½ ounce of lubrication into the air hose and operate the trolley for 3 – 4 seconds.

6.5 Outdoor Installation

- 6.5.1 For trolley and hoist installations that are outdoors, the trolley and hoist **MUST** be covered and protected from the weather when not in use.
- 6.5.2 Possibility of corrosion on components of the trolley increases for installations where salt air and high humidity are present. In order to prevent internal corrosion from occurring, the hoist must be operated using proper quality air at least once per week by moving the trolley a distance in each direction. For such situations you may need to operate your trolley more often than once per week.
- 6.5.3 The trolley may require more frequent lubrication...
- 6.5.4 Make frequent and regular inspections of the unit's condition and operation.

7.0 Troubleshooting

⚠ WARNING

HAZARDOUS AIR PRESSURE IS PRESENT IN THE HOIST, IN THE SUPPLY OF COMPRESSED AIR TO THE HOIST, AND IN THE CONNECTIONS BETWEEN COMPONENTS.

Before performing ANY maintenance on the equipment, de-energize the supply of compressed air to the equipment, and lock and tag the supply device in the de-energized position. Refer to ANSI Z244.1, "Personnel Protection - Lockout/Tagout of Energy Sources."

Only trained and competent personnel should inspect and repair this equipment.

Table 7-1 Troubleshooting Guide

Symptom	Cause	Remedy
Trolley will not operate	Loss of power	Check air tubes, hoses and air supply.
	Wrong air volume or pressure	Check air volume and pressure against the rating on the nameplate of the trolley.
	Improper, loose, or broken tubing or hoses in trolley air supply system	Shut off air supply, check tubing and hose connections at the hoist, trolley and push-button pendant.
Trolley drifts excessively when stopping	Motor brake not holding	Clean and inspect brake. Replace if necessary. (see Section 6.3 for Brake Inspection)
Trolley Operates Intermittently	See Trolley will not operate	
Traveling speed is slow	Low air pressure at hoist inlet port.	Repair or adjust air supply or filters. Check for airline obstruction.
	Air supply hose or piping is too small.	Replace hose or piping sizes with recommended sizes in Section 3.10 .
	Malfunction of brake.	Repair at service facility.
	Bending or crimping of pendant hoses or control tubes	Correct or repair the bend or crimp in hose and/or control tubes
	Lack of sufficient oil in air supply to trolley	Increase oil in air supply to trolley in accordance with requirements in Section 6.1.
	Exhaust Silencer clogged	Clean or replace.
	Air flow capacity of compressed air system insufficient	Increase airflow capacity of compressed air system to requirements in Section 2.0.
	Air motor vanes or bearings worn	Repair at service facility.
	Air supply to hoist contains dirt or debris	Filter the air supply to the trolley in accordance with the requirements in Section 3.8.

8.0 Warranty

All products sold by Harrington Hoists, Inc. are warranted to be free from defects in material and workmanship from date of shipment by Harrington for the following periods:

- 1 year – Electric and Air Powered Hoists (excluding (N)ER2 Enhanced Features Models and EQ/SEQ Models), Powered Trolleys, Powered Tiger Track Jibs and Gantries, Crane Components, Below the Hook Devices, Spare / Replacement Parts**
- 2 years – Manual Hoists & Trolleys, Beam Clamps**
- 3 years – (N)ER2 Enhanced Features Model Hoists and EQ/SEQ Model Hoists**
- 5 years – Manual Tiger Track Jibs and Gantries, TNER Pull - Rotor Motor Brake, and EQ/SEQ Pull-Rotor Motor Brake**
- 10 years – (N)ER2 “The Guardian” Smart Brake**

The product must be used in accordance with manufacturer’s recommendations and must not have been subject to abuse, lack of maintenance, misuse, negligence, or unauthorized repairs or alterations.

Should any defect in material or workmanship occur during the above time period in any product, as determined by Harrington Hoist’s inspection of the product, Harrington Hoists, Inc. agrees, at its discretion, either to replace (not including installation) or repair the part or product free of charge and deliver said item F.O.B. Harrington Hoists, Inc. place of business to customer.

Customer must obtain a Return Goods Authorization as directed by Harrington or Harrington’s published repair center prior to shipping product for warranty evaluation. An explanation of the complaint must accompany the product. Product must be returned freight prepaid. Upon repair, the product will be covered for the remainder of the original warranty period. Replacement parts installed after the original warranty period will only be eligible for replacement (not including installation) for a period of one year from the installation date. If it is determined there is no defect, or that the defect resulted from causes not within the scope of Harrington’s warranty, the customer will be responsible for the costs of returning the product.

Harrington Hoists, Inc. disclaims any and all other warranties of any kind expressed or implied as to the product’s merchantability or fitness for a particular application. Harrington will not be liable for death, injuries to persons or property or for incidental, contingent, special or consequential damages, loss or expense arising in connection with the use or inability whatever, regardless of whether damage, loss or expense results from any act or failure to act by Harrington, whether negligent or willful, or from any other reason.

9.0 Parts List

When ordering Parts, please provide the trolley's code number and serial number located on the trolley's nameplate (see figure 9-1 below).

Reminder: Per sections 1.1 and 3.12.1 to aid in ordering Parts and Product Support, record the Trolley's code number and serial number in the space provided on the cover of this manual.

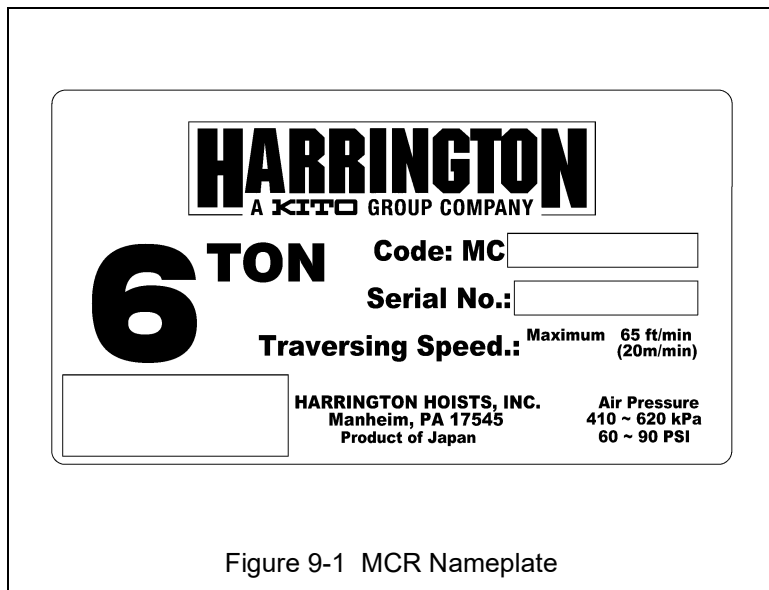

Figure 9-1 MCR Nameplate

The parts list is arranged into the following sections:

Section	Page
9.1 Side Plates, Gearbox and Suspension Parts.....	42
9.2 Air Motor and Control Valve Parts.....	46
9.3 Air Connection and Pendant Parts.....	48

9.1 Side Plates, Gearbox and Suspension Parts

Fig. No.	Description	Qty.	MCR1000	MCR3000	MCR6000
1	Track Wheel "G" Assembly	2	MCR422610010	MCR422630010	MCR422660010
2	Track Wheel "S" Assembly	2	MCR422610020	MCR422630020	MCR422660020
3	Bearing	4	9000702 (6302ZZ)	9000705 (6305ZZ)	9000708 (6308ZZ)
4	Retaining Ring	4	9047242 (H-42)	9047262 (H-62)	9047290 (H-90)
5	Side Plate "G" Assembly	1	MCR42261003B	MCR42263003B	MCR42266003B
6	Side Plate "S" Assembly	1	MCR42261006B	MCR42263006B	MCR42266006B
7	Retaining Ring	4	9047115 (S-15)	9047125 (S-25)	9047140 (S-40)
9	Wheel Washer	4	MCR422610090	MCR422630090	MCR422660090
10	Side Roller	4	MCR422610100	MCR422630100	MCR422660100
11	Side Roller Shaft	4	MCR422610110	MCR422630110	MCR422660110
12	Side Roller Holder	4	MCR422610120	MCR422630120	MCR422660120
13	Stopper Plate	4	MCR422610130	MCR422630130	MCR422660130
14	Socket Bolt	4	9091272 (M8X20)	9091294 (M10X25)	90913150 (M16X35)
15	Spring Washer	4	9012711 (MX8)	9012712 (MX10)	9012715 (MX16)
16	Suspension Shaft	1	MCR422610700	MCR422630700	MCR422660700
17	Bolt	1	MCR422610170	MCR422630170	MCR422660170
18	Slotted Nut	1	T3P154020 (M10)	T3P154050 (M12)	T3G154075 (M16)
19	Split Pin	1	9009414-5 (2.5X18)	9009423 (3.2X20)	9009436 (4X30)
20	Shaft Stopper Pin	1	MCR422610200	MCR422630200	MCR422660200
21	Split Pin	1	9009432 (4X20)		9009444 (5X30)
22	Thick Spacer	(x)	MCR422610210 (5)	MCR422630210 (3)	MCR422660210 (3)
23	Thin Spacer	8 (x)	MCR422610710 (8)	MCR422630710 (8)	MCR422660710 (9)
24	Bumper	4	MR1DS9631	MR1FS9631	
25	Spring Washer	4	9012711 (M8)		
26	Nut	4	9093424 (M8X1.25)		
27	Bumper Bracket	4	MCR422612750	MCR422632750	MCR422662750
28	Square Spacer	8 4	9042744 MCR131411010	9042742 MCR131411030	9042745 MCR131411060
29	Socket Bolt	8	9091272 (M8X22)	9091295 (M10X30)	90913151 (M16X40)
30	Spring Washer	8	9012711 (M8)	9012712 (M10)	9012715 (M16)
31	Gear Case	1	MCR422610220		
32	Bearing	2	9000605 (6205ZZ)		
33	Retaining Ring	1	9047252 (H-52)		
34	Spring Pin	2	91481113 (8X12)		
35	Drive Gear	1	MCR422610230	MCR422630230	MCR422660230
36	Retaining Ring	1	9047125 (S-25)		
37	Gear	1	MCR422610240		
38	Gear Spacer	1	MCR422610250		
39	Socket Bolt	4	90912945 (M10X28)		
40	Spring Washer	4	9012712 (M10)		
41	Gear Case Packing	1	MCR136102099		
42	Gear Cover	1	MCR422610270		
43	Bearing	2	9000505 (6005ZZ)		
44	Socket Bolt	2	9091277 (M8X45)		
45	Socket Bolt	2	9091272 (M8X20)		
46	Spring Washer	4	9012711 (M8)		
47	Pinion	1	MCR422610280		
48	Retaining Ring	1	9047125 (S-25)		
49	Socket Bolt	4	9091272 (M8X20)		

9.1 Side Plates, Gearbox and Suspension Parts

Fig. No.	Description	Qty.	MCR1000	MCR3000	MCR6000
101	Capacity Name Plate ¼ Ton	1	6072503		
	Capacity Name Plate ½ Ton		6072501		
	Capacity Name Plate 1 Ton		MCR137301041		
	Capacity Name Plate 2 Ton			6072502	
	Capacity Name Plate 3 Ton			MCR137301043	
	Capacity Name Plate 6 Ton				MCR137301046
102	Socket Bolt	4	9091203 (M4X10)		
103	Name Plate	1	MCR137301049		
104	Rivet	4	MCR133001110		
113	Balance Weight	1	MCR422610950		
114	Balance Weight Washer	4	MCR422610970		
115	Socket Bolt	4	9091282 (M8X70)	9091283 (M8X75)	9091284 (M8X80)
116	Suspender TCR250, 500 & 1000	1	6040201		
	Suspender TCR1000-2		60403		
	Suspender TCR2000-2			6040401	
	Suspender TCR3000			MCR422630330	
	Suspender TCR6000				MCR422770350
	Suspender TCK3000				MCR422758350
	Suspender TCK6000				MCR42273350
117	Hanger TCR250, 500 & 1000	1	MCR422695550		
	Hanger TCR1000-2		MCR422710550		
	Hanger TCR2000-2			MCR422740550	
	Hanger TCR3000			MCR422755550	
	Hanger TCR6000				MCR422770550
	Hanger TCK3000				MCR422758550
	Hanger TCK6000				MCR422773550
118*	Socket Bolt TCR250, 500, 1000-2, 1000 & 2000-2	1	9091269 (M8X12)		
	Socket Bolt TCR3000 & 6000			9091271 (M8X16)	
	Socket Bolt TCK3000 & 6000			90912111 (M12X16)	
123	Hanger Bracket	1	MCR422610600	MCR422630610	MCR42266065B
124	Socket Bolt	3	9091273 (M8X25)	9091274 (M8X30)	
125	Nut	3	9093424 (M8)		
126	Spring Washer	3	9012711 (M8)		
127*	Socket Bolt TCR250, 500, 1000-2, 1000 & 2000-22	1	9091271 (M8X16)		
	Socket Bolt TCR3000 & 6000			9091272 (M8X20)	
128	Split Pin	1			9009423 (3.2X20)

*Use Socket Bolt figure no. 127 in place of no. 118 when optional chain container is installed on hoist.

This Page Intentionally Left Blank

9.2 Air Motor and Control Valve Parts

Fig. No.	Description	Qty.	MCR1000 MCR3000 MCR6000
51	Valve Body	1	MCR422601010
52	Valve Bushing ¹	1	MCR422601020
53	O-Ring	4	MCR131117026
54	Throttle Valve	1	MCR422601040
55	Piston ¹	2	MCR422601050
56	O-Ring	2	MCR131151025
57	Piston Shaft	1	MCR422601070
58	Socket Bolt	2	9091228 (M5X15)
59	Seal Washer	2	TCR136102094
60	Valve Cap	2	MCR422601100
61	O-Ring	2	MCR131103029
62	Throttle Valve Spring	2	MCR130802261
63	Spring Seat	2	MCR426223B50
64	Spring Seat Shaft	2	MCR426261B60
65	Washer	2	MCR136102095
66	Acorn Nut	2	9158703 (M6)
67	Element Holder ¹	2	MCR426221G50
68	Element	2	MCR136302010
69	Seal Washer	4	TCR136102094
70	Socket Bolt	8	9091227 (M5X14)
71	Valve Body Packing	1	MCR136102098
72	Socket Bolt	4	9091250 (MX20)
80	Case	1	MCR422601300
81	Rotor	1	MCR422601310
82	Retaining Ring	1	9047116 (S-16)
83	Brake Drum Key	1	MCR422601330
84	Vane	8	MCR137102014
85	Cylinder	1	MCR422601350
86	Front Plate	2	MCR426261K70
87	Bearing	2	9000603 (6203ZZ)
88	Knock Pin	1	MCR130402007
89	Brake Drum	1	MCR422601390
90	Brake Piston	1	MCR422601400
91	O-Ring	1	MCR131111371
92	Brake Spring	1	MCR130802101
93	Brake Cover	1	MCR422601430
94	O-Ring	1	MCR131103051
95	Hex Socket Pipe Plug	1	MCR134901001
96	Socket Bolt	4	9091250 (M6X20)
97	Exhaust Plate	1	MCR422601470
98	Silencer	1	MCR137402045
99	Exhaust Cover	1	MCR422601490
100	Socket Bolt	4	9091250 (M6X22)

¹Fig. No. 52, 55 and 67 are part of the Valve Renewal Kit, P/N MCR42260102D. Valve Renewal Kit provides “fine feathering” control. Early trolley versions had no speed control.

9.3 Air Connection and Pendant Parts

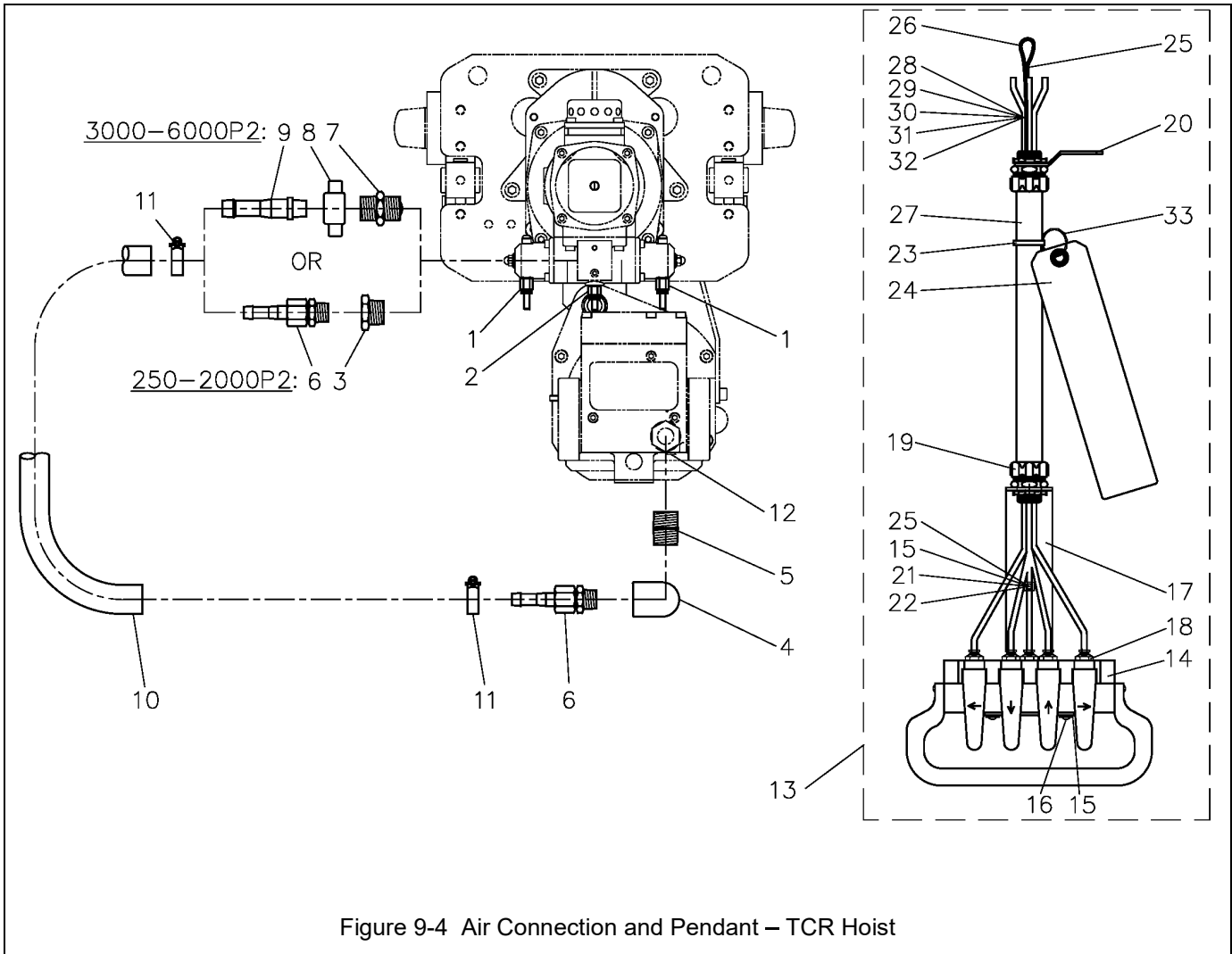

Figure 9-4 Air Connection and Pendant – TCR Hoist

9.3 Air Connection and Pendant Parts

Fig. No.	Description	Qty.	TCRM250P TCRM500P TCRM1000P2 TCRM1000P TCRM2000P2	TCRM3000 TCRM6000
1	Tube Fitting	2	MCR135106105	
2	Tube Fitting	1	MCR135106101	
3	Pipe Adapter	1	MCR134706040	
4	Elbow	1	MCR135102004	MCR135101004
5	Nipple	1		MCR135004004
6	Hose Stem Assembly	2	TCR1350005HH	
		1		TCR420845DHH
7	Nipple w/Screen	1		MCR41000136B
8	Hose Nut	1		MCR135600101
9	Hose Stem	1		MCR134800101
10	Hose	1	MCR137202009	MCR137202017
11	Hose Clamp	2	MCR137501021	MCR137501026
12	Hex Socket Pipe Plug	1	MCR134902001	
13	Pendant Assembly	1	60858	
14	Pendant Complete	1	60860	
15	Washer	3	9012709	
16	Socket Bolt	2	9738061	
17	Pendant Handle Bracket	1	60859	
18	Tube Fitting	5	MCR135106102	
19	Straight Fitting	2	9008105	
20	Under Cover	1	TCR426224472	
21	Socket Bolt	1	9091229	
22	Nut	1	9093417	
23	Cable Tie	1	9006603	
24	Warning Tag	1	WTAG7	
25	Cable Clamp	2	9012301	
26	Strain Relief Cable	FT	9013120	
27	Conduit	FT	9008303	
28	Tubing - Black	FT	9013114	
29	Tubing - Yellow	FT	9013138	
30	Tubing - Green	FT	9013139	
31	Tubing - Clear	FT	9013116	
32	Tubing - Red	FT	9013115	
33	Tag Holder	1	E3S787003	

9.3 Air Connection and Pendant Parts

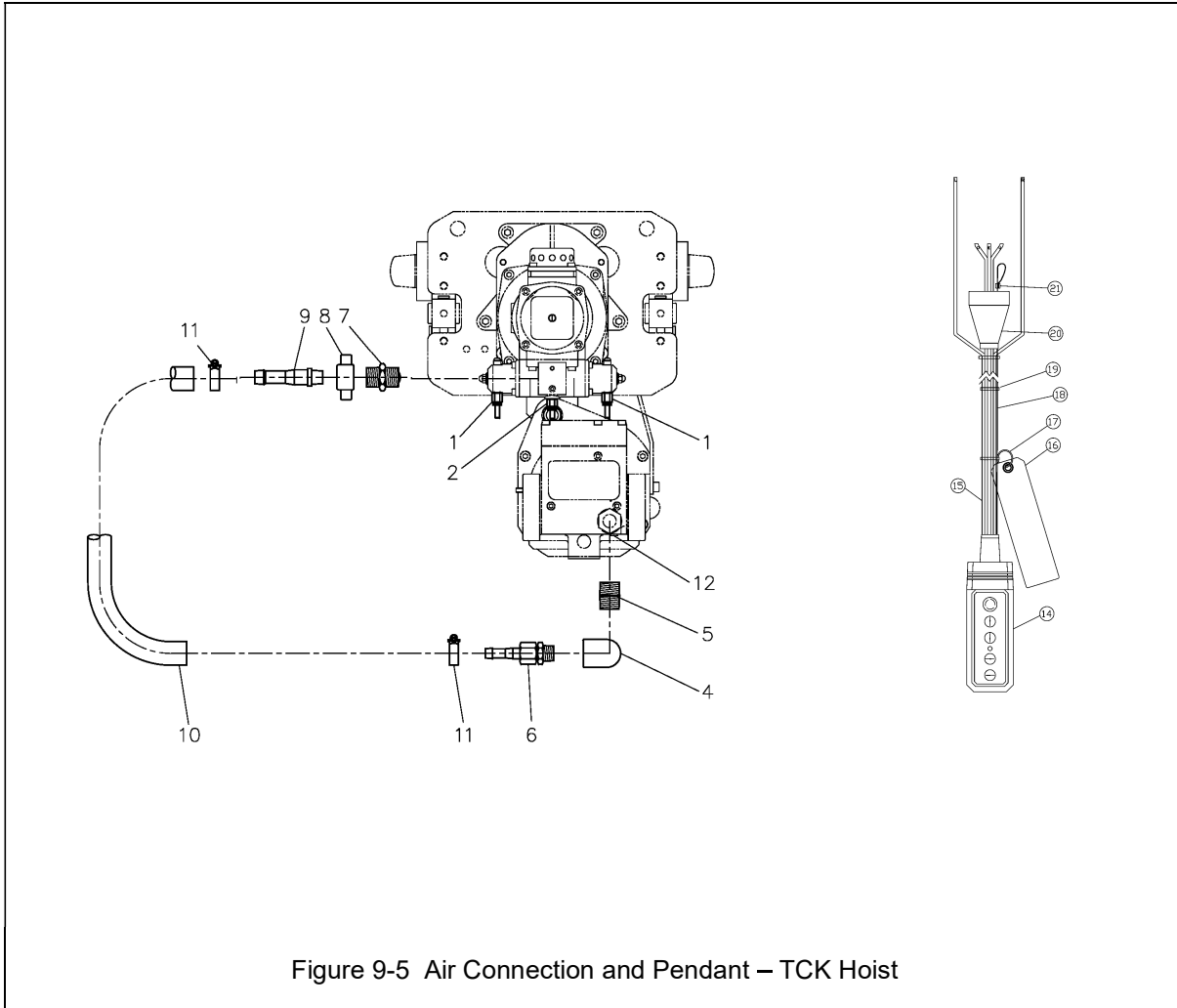

Figure 9-5 Air Connection and Pendant – TCK Hoist

9.3 Air Connection and Pendant Parts

Fig. No.	Description	Qty.	TCKM3000 TCKM6000
1	Tube Fitting	2	MCR135106105
2	Tube Fitting	1	MCR135106101
4	Elbow	1	MCR135101004
5	Nipple	1	MCR135004004
6	Hose Stem Assembly	1	TCR420845DHH
7	Nipple w/Screen	1	MCR41000136B
8	Hose Nut	1	MCR135600101
9	Hose Stem	1	MCR134800101
10	Hose	1	MCR137202017
11	Hose Clamp	2	MCR137501026
12	Hex Socket Pipe Plug	1	MCR134902001
13	Pendant Assembly	1	83486
14	Pendant Body	1	MCR420237VRD
15	Hose	FT	TCS137240925
16	Warning Tag	1	WTAG7
17	Tag Holder	1	E3S787003
18	Strain Relief Cable	FT	9013120
19	Cable Tie	6	9006603
20	Boot	1	AH136608250
21	Cable Connector	2	9012301



Harrington Hoists, Inc.
401 West End Avenue
Manheim, PA 17545

www.harringtonhoists.com

Toll Free: 800-233-3010
Phone: 717-665-2000
Fax: 717-665-2861

© Harrington Hoists, Inc.
All Rights Reserved

MCROM-ENG