OWNER'S MANUAL

MOTORIZED FREE STANDING JIB CRANE 351M/352M Series

½ Ton through 5 Ton Capacity

Product Code and Serial Number

WARNING

This equipment should not be installed, operated or maintained by any person who has not read and understood all the contents of this manual. Failure to read and comply with the contents of this manual can result in serious bodily injury or death, and/or property damage.



Table of Contents

Section	Page Number
1.0 Important Information and Warnings.....	3
1.1 Terms and Summary	
1.2 Warning Tags and Labels	
2.0 Technical Information.....	6
2.1 Specifications & Dimensions	
2.2 Crane Terms	
3.0 Pre-operational Procedures.....	10
3.1 Pre-Assembly	
3.2 Mast Installation	
3.3 Head and Boom Installation	
3.4 Drive Installation	
3.5 Electrification & Final Assembly	
3.6 Bottom Entry Collector	
3.7 Flat Cable System	
3.8 Torque Limiter	
3.9 Mechanical Rotation Stops	
4.0 Operation.....	22
4.1 Introduction	
4.2 Shall's and Shall Not's for Operation	
4.3 Jib Boom Operation	
4.4 Trolley Operation	
4.5 Hoist Operation	
4.6 Shut-Down Instructions	
5.0 Inspection	26
6.0 Lubrication.....	28
6.1 Crane Lubrication	
6.2 Gear Motor Lubrication	
7.0 Troubleshooting.....	29
8.0 Warranty.....	30
9.0 Parts Information.....	31

1.0 Important Information and Warnings

1.1 Terms and Summary

This manual provides important information for personnel involved with the installation, operation and maintenance of this product. Although you may be familiar with this or similar equipment, it is strongly recommended that you read this manual before installing, operating or maintaining the product.

Danger, Warning, Caution and Notice - Throughout this manual there are steps and procedures that can present hazardous situations. The following signal words are used to identify the degree or level of hazard seriousness.

▲ DANGER Danger indicates an imminently hazardous situation which, if not avoided, **will** result in **death or serious injury**, and property damage.

▲ WARNING Warning indicates an imminently hazardous situation which, if not avoided, **could** result in **death or serious injury**, and property damage.

▲ CAUTION Caution indicates a potentially hazardous situation which, if not avoided, **may** result **minor or moderate injury** or property damage.

NOTICE Notice is used to notify people of installation, operation, or maintenance information which is important but not directly hazard-related.

▲ CAUTION

These general instructions deal with the normal installation, operation, and maintenance situations encountered with the equipment described herein. The instructions should not be interpreted to anticipate every possible contingency or to anticipate the final system, crane, or configuration that uses this equipment. For systems using the equipment covered by this manual, the supplier and owner of the system are responsible for the system's compliance with all applicable industry standards, and with all applicable federal, state and local regulations/codes.

This manual includes instructions and parts information for a variety of crane types. Therefore, all instructions and parts information may not apply to any one type or size of a specific crane. Disregard those portions of the instructions that do not apply.

Record your crane's Model and Serial Number (see Crane Drawing and **Section 9**) on the front cover of this manual for identification and future reference to avoid referring to the wrong manual for information or instructions on installation, operation, inspection, maintenance, or parts.

Use only Harrington authorized replacement parts in the service and maintenance of this crane.

WARNING

Equipment described herein is not designed for and **MUST NOT** be used for lifting, supporting, or transporting people, or for lifting or supporting loads over people.

Equipment described herein should not be used in conjunction with other equipment unless necessary and/or required safety devices applicable to the system, crane, or application are installed by the system designer, system manufacturer, crane manufacturer, installer, or user.

Modifications to upgrade, rerate, or otherwise alter this equipment shall be authorized only by the original equipment manufacturer.

Cranes, used to handle hot molten material may require additional equipment or devices. Refer to ASTM E2349 "Standard Practice for Safety Requirements in Metal Casting Operations: Sand Preparation, Molding, and Core Making; Melting and Pouring; and Cleaning and Finishing".

Only trained and competent personnel should inspect and repair this equipment. Due to the necessity of interpreting these instructions, only competent erection personnel familiar with standard fabrication practices should be employed to assemble Harrington's cranes. Harrington is not responsible for quality of workmanship performed during crane installation.

Consult with a qualified structural engineer to determine if your support structure is adequate to support the loads generated by anchor bolt force, overturning moment, or axial load of your crane.

Crane cannot be utilized as a ground: a separate ground wire is required.

Overloading and improper use can result in injury.

All welds must meet American Welding Society (AWS) specification D14.1 "Specification for Welding of Industrial and Mill Cranes and other Material Equipment."

Electrical equipment described herein is designed and built in compliance with Harrington's interpretation of ANSI/NFPA 70, "National Electrical Code". The system designer, system manufacturer, crane designer, crane manufacturer, installer, or user is responsible to assure that the installation and associated wiring of these electrical components is in compliance with ANSI/NFPA 70, and all applicable Federal, State and Local Codes.

Failure to read and comply with any one of the limitations noted herein can result in serious bodily injury or death, and/or property damage.

DANGER

HAZARDOUS VOLTAGES ARE PRESENT IN THE CONTROL BOX, OTHER ELECTRICAL COMPONENTS, AND CONNECTIONS BETWEEN THESE COMPONENTS FOR MOTORIZED JIB CRANES.

Before performing ANY mechanical or electrical maintenance on the equipment, de-energize (disconnect) the main switch supplying power to the equipment; as well as lock and tag the main switch in the de-energized position. Refer to ANSI Z244.1, "Personnel Protection – Lockout/Tagout of Energy Sources".

NOTICE

It is the responsibility of the owner/user to install, inspect, test, maintain, and operate a crane in accordance with the applicable portions of OSHA Specification 1910.179 "Overhead and Gantry Cranes," ANSI B30.11, "Monorails and Underhung Cranes," and any other applicable standards.

It is the responsibility of the owner/user to have all personnel that will install, inspect, test, maintain, and operate a crane read the contents of this manual and applicable portions of OSHA Specification 1910.179 "Overhead and Gantry Cranes," ANSI B30.11, "Monorails and Underhung Cranes," and any other applicable standards.

If the crane owner/user requires additional information, or if any information in the manual is not clear, contact Harrington or the distributor of the crane. Do not install, inspect, test, maintain, or operate this crane unless this information is fully understood.

A regular schedule of inspection of the crane in accordance with the requirements of OSHA Specification 1910.179 "Overhead and Gantry Cranes," ANSI B30.11, "Monorails and Underhung Cranes," and any other applicable standards should be established and records maintained.

Dimensions and figures contained in this manual are for reference only and may differ for your particular application. Please refer to the Foundation Drawing and Jib Crane Drawing included with crane.

1.2 Warning Tags and Labels

This crane may be part of a lifting system including a hoist and trolley. It is the responsibility of the owner of such a lifting system to ensure that the lifting system be equipped with warning labels in accordance with applicable industry standards.

2.0 Technical Information

2.1 Specifications & Dimensions

2.1.1 Product Code

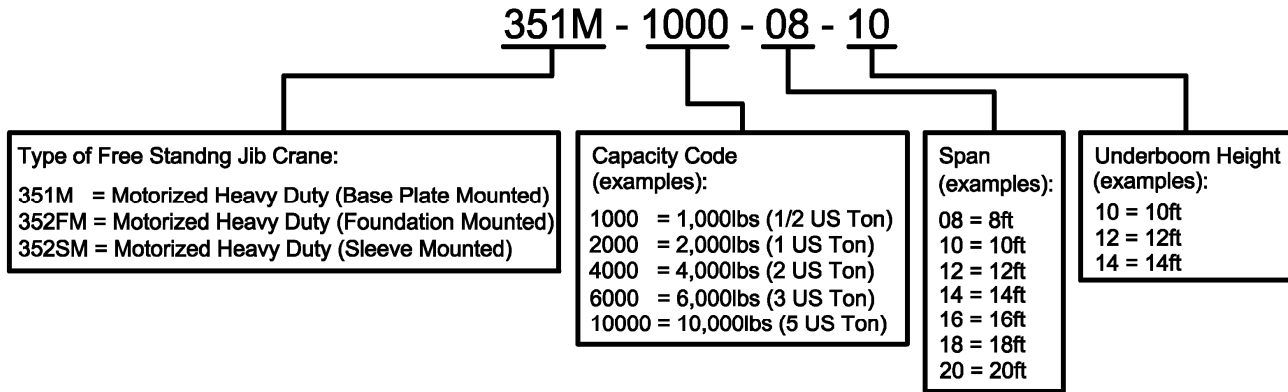

2.1.2 Operating Conditions and Environment

Temperature range: -4°F to +104°F (-20°C to 40°C)

Relative Humidity: 85% or less

Supply Voltage: Single Speed Standard: 208/230 & 460-3-60

Single Speed Optional: 575V-3-60 or Special Voltages/Frequencies Available

VFD Optional: 208/230V-3-60, 460V-3-60 or Special Voltages/Frequencies Available

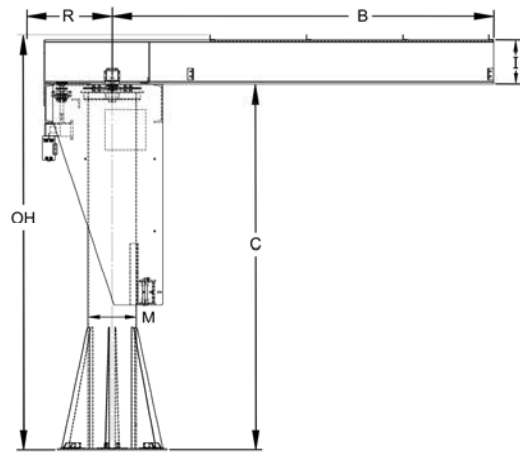

12 Hole Base Plate

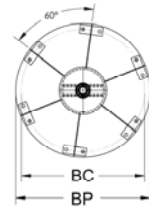

Table 2-1 Model 351M Specifications & Dimensions¹

Capacity (US Ton)	Product Code	Span B (Feet-Inches)	Underboom Height C (Feet-Inches)	Overall Height OH (Feet-Inches)	Beam Size I (Inches)	Mast Diameter M (Inches)	Rotation Clearance R (Inches)	Bolt Circle Diameter BC (Inches)	Base Plate Diameter BP (Inches)	# of Bolts	Weight (Lbs.)	Foundation (Feet)
1/2	351M-1000-08-10	8'-0"	10'-0"									
	351M-1000-10-10	10'-0"										
	351M-1000-12-10	12'-0"										
	351M-1000-14-10	14'-0"										
	351M-1000-16-10	16'-0"										
	351M-1000-18-10	18'-0"										
	351M-1000-20-10	20'-0"										
	351M-1000-08-12	8'-0"	12'-0"									
	351M-1000-10-12	10'-0"										
	351M-1000-12-12	12'-0"										
	351M-1000-14-12	14'-0"										
	351M-1000-16-12	16'-0"										
	351M-1000-18-12	18'-0"										
	351M-1000-20-12	20'-0"										
	351M-1000-08-14	8'-0"	14'-0"									
	351M-1000-10-14	10'-0"										
	351M-1000-12-14	12'-0"										
	351M-1000-14-14	14'-0"										
351M-1000-16-14	16'-0"											
351M-1000-18-14	18'-0"											
351M-1000-20-14	20'-0"											
1	351M-2000-08-10	8'-0"	10'-0"									
	351M-2000-10-10	10'-0"										
	351M-2000-12-10	12'-0"										
	351M-2000-14-10	14'-0"										
	351M-2000-16-10	16'-0"										
	351M-2000-18-10	18'-0"										
	351M-2000-20-10	20'-0"										
	351M-2000-08-12	8'-0"	12'-0"									
	351M-2000-10-12	10'-0"										
	351M-2000-12-12	12'-0"										
	351M-2000-14-12	14'-0"										
	351M-2000-16-12	16'-0"										
	351M-2000-18-12	18'-0"										
	351M-2000-20-12	20'-0"										
	351M-2000-08-14	8'-0"	14'-0"									
	351M-2000-10-14	10'-0"										
	351M-2000-12-14	12'-0"										
	351M-2000-14-14	14'-0"										
351M-2000-16-14	16'-0"											
351M-2000-18-14	18'-0"											
351M-2000-20-14	20'-0"											

Please refer to the crane drawing and foundation drawing provided with your order for specifications and dimensions

Capacity (US Ton)	Product Code	Span B (Feet- Inches)	Underboom Height C (Feet-Inches)	Overall Height OH (Feet-Inches)	Beam Size I (Inches)	Mast Diameter M (Inches)	Rotation Clearance R (Inches)	Bolt Circle Diameter BC (Inches)	Base Plate Diameter BP (Inches)	# of Bolts	Weight (Lbs.)	Foundation (Feet)
2	351M-4000-08-10	8'-0"	10'-0"									
	351M-4000-10-10	10'-0"										
	351M-4000-12-10	12'-0"										
	351M-4000-14-10	14'-0"										
	351M-4000-16-10	16'-0"										
	351M-4000-18-10	18'-0"										
	351M-4000-20-10	20'-0"										
	351M-4000-08-12	8'-0"	12'-0"									
	351M-4000-10-12	10'-0"										
	351M-4000-12-12	12'-0"										
	351M-4000-14-12	14'-0"										
	351M-4000-16-12	16'-0"										
	351M-4000-18-12	18'-0"										
	351M-4000-20-12	20'-0"										
	351M-4000-08-14	8'-0"	14'-0"									
	351M-4000-10-14	10'-0"										
	351M-4000-12-14	12'-0"										
	351M-4000-14-14	14'-0"										
351M-4000-16-14	16'-0"											
351M-4000-18-14	18'-0"											
351M-4000-20-14	20'-0"											
3	351M-6000-08-10	8'-0"	10'-0"									
	351M-6000-10-10	10'-0"										
	351M-6000-12-10	12'-0"										
	351M-6000-14-10	14'-0"										
	351M-6000-16-10	16'-0"										
	351M-6000-18-10	18'-0"										
	351M-6000-20-10	20'-0"										
	351M-6000-08-12	8'-0"	12'-0"									
	351M-6000-10-12	10'-0"										
	351M-6000-12-12	12'-0"										
	351M-6000-14-12	14'-0"										
	351M-6000-16-12	16'-0"										
	351M-6000-18-12	18'-0"										
	351M-6000-20-12	20'-0"										
	351M-6000-08-14	8'-0"	14'-0"									
	351M-6000-10-14	10'-0"										
	351M-6000-12-14	12'-0"										
	351M-6000-14-14	14'-0"										
351M-6000-16-14	16'-0"											
351M-6000-18-14	18'-0"											
351M-6000-20-14	20'-0"											
5	351M-10000-08-10	8'-0"	10'-0"									
	351M-10000-10-10	10'-0"										
	351M-10000-12-10	12'-0"										
	351M-10000-14-10	14'-0"										
	351M-10000-16-10	16'-0"										
	351M-10000-18-10	18'-0"										
	351M-10000-20-10	20'-0"										
	351M-10000-08-12	8'-0"	12'-0"									
	351M-10000-10-12	10'-0"										
	351M-10000-12-12	12'-0"										
	351M-10000-14-12	14'-0"										
	351M-10000-16-12	16'-0"										
	351M-10000-18-12	18'-0"										
	351M-10000-20-12	20'-0"										
	351M-10000-08-14	8'-0"	14'-0"									
	351M-10000-10-14	10'-0"										
	351M-10000-12-14	12'-0"										
	351M-10000-14-14	14'-0"										
351M-10000-16-14	16'-0"											
351M-10000-18-14	18'-0"											
351M-10000-20-14	20'-0"											

Please refer to the crane drawing and foundation drawing provided with your order for specifications and dimensions

Note: 1 - Other spans, capacities, under boom height, etc. are available. Contact Customer Service.

2.2 Crane Terms

In order to better understand jib cranes, here are the commonly used terms that are used to specify and design jibs:

- **Anchor Bolts:** Large steel bolts used to mount a base mounted pillar jib crane to the Harrington recommended foundation.
- **Boom:** The horizontal beam on which the hoist trolley travels.
- **Fitting Centers:** The distance, centerline to centerline, between two support brackets (fittings) of a wall mounted jib crane.
- **Capacity:** The maximum live weight that the crane is designed to support.
- **End Stops:** Bolted to each end of the boom to prevent the trolley from falling off of the beam.
- **Foundation:** For free standing pillar base mounted jibs. Foundations are used to support the jib and prevent it from tipping over.
- **Gussets:** Reinforcing plates used to stiffen mast at the base plate.
- **Head:** Houses the roller, and lowers the crushing forces that are imposed on the mast.
- **Height Under the Boom (H.U.B.):** The distance from the finished floor to the underside of the crane boom. To find the underboom, take the height of the load, plus the distance the load is lifted, plus the headroom requirements of the hoist/trolley and any attachments. Extra room in addition to the minimum required H.U.B. may be helpful for crane operations.
- **Mast:** The vertical member of the jib, which supports the crane. Pillar jibs have round pipes as masts.
- **Overall Height:** The highest point of the jib crane (including any hardware). A minimum clearance (usually 3") is required from any overhead obstruction.
- **Hoist:** The actual lifting mechanism (powered by electric, air, or manual movement) that hangs from the trolley that rides on the boom of a jib crane.
- **Trolley:** The mechanism that travels back and forth on the crane boom (powered by electric, air, or manual movement) which the hoist hangs from.
- **Overtipping Moment:** The force applied to the mounting structure of a self-supporting pillar jib. This force is caused by suspending a load from the boom, and is at maximum with full load at the end of the boom.
- **Rotation Stops:** Limits the rotation of a pillar base mounted jib crane boom (which are standard at 360°). Stops are field welded to the mast.
- **Span:** The span for a pillar base mounted jib crane is the distance from the center of the mast to the end of the boom. The span for a column mounted crane is measured from the face of the mounting surface to the end of the boom. The span for a mast type jib crane is measured from the center of the vertical mast to the end of the boom.
- **Thrust and Pull:** Thrust and Pull are forces applied to a wall/column mounted jib cranes support structure. Thrust is the pushing force exerted on the structure, and pull is the tensile, or pulling force. Thrust and Pull are equal to each other (but opposite in direction), and are given at maximum with full load at the end of the boom.
- **Clear Span:** The measurement between the end stops on a crane boom.
- **Hook Travel:** The distance that the hook on the hoist travels.

3.0 Preoperational Procedures

3.1 Pre-Assembly

- 3.1.1 Check jib crane for physical damage due to shipping.
- 3.1.2 Ensure all capacity stickers and warning labels are clearly visible and properly affixed.
- 3.1.3 Check packing list to ensure no parts have been lost prior to initiating assembly of crane.
- 3.1.4 See Foundation Drawing and Jib Crane Drawing for bolt locations and dimensions.
- 3.1.5 Read entire manual before installing the crane.
- 3.1.6 Identify crane model (351M, 352FM, 352SM) - See **Figure 3-1**, **Figure 3-2**, and **Figure 3-3**. Find the applicable assembly instructions in **Section 3.2** based on your jib crane model type.

⚠ CAUTION Figures are for reference only and may differ for your particular application. Reference Foundation Drawing and Jib Crane Drawing included with crane information packet for specific information.

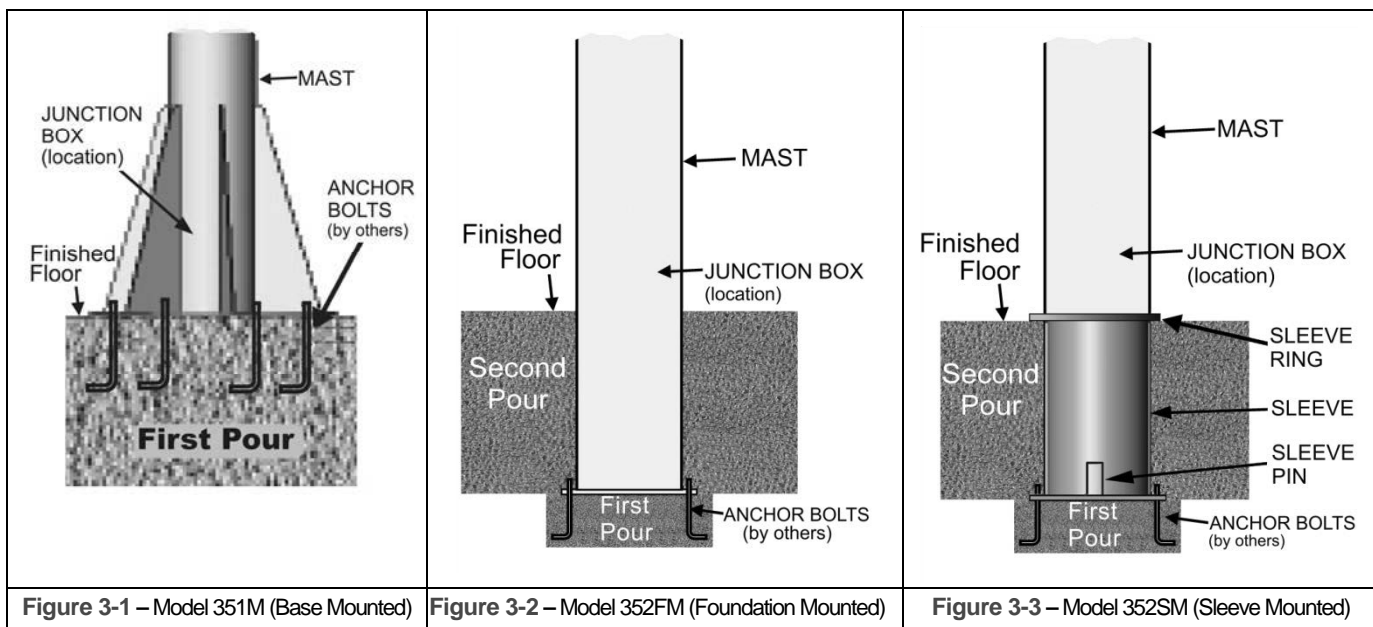

3.2 Mast Installation

- 3.2.1 **⚠ WARNING** If multiple cranes were ordered, locate stamped serial number on each crane part for proper part matching during installation. Although crane parts may appear to be identical, each crane is assembled and built separately. All parts that do not have the same stamped serial number may not line up properly for installation.
- 3.2.2 **⚠ WARNING** Consult a qualified structural engineer to determine that your support structure is adequate to support the loads generated by anchor bolt force, overturning moment, or axial load of your crane. Suggested foundation requirements and curing times are recommendations only. Because conditions may vary, consult a qualified professional to verify foundation requirements.
- 3.2.3 **NOTICE** Recommended jib crane foundation requirements are based on a soil pressure of 2500 lbs. per square foot. Recommended concrete for jib crane foundation is 3000 lbs. per square inch of compressive force.
- 3.2.4 **NOTICE** Recommended curing time for foundation/concrete before mast installation is 10 days. Recommended curing time for foundation/concrete before loading crane to full capacity is 28 days.

3.2.5 **For Model 351M: Base Mounted (See Figure 3-1):**

- 1) Reference Foundation Drawing and Jib Crane Drawing included in the jib crane information packet.
- 2) Pour foundation with ANCHOR BOLTS located according to BASE PLATE bolt pattern. Ensure the proper length of ANCHOR BOLT is exposed above floor level (see Foundation Drawing).
- 3) After foundation is properly cured, spread grout over foundation approximately 1" thick & same diameter as BASE PLATE (see Foundation Drawing). Grout must be a non-shrink, high compressive machinery type grout.
- 4) Lift and position MAST over ANCHOR BOLTS. Locate JUNCTION BOX on MAST and position to desired location.
- 5) Lower MAST over ANCHOR BOLTS and set on foundation grout surface in desired location (see **Figure 3-1**). Tighten ANCHOR BOLTS until MAST is plumb in all directions (see **Figure 3-6**). Grout is soft and will allow BASE PLATE to settle for plumbing procedure.

⚠ WARNING

Plumbing of mast assembly is very important and will affect performance of jib crane

- 6) After grout has properly cured, fully tighten ANCHOR BOLTS to manufacturer's specification. Verify that the MAST is still plumb.
- 7) Wrap DRIVE CHAIN around MAST SPROCKET located on top plate of MAST. Position chain ends towards back side of the MAST for access during BOOM/HEAD installation. Roll ends of chain in towards MAST SPROCKET to prevent damaging during BOOM/HEAD installation (see **Figure 3-8**).
- 8) Locate THRUST BEARING, lubricate with high grade grease and set on BEARING PIN at the top of the MAST (see **Figure 3-7**).
- 9) Proceed to **Section 3.3** to install the HEAD and BOOM ASSEMBLY.

3.2.6 **For Model 352F: Heavy Duty – Foundation Mounted (See Figure 3-2):**

- 1) Reference Foundation Drawing and Jib Crane Drawing included in the jib crane information packet.
- 2) Excavate proper sized area to prepare for crane foundation (see Foundation Drawing).
- 3) First Pour – Refer to Foundation Drawing for anchor bolt location to set ANCHOR BOLTS in first pour.
- 4) After concrete has hardened and ANCHOR BOLTS are set, spread mechanical grout over mounting area approximately 1-1/4" thick. Grout must be a non-shrink, high compressive machinery type grout.
- 5) Lift and position MAST over ANCHOR BOLTS. Locate JUNCTION BOX on MAST and position to desired location.
- 6) Lower MAST over ANCHOR BOLTS and set on foundation grout surface in desired location (see **Figure 3-2**). Make sure JUNCTION BOX location will be above finished floor and will not interfere with second concrete pour. Tighten ANCHOR BOLTS until MAST is plumb in all directions (see **Figure 3-6**). Grout is soft and will allow for proper plumbing of MAST.

⚠ WARNING

Plumbing of mast assembly is very important and will affect performance of jib crane.

- 7) After grout has properly cured, fully tighten ANCHOR BOLTS to manufacturer's specifications so that MAST does not move during second pour. Verify MAST is still plumb.
- 8) Second Pour - After MAST is set and grout has dried, reference Foundation Drawing and proceed with second pour using reinforcing rods as shown on the Foundation Drawing. Make sure concrete from second pour has properly cured before proceeding.
- 9) Locate THRUST BEARING, lubricate with high grade grease and set on BEARING PIN at the top of the MAST (see **Figure 3-7**).
- 10) Wrap DRIVE CHAIN around MAST SPROCKET located on top plate of MAST. Position chain ends towards back side of mast for access during BOOM/HEAD installation. Roll ends of chain in towards MAST SPROCKET to prevent damaging during BOOM/HEAD installation (see **Figure 3-8**).
- 11) Proceed to **Section 3.3** to install the HEAD and BOOM ASSEMBLY.

3.2.7 For Model 352S: Heavy Duty – Sleeve Mounted (See Figure 3-3):

- 1) Reference Foundation Drawing and Jib Crane Drawing included in the jib crane information packet.
- 2) Excavate proper sized area to prepare for crane foundation (see Foundation Drawing).
- 3) First Pour – Refer to Foundation Drawing for location to set ANCHOR BOLTS in first pour.
- 4) After concrete has hardened and ANCHOR BOLTS are set, spread mechanical grout over mounting area approximately 1-1/4" thick. Grout must be a non-shrink, high compressive machinery type grout.

⚠ WARNING Plumbing of sleeve is very important and will affect performance of jib crane.

- 5) Install SLEEVE and tighten bolts making sure the SLEEVE is plumb in all directions (see **Figure 3-6**). Grout is soft and will allow for proper plumbing of SLEEVE.
- 6) After grout has properly cured, fully tighten ANCHOR BOLTS to manufacturer's specifications so that SLEEVE does not move during second pour. Verify SLEEVE is still plumb.
- 7) Second Pour - Reference Foundation Drawing and proceed with second pour using reinforcing rods as shown on Foundation Drawing. Make sure SLEEVE RING is resting on top of poured foundation (see **Figure 3-3**)

After Concrete has Properly Cured:

- 8) Lift and position MAST into place over SLEEVE. Locate JUNCTION BOX on MAST and position to desired location.
- 9) Insert MAST into SLEEVE and allow the bottom hole of MAST to slide over SLEEVE PIN (see **Figure 3-4**)

⚠ WARNING Plumbing of mast assembly is very important and will affect performance of jib crane.

- 10) Plumb MAST in all directions (see **Figure 3-6**). Make sure MAST remains plumb throughout **step 11**.
- 11) Place SPLIT RINGS provided around bottom part of MAST resting on top of SLEEVE RING (see **Figure 3-5**). Tack weld SPLIT RING into position to MAST and SLEEVE RING. After SPLIT RING is tack welded into proper position check once more that mast has remained plumb then weld SPLIT RING all around MAST and weld SPLIT RING completely around to SLEEVE RING. Verify MAST is still plumb.
- 12) Locate THRUST BEARING, lubricate with high grade grease and set on BEARING PIN at the top of the MAST (see **Figure 3-7**).
- 13) Wrap DRIVE CHAIN around MAST SPROCKET located on top plate of MAST. Position chain ends towards back side of MAST for access during BOOM/HEAD installation. Roll ends of chain in towards MAST SPROCKET to prevent damaging during BOOM/HEAD installation (see **Figure 3-8**).
- 14) Proceed to **Section 3.3** to install HEAD and BOOM ASSEMBLY.

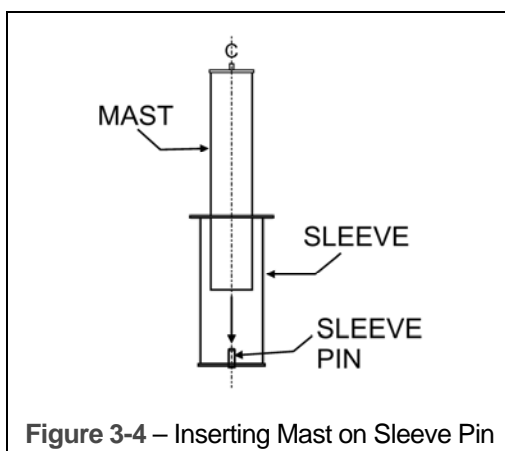

Figure 3-4 – Inserting Mast on Sleeve Pin

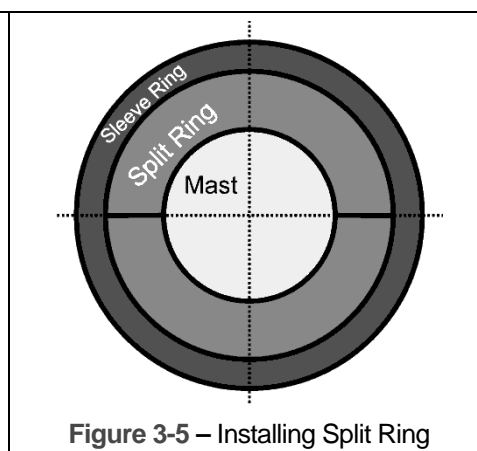
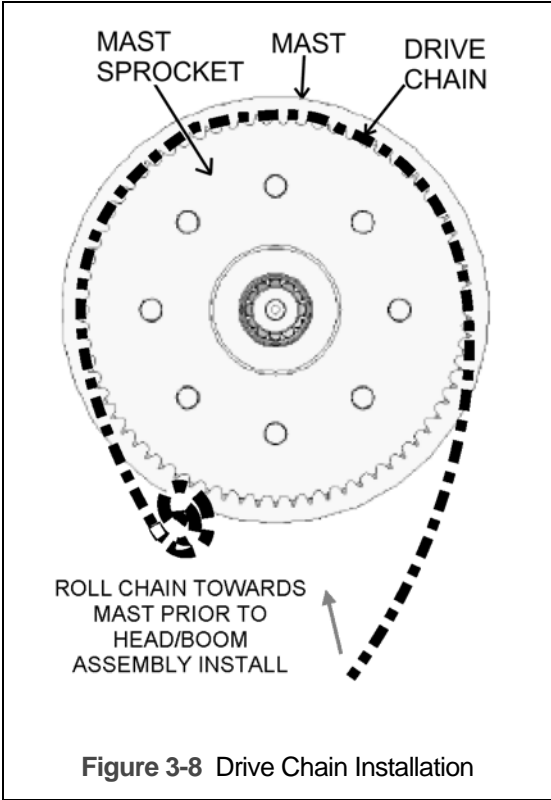
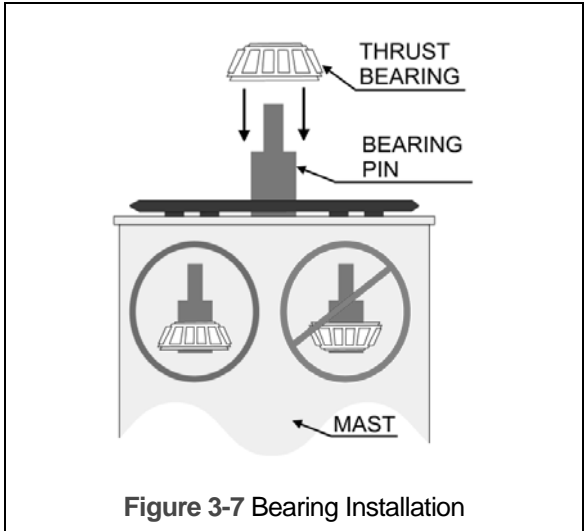
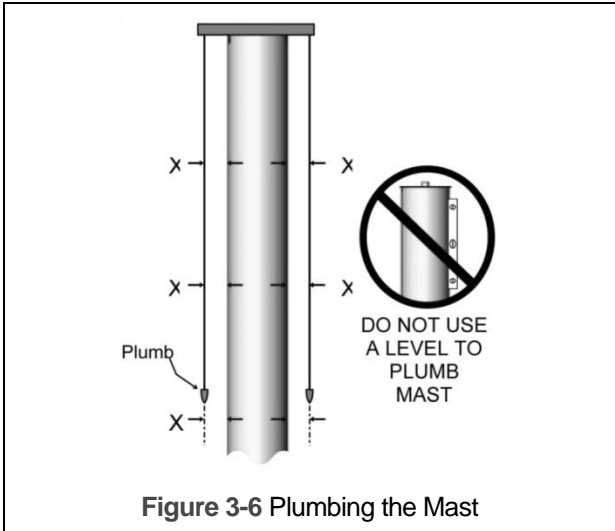

Figure 3-5 – Installing Split Ring



3.3 Head and Boom Installation

- 3.3.1 Reference **Figure 3-9** for general assembly layout. Reference Jib Crane Drawing for bolt sizes and locations.
- 3.3.2 Check the BEARING HOUSING on BOOM for proper amount of grease before continuing installation
- 3.3.3 Depending on size of crane and machinery available for installation, the BOOM and HEAD ASSEMBLY can be pre-assembled for mounting to MAST. Use the following procedure if this is the desirable installation method (if an alternative method is preferred, continue to **Step 3.3.4**).
- 1) Bolt the BOOM to HEAD ASSEMBLY at BOOM BACK PLATE and FRONT SUPPORT with bolts provided.
 - 2) Lift entire assembly (BOOM and HEAD) so that BOOM is as level as possible to easily set over top of the MAST and BEARING PIN. (Remove SPACER RODS if necessary).
 - 3) **▲ CAUTION** Secure wires in BEARING PIN and ensure that DRIVE CHAIN is out of the way before attempting the next **step 3.3.3.4**
 - 4) Lower BOOM and HEAD ASSEMBLY over MAST ensuring that BEARING PIN goes through the center of BEARING HOUSING. Continue to lower assembly over THRUST BEARING ensuring that BEARING HOUSING is properly seated on THRUST BEARING.
 - 5) **NOTICE** Ensure that wires are not sheared or stripped and that the DRIVE CHAIN was not damaged during HEAD/BOOM ASSEMBLY install.
 - 6) Replace SPACER RODS if removed (continue to **Step 3.3.5**).
- 3.3.4 Installation of HEAD ASSEMBLY and BOOM in separate pieces:
- 1) Lift HEAD ASSEMBLY over top of the MAST and BEARING PIN. (Remove SPACER RODS if necessary).
 - 2) **▲ CAUTION** Secure wires in BEARING PIN and ensure that DRIVE CHAIN is out of the way before attempting the next **step 3.3.3.3 and step 3.3.3.4**.
 - 3) Place HEAD ASSEMBLY on MAST with the top plate of HEAD ASSEMBLY resting on top plate of MAST. Be sure that the THRUST BEARING is centered in HEAD ASSEMBLY's top plate cut-out. Remove SPACER RODS if necessary.
 - 4) Set BOOM on top of THRUST BEARING making sure BEARING HOUSING is properly seated on THRUST BEARING.
 - 5) **NOTICE** Ensure that wires are not sheared or stripped and that the DRIVE CHAIN was not damaged during HEAD/BOOM install.
 - 6) Fasten BOOM to HEAD ASSEMBLY using bolts provided at BOOM BACK PLATE and FRONT SUPPORTS. See torque specs in **Table 3-1**.
 - 7) Replace SPACER RODS if removed (continue to **Step 3.3.5**).
- 3.3.5 Lubricate rollers in ROLLER CAGE ASSEMBLY with high grade grease.
- 3.3.6 Under no load condition, adjust the BOOM so that the far end of the boom is $\text{span(in.)}/300$ above the horizontal. To adjust desired BOOM elevation, loosen and tighten TENSION BOLTS on ROLLER CAGE ASSEMBLY while moving the tip of BOOM up or down. Ensure rollers are making full contact with MAST.
- 3.3.7 Proceed to **Section 3.4** for Drive Installation.

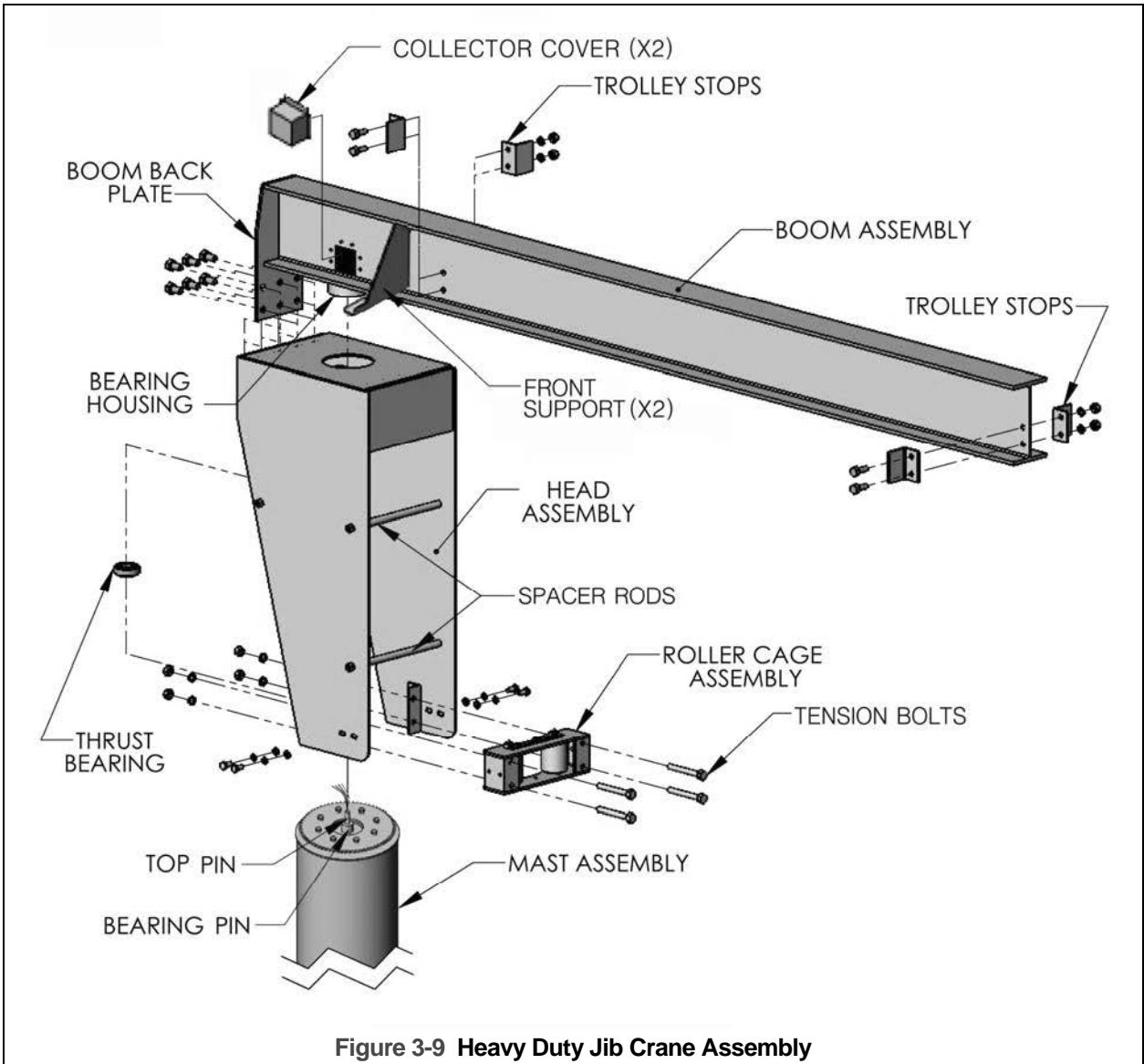
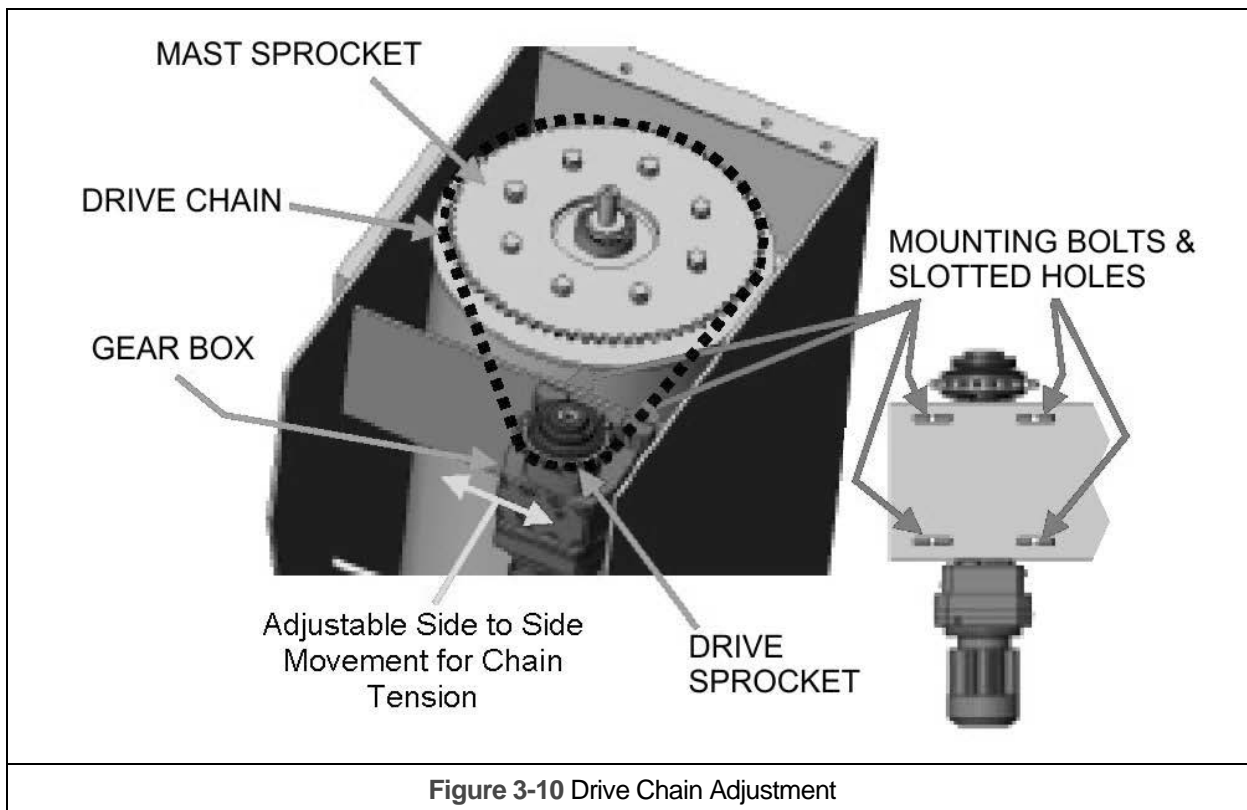

Figure 3-9 Heavy Duty Jib Crane Assembly

Table 3-1 Torque Specifications	
BOLT DIA.	TORQUE
1/4" - 20	6 ft.-lbs.
3/8" - 16	20 ft.-lbs.
1/2" - 13	50 ft.-lbs.
5/8" - 11	95 ft.-lbs.
3/4"-10	175 ft.-lbs.
7/8" - 9	300 ft.-lbs.

3.4 Drive Installation

- 3.4.1 Loosen MOUNTING BOLTS for gear box. Move GEAR BOX inwards towards the center line of the MAST using the slotted holes. (see Figure 3-10)
- 3.4.2 Wrap DRIVE CHAIN around MAST SPROCKET with chain ends toward DRIVE SPROCKET to permit connection, connect chain around DRIVE SPROCKET using half or full link provided.
- 3.4.3 Adjust DRIVE CHAIN to proper tension by re-positioning GEAR BOX in slotted holes, and then tighten MOUNTING BOLTS.
- 3.4.4 Check all bolt connections including ANCHOR BOLTS and tighten if necessary.
- 3.4.5 Proceed to Section 3.5 for Electrification



3.5 Electrification & Final Assembly

⚠ WARNING Do not bring main power into the JUNCTION BOX on mast until installation is complete

- 3.5.1 Install BOTTOM ENTRY COLLECTOR (see **Section 3.6**)
- 3.5.2 Install FLAT CABLE system. If applicable, install independent traveling PB station. (See **Section 3.7**)
- 3.5.3 Bolt two inner TROLLEY STOPS to BOOM (see **Figure 3-9**). Slide Hoist/Trolley onto BOOM, then bolt two remaining TROLLEY STOPS to BOOM.
- 3.5.4 Connect FLAT CABLE wires to HOIST/TROLLEY through cord grip/connector. Wire hoist/trolley using wiring diagram or wire labels if interfacing was purchased
- 3.5.5 Wire WIRELESS RADIO REMOTE SYSTEM to hoist/trolley (if applicable).
- 3.5.6 Check all wire connections with wiring diagrams provided
- 3.5.7 Check brake and motor wiring in jib motor for proper voltage hook up.
- 3.5.8 Check through the door disconnect for proper function and set in OFF position prior to applying power.
- 3.5.9 With jib power source OFF, bring main power into JUNCTION BOX on MAST.
- 3.5.10 Turn power ON and check MAINLINE CONTACTOR function.
- 3.5.11 Rotate BOOM slowly and check around 360° degrees for binds or slow down spots. Remove interference if any.
- 3.5.12 Check phasing for proper rotation direction
- 3.5.13 Check the flat cable system operation by running the entire flat cable system back and forth several times over the entire track length to ensure proper operation. Ensure that festooning cannot be snagged or pinched.

⚠ WARNING Be sure that the cable loop from the lead trolley saddle to the hoist/trolley connections does not place any side pull on the lead trolley. Cable must clear all other equipment.

- 3.5.14 Test all motions first without load, then with load.

3.5.15 **⚠ WARNING** If any malfunctions occur, power off system immediately and trouble shoot system (See Trouble shooting guide in **Section 7.0**)

3.5.16 **⚠ WARNING** All motorized systems should be wired from a lockable fused safety disconnect (by others) for shut down during emergency or maintenance)

3.5.17 If applicable, weld rotational limit switch baffles at desired locations on the MAST. Make sure they will align and make contact with the limit switch (located inside the head assembly underneath the control panel)

⚠ WARNING Turn OFF system power during baffle installation.

3.5.18 If applicable, install limit switch arm on the end of the pre-installed limit switch. Test for functionality of limit switch after crane installation is complete and before crane is put in service.

3.5.19 **⚠ WARNING** Read gear motor manual before crane use

3.5.20 **⚠ WARNING** Read VFD drive instruction manual before crane use (if applicable)

3.5.21 **⚠ CAUTION** Refer to VFD drive instruction manual for any error codes (if applicable)

3.5.22 If applicable, install MECHANICAL ROTATION STOPS (note: these are only supplied as a back up to a rotational limit switch – See **Section 3.10**).

3.5.23 Adjust TORQUE LIMITER to proper torque before applying load to jib crane (see **Section 3.8**).

NOTICE If the torque limiter is not set correctly, the drive sprocket may slip and the crane may not rotate properly

3.5.24 Please call Product Support with any questions during install.

3.6 Bottom Entry Collector

- 3.6.1 Refer to Figures 3-9, 3-11, and 3-12.
- 3.6.2 Secure COLLECTOR to the CUT-OUT PLATE by pulling the wires sticking out of the TOP PIN through the COLLECTOR and slide COLLECTOR onto the TOP PIN.
- 3.6.3 Tighten COLLECTOR to CUT-OUT PLATE using the BOLTS provided. Do not tighten two BOLTS completely to COLLECTOR. Tighten two NUTS on underside of CUT-OUT PLATE to secure COLLECTOR
- 3.6.4 Tighten the COLLECTOR RING COLLAR to the TOP PIN using two SET SCREWS with 1/8" hex wrench.
- 3.6.5 Before connecting wires, rotate BOOM to make sure COLLECTOR is functioning properly. Make adjustments if needed.
- 3.6.6 Connect wires sticking out of TOP PIN to the four wires from the COLLECTOR. Be sure to connect each wire from the BEARING PIN to the proper numbered wire on the COLLECTOR.
- 3.6.7 Punch hole into COLLECTOR COVER at desired location to bring power to CONTROL PANEL.
- 3.6.8 Connect whip from CONTROL PANEL to knock out of COLLECTOR COVER using proper sized cord grip/connector.
- 3.6.9 Connect power cord wires to the proper termination points on the exterior of the collector's frame
- 3.6.10 Fasten COLLECTOR COVERS to beam using bolts provided.

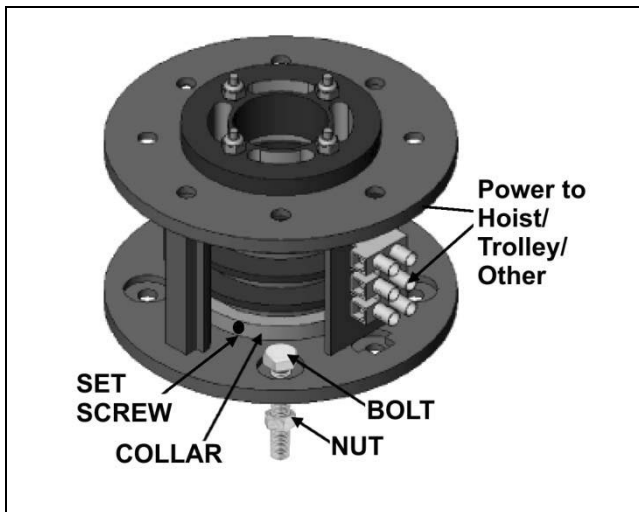

Figure 3-11 Bottom Entry Collector

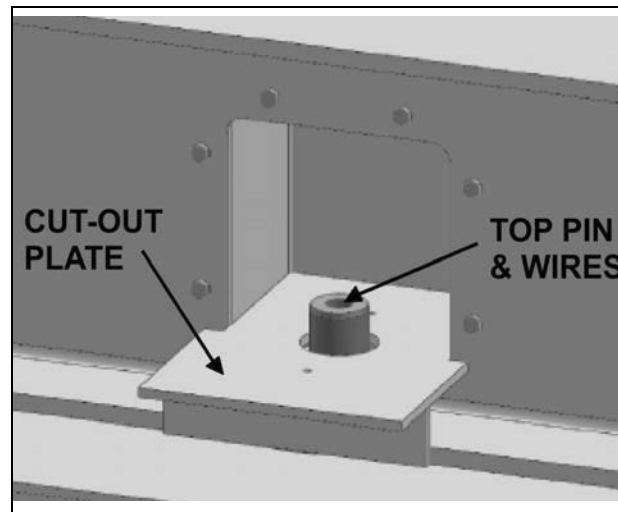

Figure 3-12 Bottom Entry Collector Location

3.7 Flat Cable System

- 3.7.1 **⚠ WARNING** Make sure power supply is disconnected before installing, repairing, or working in the proximity of any electrical system. Only qualified electrical personnel should install or repair the electrification/flat cable system.
- 3.7.2 Reference **Figure 3-13**.
- 3.7.3 Install SUPPORT ANGLES to top of I beam using bolts provided.
- 3.7.4 Install TRACK HANGERS on CROSSARM SUPPORTS. Leave the clamping bolts loose.
- 3.7.5 Install one TRACK ANCHOR HANGER in place of the standard TRACK HANGER at the end CROSSARM SUPPORT
- 3.7.6 Slide C-TRACK sections into TRACK HANGERS. Butt C-TRACK CHANNELS together and secure with TRACK JOINTS. Firmly tighten TRACK JOINT clamping bolts, TRACK HANGER clamping bolts, and ANCHOR HANGER bolts ensuring that the C-TRACK is straight.
- 3.7.7 Install the END CLAMP onto the cable-storage end of the track.
- 3.7.8 Insert INTERMEDIATE TROLLEYS into the C-TRACK. Be sure all trolleys float freely within the track.
- 3.7.9 Insert TOW TROLLEY as the last of the trolleys. When installing a "Push Button" track, install the CONTROL UNIT TROLLEY as the last of the trolleys on that track.
- 3.7.10 Install the END STOP on the track end opposite the END CLAMP. Securely tighten the nut.
- 3.7.11 If applicable, install the provided tow chain on the equipment to be electrified and attach it to the TOW TROLLEY. If a tow arm was ordered, it should be centered within the TOW TROLLEY.
- 3.7.12 Connect festooning flat cable to pre-drilled knock out hole in CONTROL PANEL using provided cord grip. Make wire connections in CONTROL PANEL.
- 3.7.13 If applicable, connect 12C flat cable from junction box on CONTROL UNIT TROLLEY to pre-drilled knock out hole in CONTROL PANEL using pre-attached cord grip. Make wire connections in CONTROL PANEL.

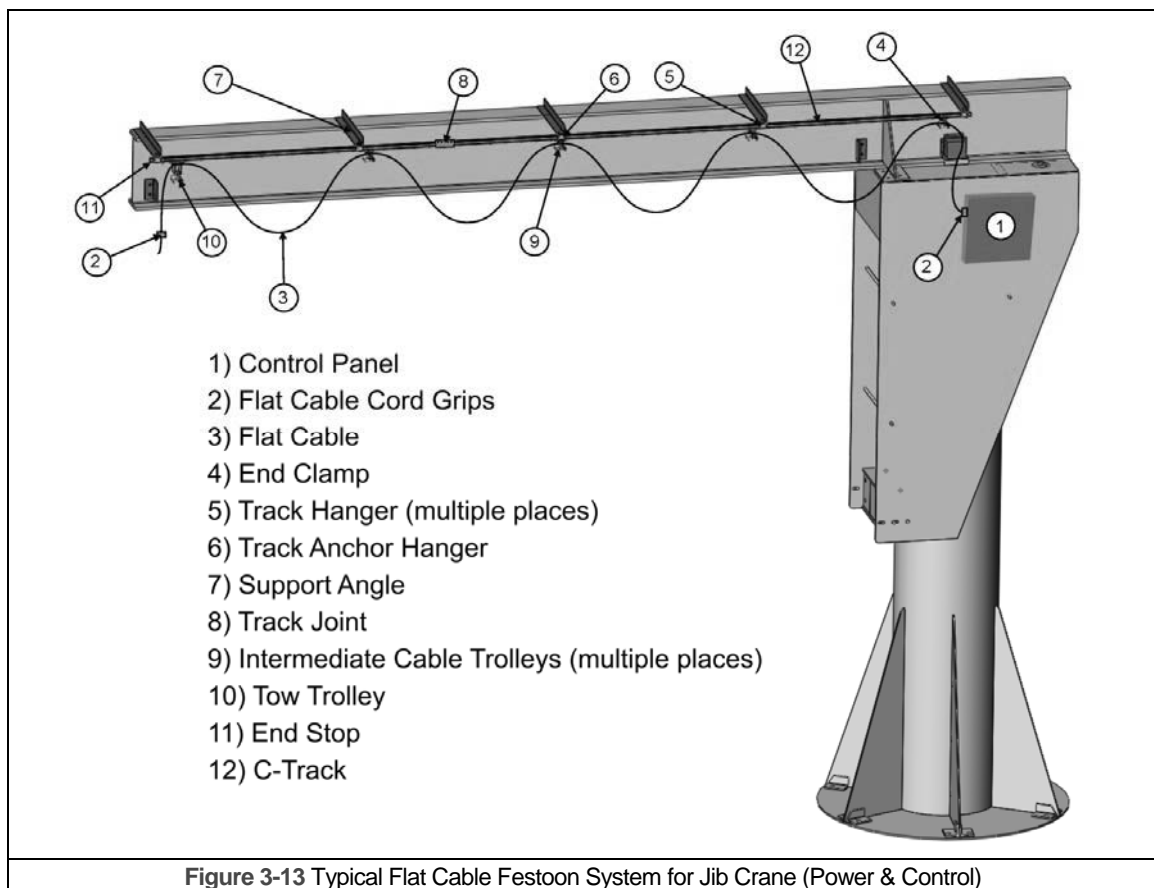

Figure 3-13 Typical Flat Cable Festoon System for Jib Crane (Power & Control)

3.8 Torque Limiter

3.8.1 Installation (see Figure 3-14)

- 1) In addition to the Torque Limiter, obtain a center member, usually a sprocket. Ensure that it is finished according to the specifications shown in the literature. Select a bushing to fit the bore and width of the center member.
- 2) Back off the three ADJUSTING NUT SCREWS four full turns.
- 3) Remove the ADJUSTING NUT, SPRING RETAINER, SPRING, PRESSURE PLATE, and one FRICTION DISC.
- 4) Ensure that the FRICTION DISCS are free of oil or moisture.
- 5) Install the BUSHING over the HUB and pilot the center member over the bushing. Re-assemble the friction disc, pressure plate with the smooth side to the friction disc, spring, spring retainer with pilot facing the spring, and the adjusting nut.
- 6) Advance the ADJUSTING NUT to a finger tight position, ensuring that the SPRING is piloted on the SPRING RETAINER.

3.8.2 Run in Procedure (see Figure 3-14)

- 7) It is recommended that the unit be "run in" by slipping the center member.
- 8) Ensure that the three ADJUSTING NUT SCREWS are backed off four turns and that the ADJUSTING NUT is in a finger tight position.
- 9) Match mark the ADJUSTING NUT and HUB. Back off the ADJUSTING NUT 1 ½ turns for the 500 model, or 2 ¼ turns for the 700 model. Tighten the three ADJUSTING NUT SCREWS alternately until the heads bottom.
- 10) Slip the center member for 3-4 minutes at approximately 60 rpm.
- 11) Install the Torque Limiter on the shaft with a key and tightens the SET SCREW in the HUB.

3.8.3 To Adjust Torque (see Figure 3-14)

- 12) Ensure that the three ADJUSTING NUT SCREWS are backed off four full turns and that the ADJUSTING NUT is in a finger tight position.
- 13) Match mark the ADJUSTING NUT with the HUB. Back off the ADJUSTING NUT the number of turns that correspond to the desired break away torque as shown in Table 3-2).
- 14) Tighten the three ADJUSTING NUT SCREWS alternately until the heads bottom

Model	No. of springs	Approximate Break Away Torque (LB-FT)			
500	1	90	150	200	250
	2	120	300	350	400
TURNS		1 ½	1	¾	0
700	1	300	400	530	620
	2	450	600	750	900
TURNS		2	1 ¾	1 ¼	0

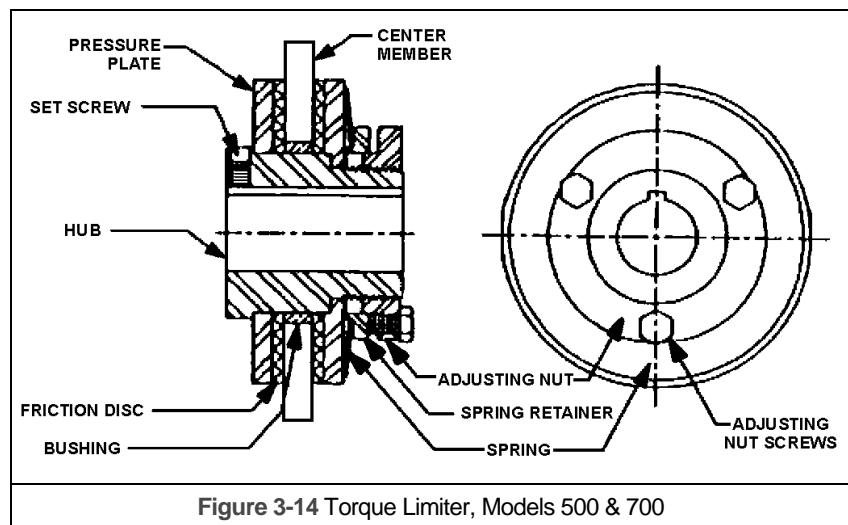
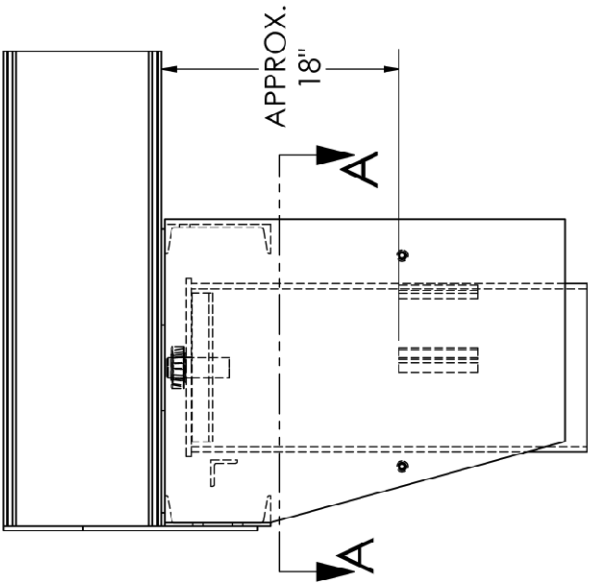
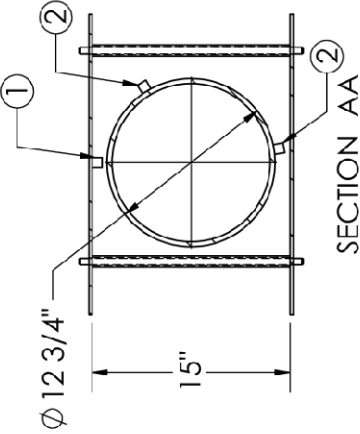

Figure 3-14 Torque Limiter, Models 500 & 700

3.9 Mechanical Rotation Stops

62900





NOTES:

1. MECHANICAL ROTATION STOPS WILL PERMIT 359° OF ROTATION.
2. ITEM 1 WELDED TO HEAD AT LOCATION SHOWN BY MANUFACTURER.
3. ITEM 2 SHIPPED LOOSE TO BE LOCATED & WELDED TO PIPE MAST ASSEMBLY IN FIELD AT DESIRED POSITION.
4. WHEN ERECTING CRANE, NOTE RELATIONSHIP OF BAR STOP INSIDE HEAD TO BAR ON MAST ASSEMBLY FOR PROPER ORIENTATION OF STOP.

ITEM NO.	PART NUMBER	DESCRIPTION	QTY
1	TT9164500	3/4" SQUARE BAR 6" L	1
2	TT9164500	3/4" SQUARE BAR 6" L	2



TIGER TRACK

DESCRIPTION: MECHANICAL ROTATION STOPS (12 3/4" DIA PIPE)			
PART NUMBER	62900	MATERIAL	
DRAWN BY	D. Grujic	DATE DRAWN	11/14/07
		DRAWING SIZE	A
		SHEET NUMBER	1
		SCALE	1:12

TOLERANCES: DECIMALS (UNLESS OTHERWISE SPECIFIED) TWO PLACE (.00) + / .015 THREE (.000) + / .005 ANGLES + / 30 MINUTES. ALL DIMENSIONS ARE IN INCHES UNLESS OTHERWISE SPECIFIED.

4.0 Operation

4.1 Introduction

The suggestions below are not intended to take precedence over existing plant safety rules and regulations or OSHA regulations. It is the responsibility of the owner to make personnel aware of all federal, state and local rules and codes, and to make certain operators are properly trained.

DANGER

DO NOT WALK UNDER A SUSPENDED LOAD
KEEP HANDS CLEAR OF ROTATING PARTS

WARNING

CRANE OPERATORS SHALL BE REQUIRED TO READ THE OPERATION SECTION OF THIS MANUAL, THE WARNINGS CONTAINED IN THIS MANUAL, INSTRUCTION AND WARNING LABELS ON THE CRANE OR LIFTING SYSTEM, APPLICABLE ANSI AND OSHA SAFETY STANDARDS, AND THE CRANE OPERATOR'S MANUAL PUBLISHED BY THE CRANE MANUFACTURER'S ASSOCIATION OF AMERICA (CMAA). THE OPERATOR SHALL ALSO BE REQUIRED TO BE FAMILIAR WITH THE CRANE AND CRANE CONTROLS BEFORE BEING AUTHORIZED TO OPERATE THE CRANE OR LIFTING SYSTEM.

CRANE OPERATORS SHOULD BE TRAINED IN PROPER RIGGING PROCEDURES FOR THE ATTACHMENT OF LOADS TO THE HOIST HOOK.

CRANE OPERATORS SHOULD BE TRAINED TO BE AWARE OF POTENTIAL MALFUNCTIONS OF THE EQUIPMENT THAT REQUIRE ADJUSTMENT OR REPAIR, AND TO BE INSTRUCTED TO STOP OPERATION IF SUCH MALFUNCTIONS OCCUR, AND TO IMMEDIATELY ADVISE THEIR SUPERVISOR SO CORRECTIVE ACTION CAN BE TAKEN.

CRANE OPERATORS SHOULD HAVE NORMAL DEPTH PERCEPTION, FIELD OF VISION, REACTION TIME, MANUAL DEXTERITY, HEARING, AND COORDINATION.

CRANE OPERATORS SHOULD **NOT** HAVE A HISTORY OF OR BE PRONE TO SEIZURES, LOSS OF PHYSICAL CONTROL, PHYSICAL DEFECTS, OR EMOTIONAL INSTABILITY THAT COULD RESULT IN ACTIONS OF THE OPERATOR BEING A HAZARD TO THE OPERATOR OR TO OTHERS.

CRANE OPERATORS SHOULD **NOT** OPERATE A CRANE OR LIFTING SYSTEM WHEN UNDER THE INFLUENCE OF ALCOHOL, DRUGS, OR MEDICATION.

NOTICE

- Read OSHA Specification 1910.179 "Overhead and Gantry Cranes," ANSI B30.11, "Monorails and Underhung Cranes," ASME B30.16, and any other applicable standards.
- Read the hoist manufacturer's Operating and Maintenance Instructions.
- Read all labels attached to equipment.

4.2 Shall's and Shall Not's for Operation

WARNING

Improper operation of a crane can create a potentially hazardous situation which, if not avoided, could result in death or serious injury, and substantial property damage. To avoid such a potentially hazardous situation **THE OPERATOR SHALL:**

- **NOT** operate a damaged, malfunctioning or unusually performing crane.
- **NOT** operate a crane until you have thoroughly read and understood Manufacturer's Operating and Maintenance Instructions or Manuals.
- Be familiar with operating controls, procedures, and warnings.
- **NOT** operate a crane that has been modified without the manufacturer's approval
- **NOT** lift more than rated load for the crane/hoist/trolley.
- **NOT** use the crane to lift, support, or transport people.
- **NOT** lift loads over people.
- **NOT** operate a crane unless all persons are and remain clear of the supported load.
- **NOT** operate unless load is centered under hoist.
- **NOT** leave load supported by the crane/hoist unattended unless specific precautions have been taken.
- **NOT** allow the crane to be used as an electrical or welding ground.
- **NOT** remove or obscure the warnings on the crane.
- **NOT** operate a crane on which the safety placards or decals are missing or illegible.
- **NOT** operate a crane that has any changes in rolling effort or unusual noises.
- Warn personnel before lifting or moving a load.
- Warn personnel of an approaching load.
- Ensure that end stops are in place.
- Ensure that all bolts are tight and have lock washers.
- **NOT** put hands near rotating parts.

CAUTION

Improper operation of a crane can create a potentially hazardous situation which, if not avoided, could result in minor or moderate injury, or property damage. To avoid such a potentially hazardous situation **THE OPERATOR SHALL:**

- Maintain a firm footing or be otherwise secured when operating the crane.
- Make sure the load is free to move and will clear all obstructions.
- Avoid swinging the load or hook.
- Inspect the crane regularly, replace damaged or worn parts, and keep appropriate records of maintenance.
- Use the crane manufacturer's recommended parts when repairing the unit.
- Lubricate the roller bearings per crane manufacturer's recommendations.
- Lubricate drive unit parts per manufacturer's recommendations.
- **NOT** use limit switches as routine operating stops. They are back up devices only.
- **NOT** allow your attention to be diverted from operating the crane.
- **NOT** allow the crane to be subjected to sharp contact with other cranes, structures, or objects through misuse.
- **NOT** adjust or repair the crane unless qualified to perform such adjustments or repairs.
- Ensure that festooning cannot be snagged or pinched.

4.3 Jib Boom Operation

- 4.3.1 Verify the hook is high enough to clear any obstruction before using the boom of the jib crane.
- 4.3.2 Ensure the jib boom is directly over the load before lifting the load.
- 4.3.3 Start moving the jib boom slowly and bring it up to speed gradually.
- 4.3.4 Reduce the speed of the boom as it approaches the desired position.

4.4 Trolley Operation

Refer to the trolley's operating instructions.

4.5 Hoist Operation

Refer to the hoist's operating instructions.

4.6 Shut-Down Instructions

Whenever the operator leaves the crane, the procedure below should be followed:

- 4.6.1 Raise all hooks to an intermediate position.
- 4.6.2 Spot the crane at an approved designated location
- 4.6.3 Secure the beam in the shut-down position or storage area. If the crane is an outdoor application and it has a tie down loop, secure tightly especially in high wind areas.
- 4.6.4 Check the crane, hoist, and hook storage positions to be sure there is no interference with other pieces of equipment that may be operating in the area.
- 4.6.5 Place all controls in the "**OFF**" position
- 4.6.6 Turn the main switch to the "**OFF**" position.
- 4.6.7 Make a visual check before leaving the crane.

This Page Intentionally Left Blank

5.0 Inspection

5.1 Crane Inspection

⚠ WARNING When inspecting any electrical equipment (flat cable system, control panel, junction box, entry collector, etc.), use proper lockout/tagout procedures before performing the inspection.

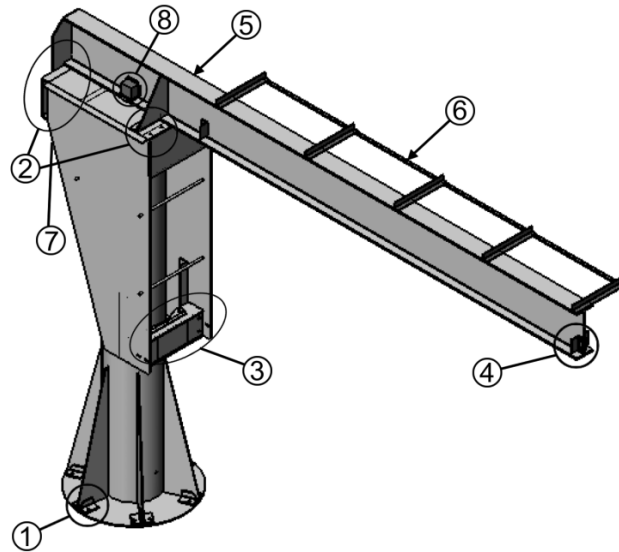

Table 5-1 Crane Inspection

Fig. No.	Item	Inspection	Frequency
1	Anchor Bolts	Check that lock-washers are fully compressed and nuts are tightened to manufacturer's specifications.	Every 500 hours Or 3 months
2	Boom & Head Hardware	Check that the lock-washers are fully compressed and the nuts are tightened to the proper torque specs from Table 3-1..	Every 500 hours Or 3 month
3	Thrust Bearings	Make sure both roller bearings are evenly touching the mast, adjust if needed. Grease if needed.	Every 1000 hours Or 6 months
4	End Stop	Check that the lock-washers are fully compressed and the nuts are tightened to the proper torque specs from Table 3-1.	Every 500 hours Or 3 months
5	Leveling Boom	Verify that the end of the boom is at the point of span(in.)/300 above level.	Every 1000 hours Or 6 months
6	Flat Cable System	Check all rollers for wear. Check that the lock-washers are fully compressed and the nuts are tightened to manufacturer's specifications. Check cable clamps on all trolleys (ensure cables remain secure. Inspect cable for any cuts or cracks, check C-channel for wear, and clear the running surface of debris.	Every 500 hours Or 3 months
7	Gear Motor	See Table 5-2 in Gear Motor Supplement	-
8	Entry Collector	Check brushes for wear-replace if less than 0.093" (see Fig 5-1); ensure contact surfaces are free of dirt, oxidation, pitting, etc.. Replace springs whenever brushes are replaced. Check brush spring pressure to assure uniformity (see Table 5-2) Ensure brushes fit square on the ring. Ensure slip ring surface is free of dirt, oxidation, and other contaminants. Only clean with clean, dry air or polishing kit. Inspect enclosure for moisture and dirt, clean with lint free cloth as required. Refer to manufacturer's specifications for more detail. Note: All bearings are lubricated for life from factory.	200-400 hours
-	Additional Items	Conduct a general inspection of all additional items you may have purchased.	Every 1000 hours Or 6 months
-	General	Conduct a visual inspection of the crane overall and speak with the crane operator about the crane's performance, if any flaws are noticed take crane out of service and report to manufacturer immediately.	Every 1000 hours Or 6 months

▲ WARNING

Any changes in rolling effort or unusual noises must be immediately identified and corrected.

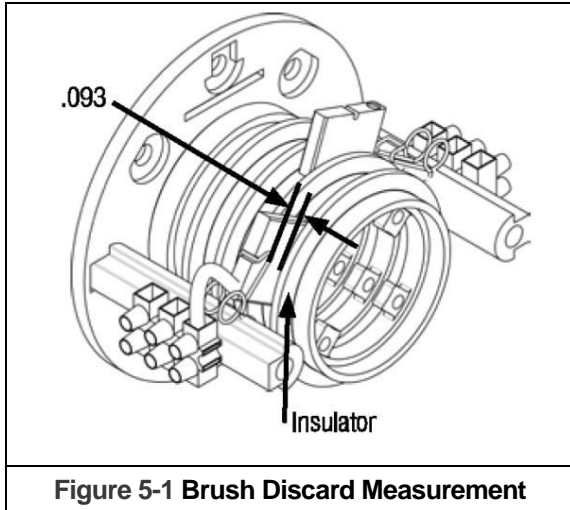

Figure 5-1 Brush Discard Measurement

Slip Ring Rating	Min. Spring Tension
15 amp	1.5 lb
35 amp	2.0 lb

6.1 Crane Lubrication

- 6.1.1 The most economical way to maintain a jib crane and keep it in good operating condition is to lubricate all moving parts regularly.
- 6.1.2 Regular inspection of all parts should be made and all loose parts should be adjusted. Parts that become worn should be replaced immediately.
- 6.1.3 The lubrication interval varies with the use of the machine. A crane operating 24 hours a day, 7 days a week, should demand lubrication once a week. Whereas a standard duty crane, operating eight hours a day on a five day week should be lubricated once every two to three weeks. Cranes under a standby classification, being used once or twice a month, should be lubricated at least once every six months.
- 6.1.4 The actual interval from one lubrication to the next depends entirely upon the type and length of operation to which the crane is subjected. These factors are variable and sometimes cannot be definitely determined. In this case, the crane operator or maintenance engineer would determine when the crane should be lubricated.
- 6.1.5 The roller bearings on the jib crane require lubrication. They are serviced by pressure type fittings.
- 6.1.6 The recommended lubricants for these bearings are:
 - Texaco Marfax No. 0 for below 32 degrees F
 - Texaco Marfax No. 1 for above 32 degrees F
- 6.1.7 If Texaco products are not available, equivalent lubricants are satisfactory.

6.2 Gear Motor Lubrication

see Section 6.2 in Gear Motor Supplement

7.0 Troubleshooting

Symptom	Cause	Remedy
Jib crane does not rotate	AC contactor coil does not pull in (or does not stay pulled in) when "ON" is pressed	Verify there are no blown fuses in jib panel. Verify pendant wiring is intact. Verify the control transformer fuse did not blow. Check for drive controller alarm.
	Motor shaft is not turning (with TEFC motors, if fan is blowing air, then motor shaft is turning)	Verify motor leads are secure.
	Shaft or drive reducer does not turn	Tighten torque limiter
	Drive controller has an error code	Note error code and reference remedy in drive controller manual
Jib crane rotates in one direction only	Pendant wiring is damaged	Verify pendant wiring is intact.
	Torque limiter is not properly adjusted	Adjust torque limiter (see Section 3.8)
	Limit switch is not properly wired	Properly wire limit switch (see Wiring Diagram)
Jib crane boom tip will not adjust to span (in.)/300	Bearing housing on boom is not properly seated on the thrust bearing	Properly seat bearing housing on thrust bearing
Jib crane does not rotate smoothly	Rollers are not making flush contact with the mast	Adjust roller cage pitch by loosening the side bolts (do not remove) on the head assembly that hold the cage in position; then tighten or loosen the top and/or bottom tension bolts to adjust the pitch of the rollers
Jib crane does not rotate a complete rotation	Crane boom has an obstruction	Remove any obstruction
	Bearing housing on boom is not properly seated on the thrust bearing	Properly seat bearing housing on thrust bearing

8.0 Warranty

All products sold by Harrington Hoists, Inc. are warranted to be free from defects in material and workmanship from date of shipment by Harrington for the following periods:

- 1 year – Electric and Air Powered Hoists (excluding (N)ER2 Enhanced Features Models), Powered Trolleys, Powered Tiger Track Jibs and Gantries, Crane Components, Below the Hook Devices, Spare / Replacement Parts**
- 2 years – Manual Hoists & Trolleys, Beam Clamps**
- 3 years – (N)ER2 Enhanced Features Model Hoists**
- 5 years – Manual Tiger Track Jibs and Gantries, TNER Pull - Rotor Motor Brake**
- 10 years – (N)ER2 “The Guardian” Smart Brake**

The product must be used in accordance with manufacturer’s recommendations and must not have been subject to abuse, lack of maintenance, misuse, negligence, or unauthorized repairs or alterations.

Should any defect in material or workmanship occur during the above time period in any product, as determined by Harrington Hoist’s inspection of the product, Harrington Hoists, Inc. agrees, at its discretion, either to replace (not including installation) or repair the part or product free of charge and deliver said item F.O.B. Harrington Hoists, Inc. place of business to customer.

Customer must obtain a Return Goods Authorization as directed by Harrington or Harrington’s published repair center prior to shipping product for warranty evaluation. An explanation of the complaint must accompany the product. Product must be returned freight prepaid. Upon repair, the product will be covered for the remainder of the original warranty period. Replacement parts installed after the original warranty period will only be eligible for replacement (not including installation) for a period of one year from the installation date. If it is determined there is no defect, or that the defect resulted from causes not within the scope of Harrington’s warranty, the customer will be responsible for the costs of returning the product.

Harrington Hoists, Inc. disclaims any and all other warranties of any kind expressed or implied as to the product’s merchantability or fitness for a particular application. Harrington will not be liable for death, injuries to persons or property or for incidental, contingent, special or consequential damages, loss or expense arising in connection with the use or inability whatever, regardless of whether damage, loss or expense results from any act or failure to act by Harrington, whether negligent or willful, or from any other reason.

9.0 Parts Information

When ordering Parts, please provide the crane serial number which is stamped into each crane part (see **Figure 9-1**). The serial number is also located underneath the “Tiger Track” logo.

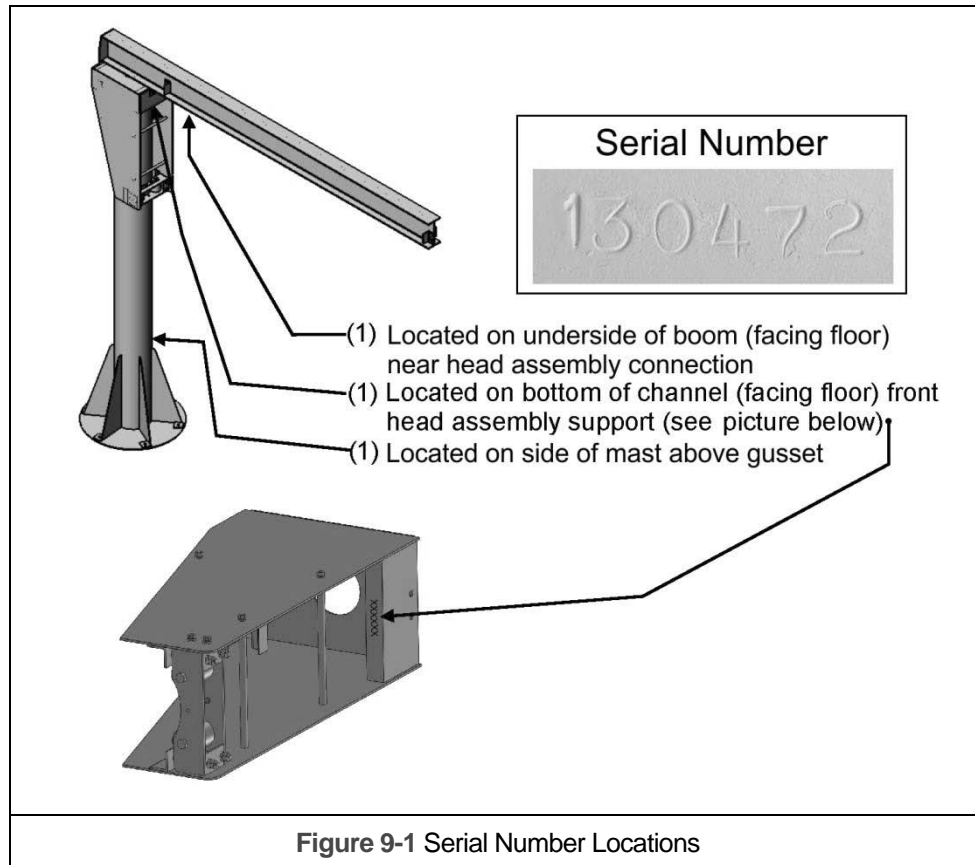

The parts list is arranged into the following sections:

Section	Page
9.1 Jib Crane Parts.....	32
9.2 Roller Cage Assembly Parts.....	36
9.3 Control Panel	38
9.4 Flat Cable.....	40
9.5 Labels.....	42

9.1 Jib Crane Parts

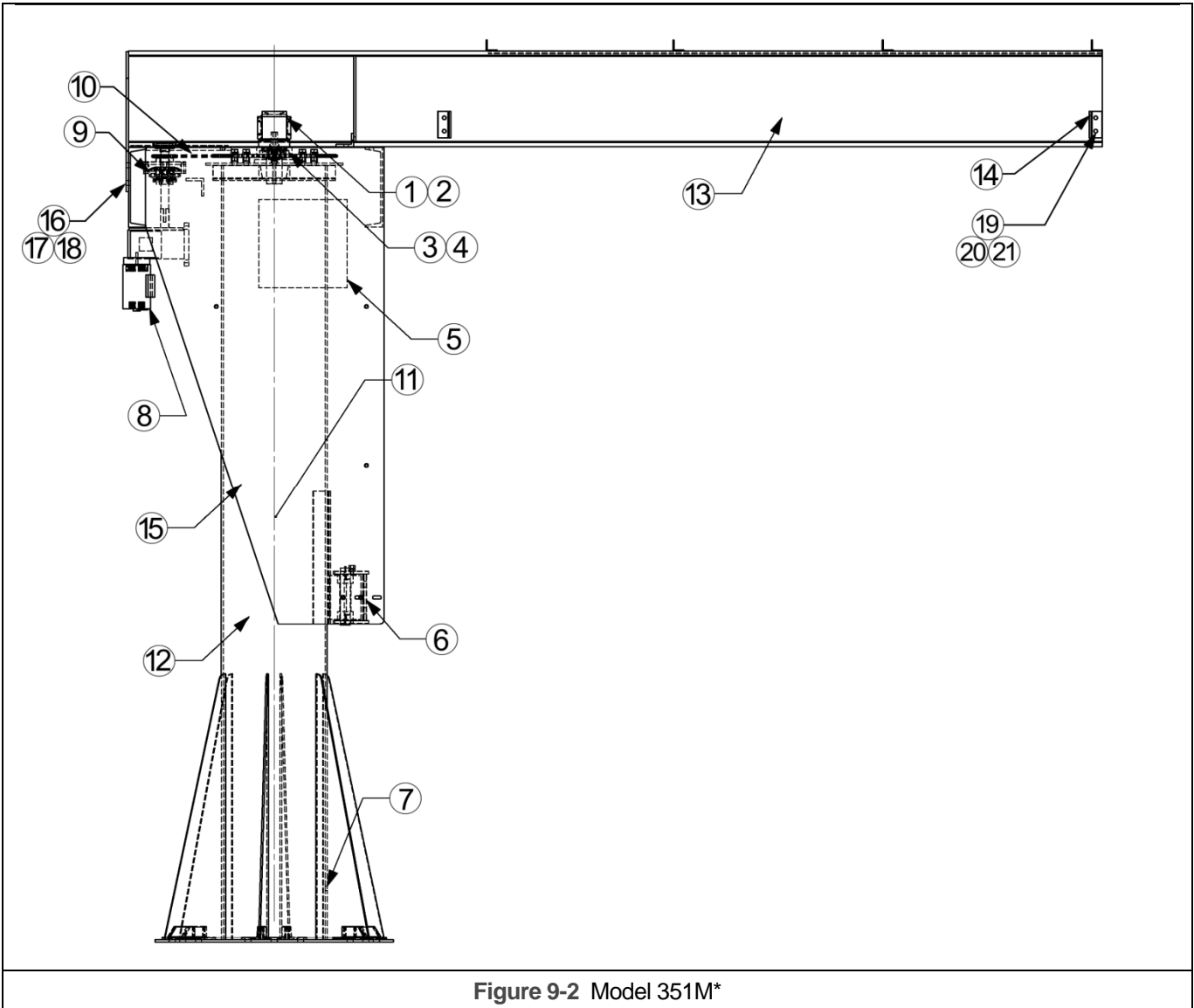

Figure 9-2 Model 351M*

*Model 351M is shown for reference, but figure numbers apply for 352SM and 352FM

9.1 Jib Crane Parts

			MAST DIAMETER, "M" (INCHES)								
Fig. No.	Description	Qty	8-5/8"	10-3/4"	12-3/4"	14"	16"	18"	20"	24"	30"
1	Bottom Entry Collector	1	TT9011455								
2	Collector Cover	2	TT9011459								
3	Top Thrust Bearing	1	TTHS3381TB				TTHS6379TB			CALL FACTORY	
4	Thrust Bearing Cone	1	TTHS3320CN				TTHS6320CN			CALL FACTORY	
5	Control Panel Enclosure	SS	TTA16148CHFL								
		VFD	TTCSD24168								
6	Roller Cage Assembly	1	TT-0110803A	TT-0111003A	TT-0111203A	TT-0111405A	TT-0111604A	TT-0111803A	TT-0112003A	TT-0112404A	TT-0113004A
7	Junction Box	1	TT9005604								
11	Wiring	Fig #7 to #1	TT10AWG								
		Fig #5 to #8	TT14AWG								
12	Mast	1	SEE BILL OF MATERIALS INCLUDED WITH CRANE								
13	Boom	1									
14	Trolley Stops	4									
15	Head Assembly	1									
16	Bolt	-									
17	Lock washer	-									
18	Nut	-									
19	Bolt	-									
20	Lock Washer	-									
21	Nut	-									

			RATED CAPACITY				
Figure No.	Description	Qty	1/2 TON (UP TO 20' SPAN)	1 TON (UP TO 20' SPAN)	2 TON (UP TO 20' SPAN)	3 TON (UP TO 20' SPAN)	5 TON (UP TO 20' SPAN)
8	Drive Unit Complete Assembly	1	TTR67R37		TTR77R37	TTR87R57	
9	Torque Limiter	1	TT500A		TT700A80	TT700A	
10	Drive Chain	FT	TT60ARC		TT80ARC	TT100ARC	

9.2 Roller Cage Assembly Parts

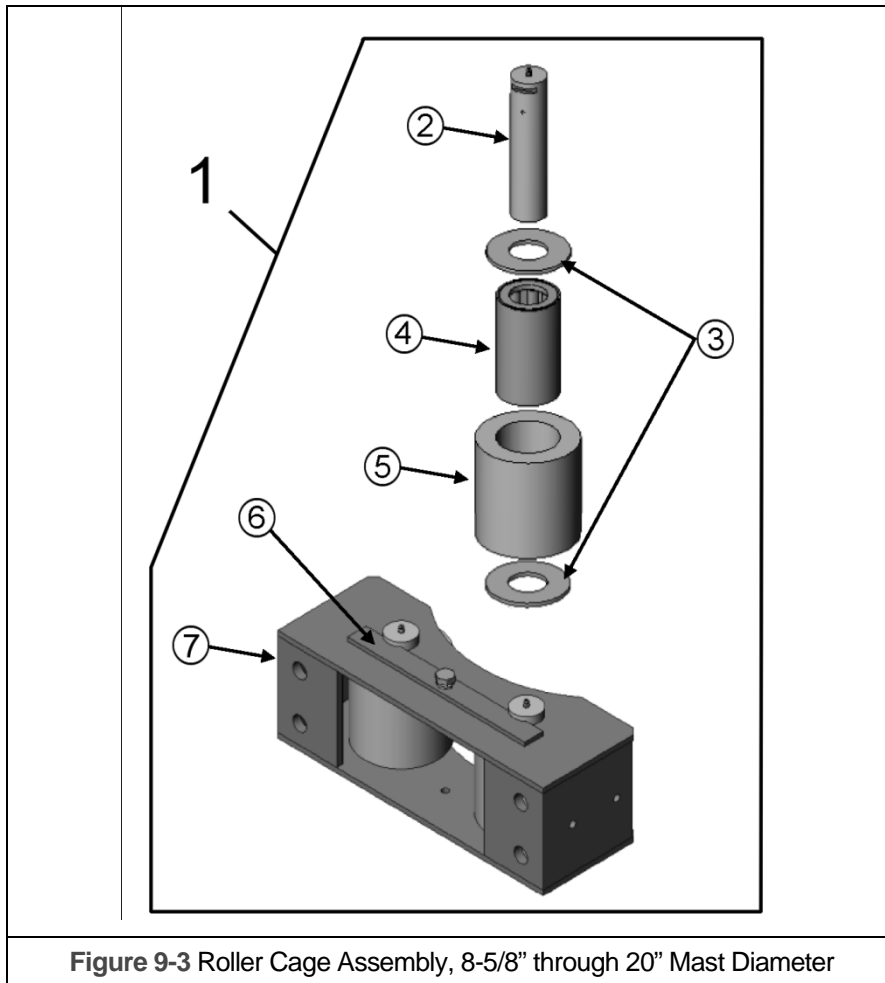

Figure 9-3 Roller Cage Assembly, 8-5/8" through 20" Mast Diameter

9.2 Roller Cage Assembly Parts

			MAST DIAMETER (INCHES)						
Figure No.	Description	Qty	8-5/8"	10-3/4"	12-3/4"	14"	16"	18"	20"
1	Roller Cage Assembly	1	TT0110803A	TT0111003A	TT0111203A	TT0111405A	TT0111604A	TT0111803A	TT0112003A
2	Roller Pin with grease fitting	2	TT0191201			TT0191402	TT0191603		
3	Flat Spacer Washer	4	TT097112501			TT097143801	TT097175001		
4	Roller Bearing	2	TT0700664			TT0700964	TT0700980		
5	Roller	2	TT0181201			TT0181402	TT0181603		
6	Keeper Bar	1	TT2190801	TT2251201		TT2254101	TT2251601	TT2251801	TT2252001
7	Roller Cage Weldment	1	TT0110803	TT0111003	TT0111203	TT0111405	TT0111604	TT0111803	TT0112003

9.2 Roller Cage Assembly Parts

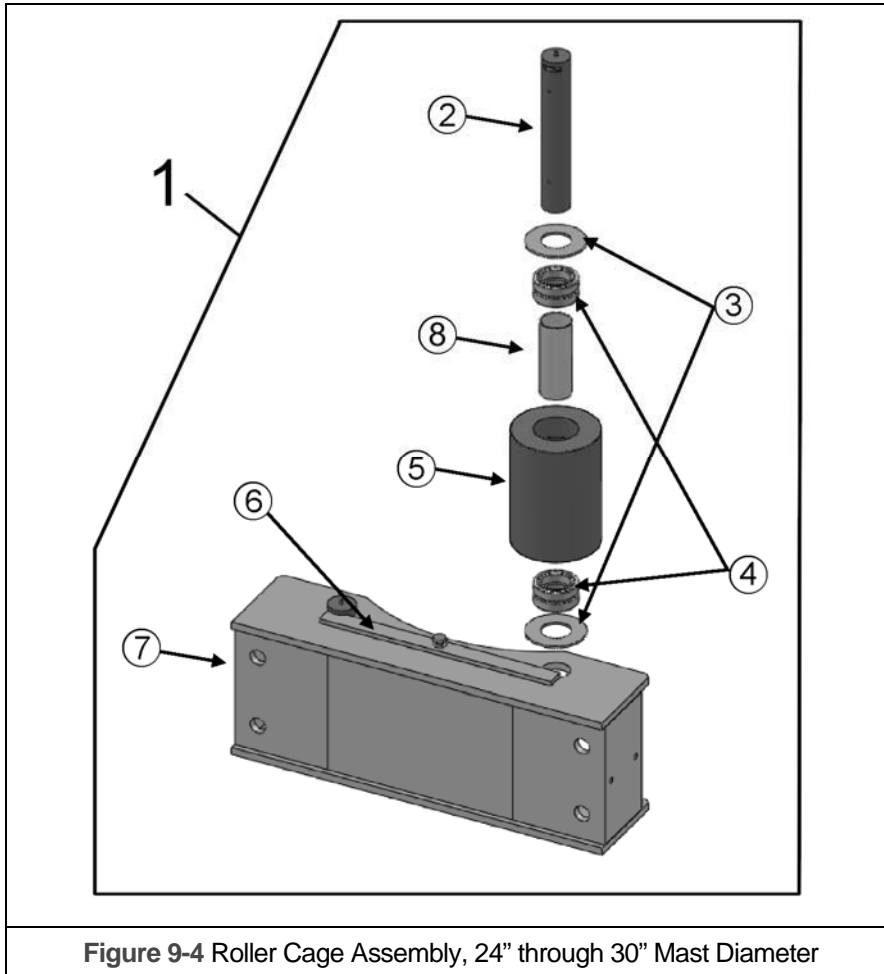

Figure 9-4 Roller Cage Assembly, 24" through 30" Mast Diameter

9.2 Roller Cage Assembly Parts

Figure No.	Description	Qty	MAST DIAMETER (INCHES)	
			24"	30"
1	Roller Cage Assembly	1	TT0112404A	TT0113004A
2	Roller Pin with Zirk Fitting	2	TT0192404	TT0193005
3	Flat Spacer Washer	4	TT097200001	TT097225001
4	Roller Bearing	4	TT0704031	TT0704436
5	Roller	2	TT0182404	TT0183005
6	Keeper Bar	1	TT2252401	TT2383001
7	Roller Cage Weldment	1	TT0112404	TT0113004
8	Bearing Spacer	2	TT0182414	TT0183015

9.3 Control Panel

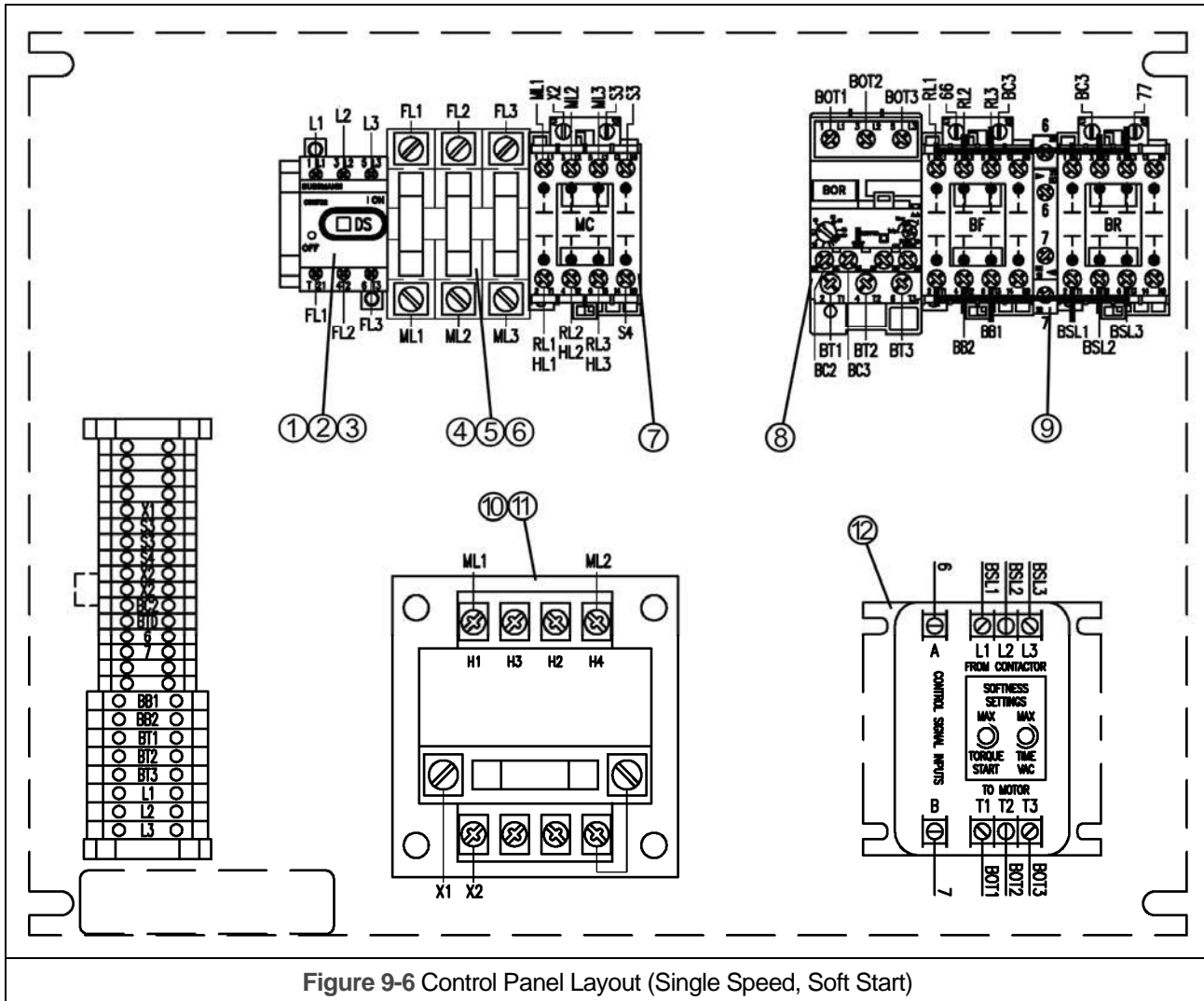

Figure 9-6 Control Panel Layout (Single Speed, Soft Start)

9.3 Control Panel

Figure No.	Description	Qty	Part Number
1	Selector Switch	1	TTCDH5S
2	30A Non-Fuse	1	TTCDNF32
3	Operating Shaft	1	TTCDS180S
4	Fuse Block, 30amp	1	TTBM6033PQ
5	Fuse, Time Delay 30amp	3	TTFNQ 30
6	Din Rail Clip	2	TTDRA1
7	Main line contactor, 30amp	1	TT100-C30D10
8	Overload Relay, 3.2-16	1	TT193-EEDB
9	Reversing Contactor	1	TT104-C09D22
10	Transformer, 80VA 460/230	1	TT1497-BBASX1N
11	Transformer Fuse, Time Delay	1	TTFNM 1
12	Soft Start, 4amp	1	TTSM4A1S

9.3 Control Panel

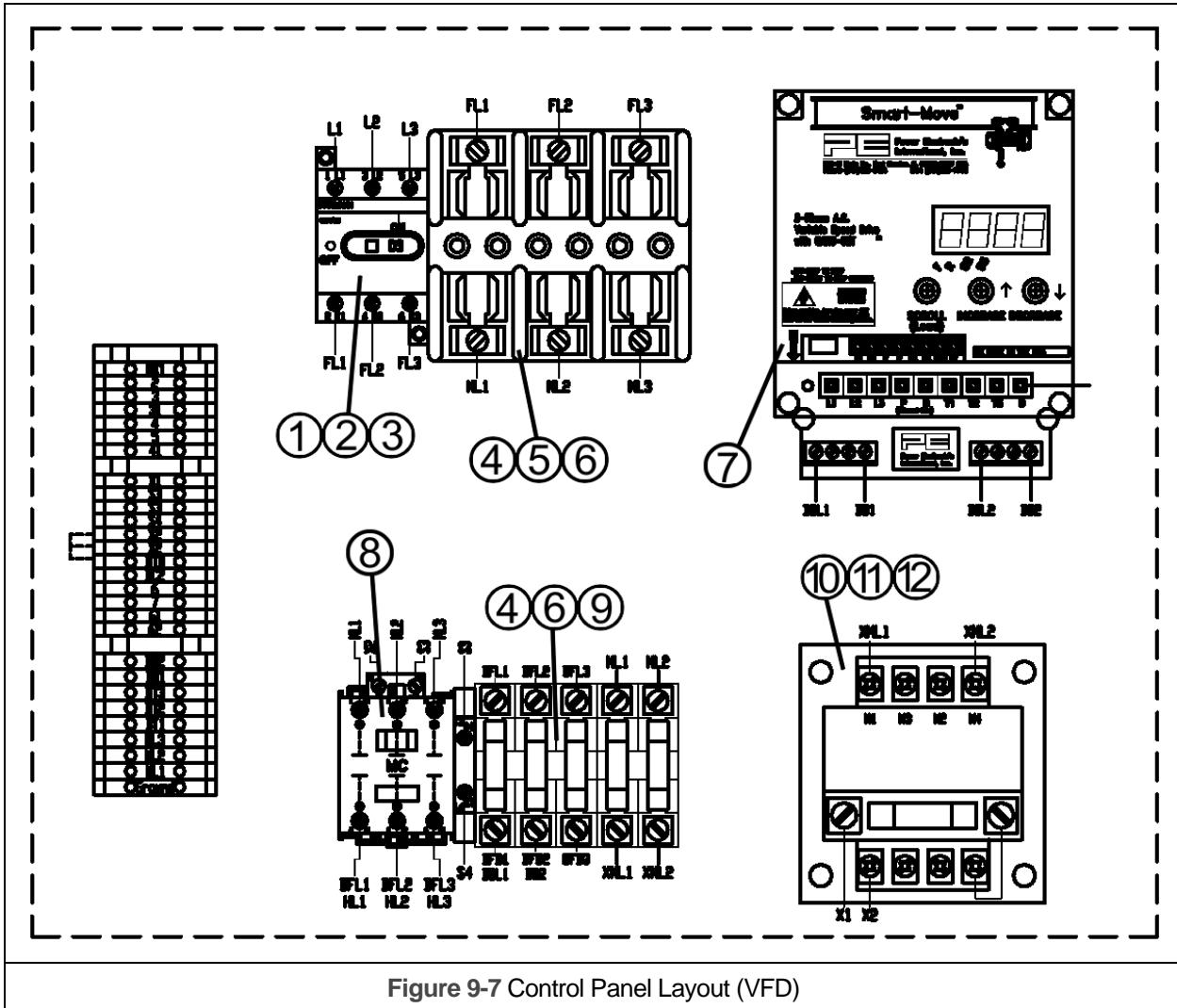
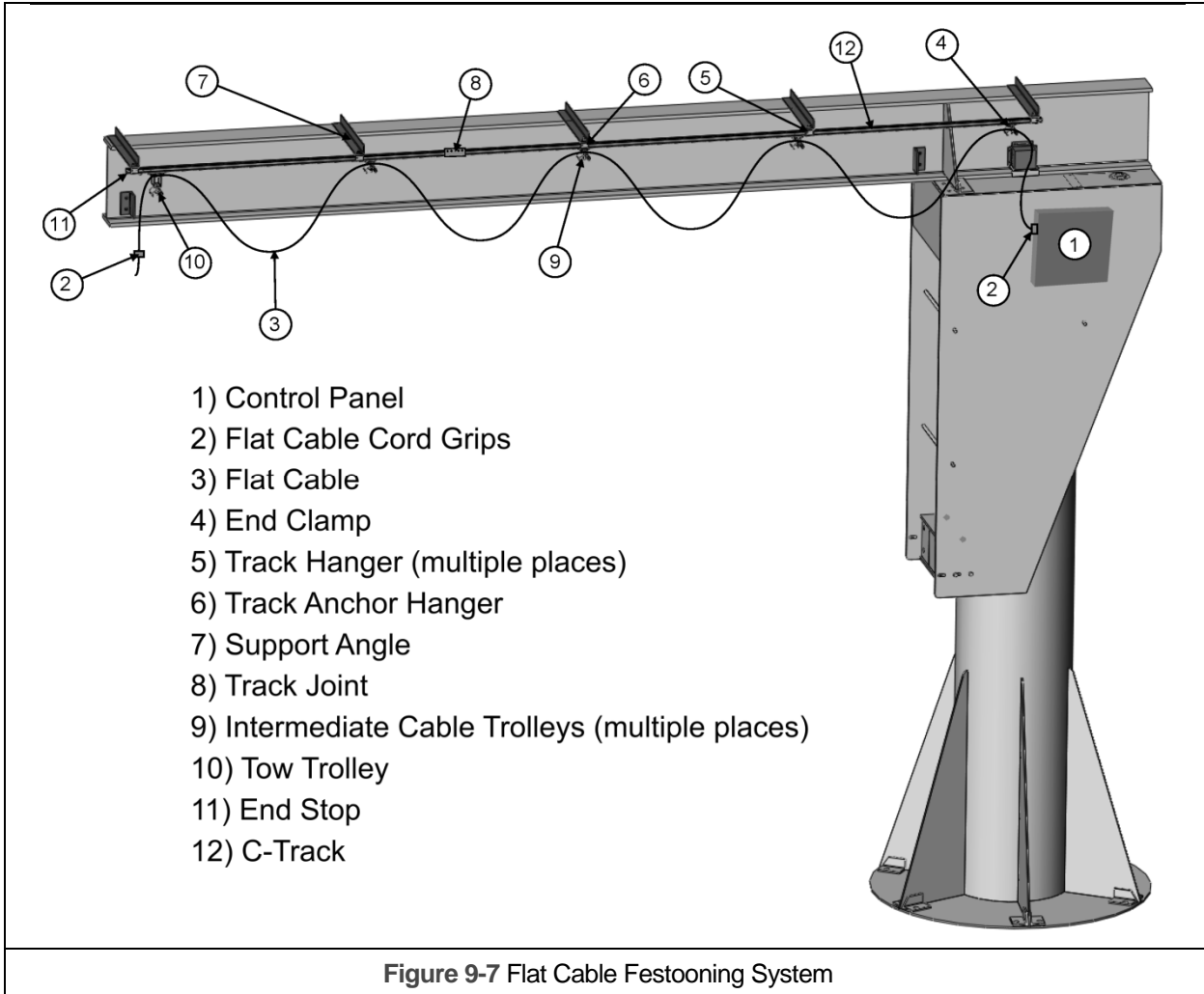

Figure 9-7 Control Panel Layout (VFD)

9.3 Control Panel

Figure No.	Description	Qty	Part Number
1	Selector Switch	1	TTCDH5S
2	30A Disconnect	1	TTCDNF32A3
3	Operating Shaft	1	TTBDS330S
4	Fuse Block, 30amp	2	TTBM6033PQ
5	Fuse, Midget Time Delay 30amp	3	TTFNQ 30
6	Din Rail Clip	4	TTDRA1
7	Inverter (4amp with brake relay)	1	TTMSM4ARP
8	Main line contactor, 30amp	1	TT100-C30D10
9	Fuse, Midget Time Delay 6amp	1	TTFNQ 6
10	Transformer, 200VA 460/230	1	TT1497-DBASX1N
11	Transformer Fuse, Time Delay	1	TTFNM 2.5
12	Surge Suppressor	1	TTRCS1A6

9.4 Flat Cable



9.4 Flat Cable

Figure No.	Part Name*		Part Number
1	Control Panel Enclosure	Single Speed	TTA16148CHFL
		VFD	TTC-SD24168
2	Flat Cable Cord Grips	For 4c/10awg	TT35835C
		For 8c/16awg	TT35837D
		For 4c/10awg and 8c/16awg	TT35837J
		For 12c/16awg	TT35838D
3	Flat Cable	4c/10awg	TT22542Y
		8c/16awg	TT22607Y
		2c/16awg	TT23324Y
4	End Clamp		TT21957
5	Track Hanger		TT28510
6	Track Anchor Hanger		TT28511
7	Track Support Angle (6" increments from 12" to 48")		TT4259980
8	Track Joint		TT023210
9	Cable Trolley		TT21991
10	Tow Trolley		TT22168
11	End stop		TT023215
12	C-track		TT534176

*The parts listed above are for standard applications. For parts for optional configuration, refer to Bill of Materials or contact Product Support.

9.5 Labels

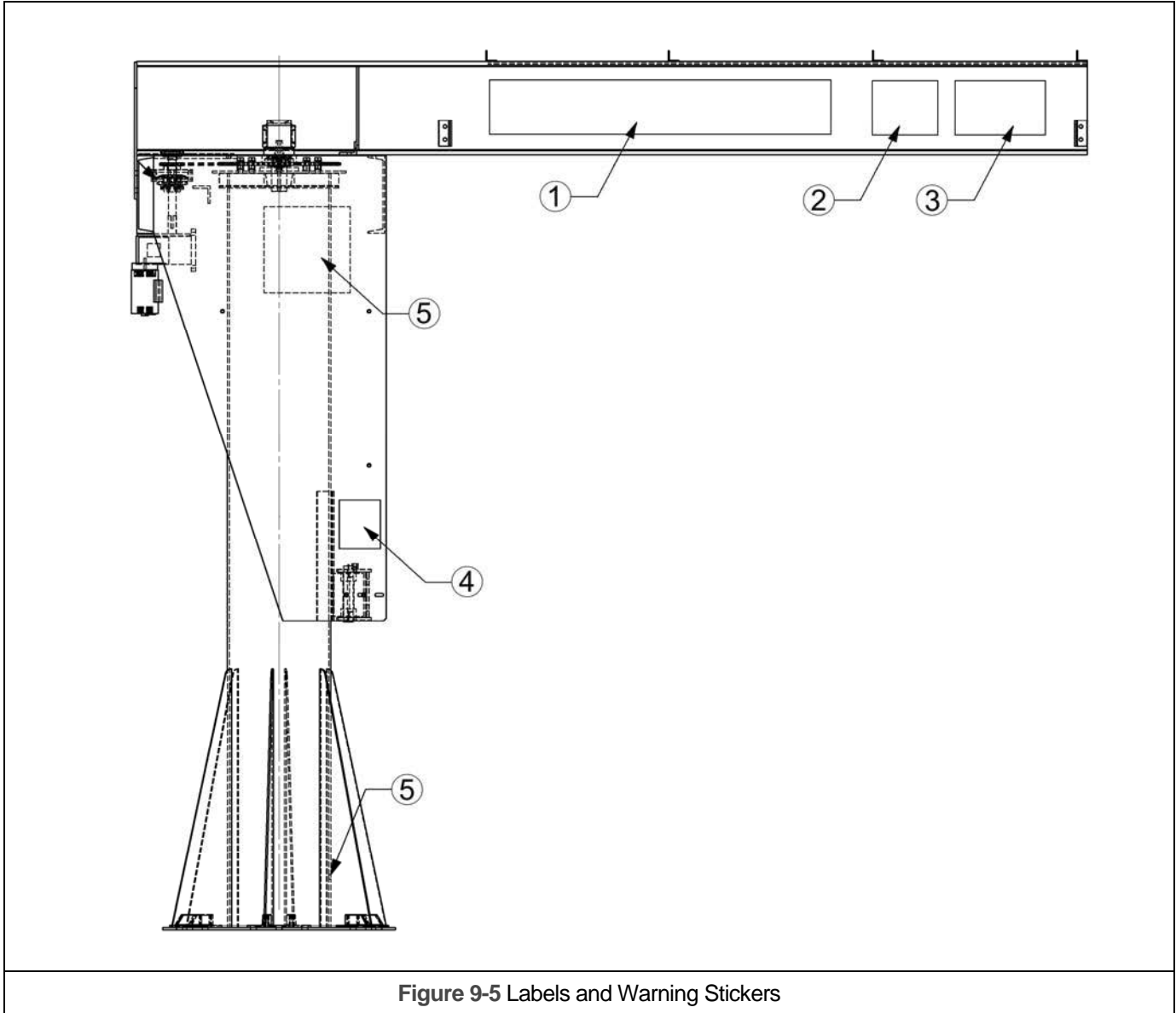

Figure 9-5 Labels and Warning Stickers

9.5 Labels

Figure No.	Description	Qty	BOOM HEIGHT (INCHES)							
			6	8	10	12	14	16	18	20
1	Logo	2	8047301				8047302			
2	Capacity Number, 1	-	8047306							
	Capacity Number, 2		8047307							
	Capacity Number, 3		8047308							
	Capacity Number, 4		8047309							
	Capacity Number, 5		8047310							
	Capacity Number, 6		8047311							
	Capacity Number, 7		8047312							
	Capacity Number, 8		8047313							
	Capacity Number, 9		8047314							
	Capacity Number, 0		8047315							
	Capacity Slash		8047316							
3	Capacity Unit, TON	2	8047303							
	Capacity Unit, LBS		8047304							
	Capacity Unit, KG		8047305							
4	Pinching Danger label	2	80472							
5	Voltage Danger Label	2	8047317							

This Page Intentionally Left Blank

This Page Intentionally Left Blank



Harrington Hoists, Inc.
401 West End Avenue
Manheim, PA 17545

www.harringtonhoists.com

Toll Free: 800-233-3010
Phone: 717-665-2000
Fax: 717-665-2861

TT351M-352M-OM-ENG